

bq2477x NVDC Battery Charge Controller With System Power Monitor and Processor Hot Indicator

1 Features

- Host-controlled NVDC-1 1S-4S Battery Charge Controller with 4.5-24 V Input Range
 - Support SMBus (bq24770) and I2C (bq24773)
 - System Instant-on Operation with no Battery or Deeply Discharged Battery
 - Supplement Mode with Synchronous BATFET Control when Adaptor is fully loaded
- Ultra Fast Input Current DPM at 100 μ s
- Ultra Low Quiescent Current of 600 μ A and High PFM Light Load Efficiency >80% at 20 mA Load to Meet Energy Star and ErP Lot6.
- High Accuracy Power / Current Monitor for CPU Throttling
 - Comprehensive PROCHOT Profile
 - Input and Battery Current Monitor (IADP/IBAT)
 - System Power Monitor (PMON)
- Programmable Input Current Limit, Charge Voltage, Charge Current and Minimum System Voltage Regulation
 - $\pm 0.5\%$ Charge Voltage (16 mV/step)
 - $\pm 2\%$ Input/charge Current (64 mA/step)
 - $\pm 2\%$ 40x Input / 16x Discharge / 20x Charge Current Monitor
- Support Battery LEARN Function
- High Integration
 - NMOS ACFET and RBFET Driver
 - PMOS battery FET Gate Driver
 - Internal Loop Compensation
 - Independent Comparator
 - Automatic Trickle Charge to Wake up Gas Gauge
- 600kHz to 1.2MHz Programmable Switching Frequency

2 Applications

- Ultrabook, Notebook, Detachable, and Tablet PC
- Handheld Terminal
- Industrial, Medical, Portable Equipment

3 Description

The bq2477x is high-efficiency, synchronous, NVDC-1 battery charge controllers, offering low component count for space-constraint, multi-chemistry battery charging applications.

The power path management allows the system to be regulated at battery voltage but does not drop below system minimum voltage (programmable). With this feature, the system keeps operating even when the battery is completely discharged or removed. The power path management allows the battery to provide supplement current to the system to keep the input supply from being overloaded.

The bq2477x provides drivers and power path management for N-channel ACFET and reverse blocking FET. The device provides driver to control NVDC operation of external P-channel battery FET. It also drives high-side and low-side MOSFETs of the switching regulator.

The bq2477x monitors adapter current (IADP), battery charge/discharge current (IBAT) and system power (PMON). The flexibly programmed PROCHOT output goes directly to CPU for throttle back when needed.

Device Information⁽¹⁾

PART NUMBER	PACKAGE	BODY SIZE (NOM)
bq24770	WQFN (28-Pin)	4.00mm x 4.00mm ²
bq24773		

(1) For all available packages, see the orderable addendum at the end of the data sheet.

Simplified Schematic

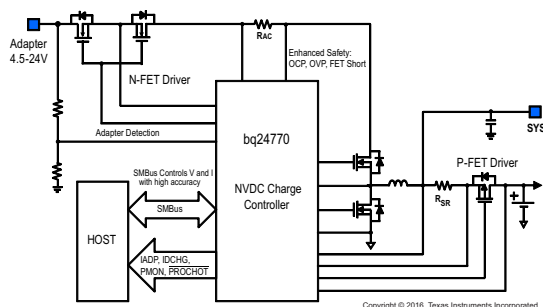

Light Load Efficiency ($V_{IN} = 19.5$ V)

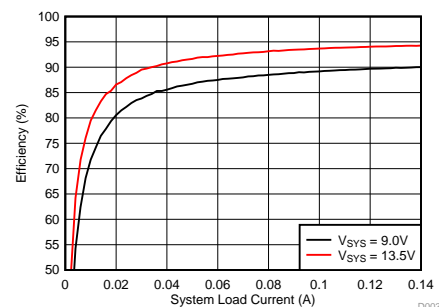

Table of Contents

1 Features	1	8.4 Device Functional Modes	21
2 Applications	1	8.5 Programming	21
3 Description	1	8.6 Register Maps	26
4 Revision History	2	9 Application and Implementation	36
5 Device Comparison Table	3	9.1 Application Information	36
6 Pin Configuration and Functions	3	9.2 Typical Application, bq24770	36
7 Specifications	5	10 Power Supply Recommendations	44
7.1 Absolute Maximum Ratings	5	11 Layout	44
7.2 ESD Ratings	5	11.1 Layout Guidelines	44
7.3 Recommended Operating Conditions	6	11.2 Layout Example	45
7.4 Thermal Information	6	12 Device and Documentation Support	46
7.5 Electrical Characteristics	6	12.1 Related Links	46
7.6 Timing Requirements	12	12.2 Receiving Notification of Documentation Updates	46
7.7 Typical Characteristics	13	12.3 Community Resources	46
8 Detailed Description	14	12.4 Trademarks	46
8.1 Overview	14	12.5 Electrostatic Discharge Caution	46
8.2 Functional Block Diagram	15	12.6 Glossary	46
8.3 Feature Description	16	13 Mechanical, Packaging, and Orderable Information	46

4 Revision History

Changes from Revision B (October 2014) to Revision C

Page

- | | |
|---|---|
| • First public release of the full data sheet | 1 |
|---|---|

Changes from Revision A (October 2014) to Revision B

Page

- | | |
|--|----|
| • Changed text in the Simplified Schematic From; "Hybrid Power Boost Charge" To NVDC Charge" | 1 |
| • Changed Equation 1 From: "V = K _(PMON) ..." To: "I = K _(PMON) ..." | 17 |
| • Changed 0x2011H to 0x0211H in the POS STATE column of Table 4 | 26 |
| • Changed 0x4854H to 0x4B54H in the POS STATE column of Table 4 | 26 |
| • Changed Table 7 , column "SMBus 0x3CH" To: "SMBus 0x38H" | 29 |

Changes from Original (August 2014) to Revision A

Page

- | | |
|--|----|
| • Changed the equation in the description of pin 21 From: $V_{(ILIM)} = 20 \times IDPM \times (V_{(ACP)} - V_{(ACN)})$ To: $V_{(ILIM)} = 20 \times IDPM \times R_{AC}$ | 4 |
| • Changed the t_f MAX value From 300 μ s To: 300 ns | 12 |
| • Added a new first paragraph to the Learn Mode section | 19 |
| • Added a NOTE to the Application and Implementation section | 36 |
| • Changed Figure 21 | 36 |
| • Changed Figure 36 | 43 |

5 Device Comparison Table

	bq24770	bq24773
Communication Interface	SMBus	I2C
Communication Address	0x12H (0x00010010)	D4H (0x11010100)
Default Switching Frequency	800kHz	1.2MHz
Default Input Current Limit	3200mA	2944mA
Device ID	0x0114H	0x41H

6 Pin Configuration and Functions

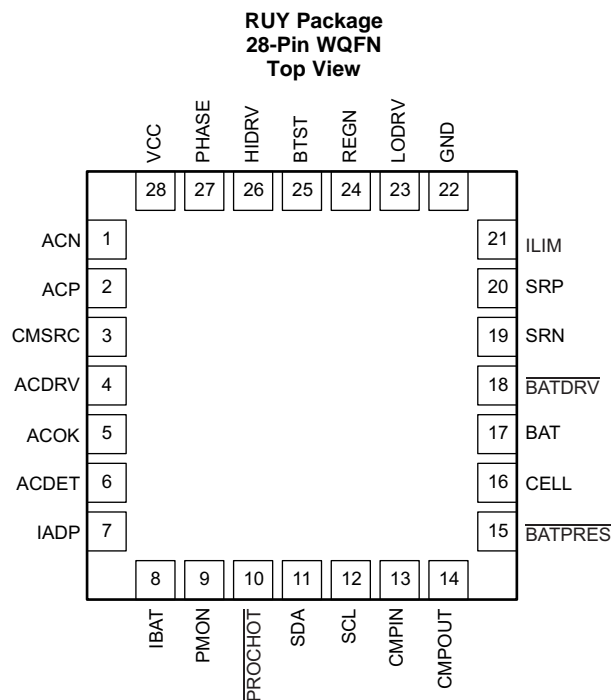

Pin Functions

PIN	NAME	DESCRIPTION
1	ACN	Input current sense resistor negative input. Place an optional 0.1- μ F ceramic capacitor from ACN to GND for common-mode filtering. Place a 0.1- μ F ceramic capacitor from ACN to ACP to provide differential mode filtering.
2	ACP	Input current sense resistor positive input. Place a 1- μ F and 0.1- μ F ceramic capacitor from ACP to GND for common-mode filtering. Place a 0.1- μ F ceramic capacitor from ACN to ACP to provide differential-mode filtering.
3	CMSRC	ACDRV charge pump source input. Place a 4 k Ω resistor from CMSRC to the common source of ACFET (Q1) and RBFET (Q2) limits the in-rush current on CMSRC pin. When CMSRC is grounded, ACDRV pin becomes logic output internally pulled up to REGN. ACDRV HIGH indicates to external driver that ACFET/RBFET can be turned on. It directly drives CMOS logic.
4	ACDRV	Charge pump output to drive both adapter input n-channel MOSFET (ACFET) and reverse blocking n-channel MOSFET (RBFET). ACDRV voltage is 6 V above CMSRC to turn on ACFET/RBFET when ACOK goes HIGH. Place a 4 k Ω resistor from ACDRV to the gate of ACFET and RBFET limits the in-rush current on ACDRV pin. When CMSRC is grounded, ACDRV pin becomes logic output internally pulled up to REGN. ACDRV HIGH indicates that ACFET/RBFET can be turned on. It directly drives CMOS logic.
5	ACOK	Active HIGH AC adapter detection open drain output. It is pulled HIGH to external pull-up supply rail by external pull-up resistor when a valid adapter is present (ACDET above 2.4 V, VCC above UVLO but below ACOV and VCC above BAT). If any of the above conditions is not valid, ACOK is pulled LOW by internal MOSFET. Connect a 10-k Ω pull up resistor from ACOK to the pull-up supply rail.

Pin Functions (continued)

PIN	NAME	DESCRIPTION
6	ACDET	Adapter detection input. Program adapter valid input threshold by connecting a resistor divider from adapter input to ACDET pin to GND pin. When ACDET pin is above 0.6 V and VCC is above UVLO, REGN LDO is present, ACOK comparator, and input current monitor buffer (IADP) are all active. Independent comparator, IBAT buffer, PMON buffer and $\overline{\text{PROCHOT}}$ can be enabled with SMBus/I2C. When ACDET pin is above 2.4 V, and VCC is above BAT, but below ACOV, ACOK goes HIGH. ACFET/RBFET turns on.
7	IADP	Buffered adapter current output. $V_{(IADP)} = 40 \text{ or } 80 \times (V_{(ACP)} - V_{(ACN)})$ The ratio of 40x and 80x is selectable with SMBus/I2C. Place 100pF or less ceramic decoupling capacitor from IADP pin to GND. This pin can be floating if it is not in use. IADP output voltage is clamped below 3.3 V.
8	IBAT	Buffered battery current selected by SMBus/I2C. $V_{(IBAT)} = 20 \times (V_{(SRP)} - V_{(SRN)})$ for charge current, or $V_{(IBAT)} = 8 \text{ or } 16 \times (V_{(SRN)} - V_{(SRP)})$ for discharge current, with ratio selectable through SMBus/I2C. Place 100pF or less ceramic decoupling capacitor from IBAT pin to GND. This pin can be floating if not in use. Its output voltage is clamped below 3.3 V.
9	PMON	Current mode system power monitor. The output voltage is proportional to the total power from the adapter and battery. The gain is selectable through SMBus/I2C. This pin can be floating if not in use. Its output voltage is clamped below 3.3 V. The maximum cap on PMON is 100 pF.
10	$\overline{\text{PROCHOT}}$	Active low open drain output of "processor hot" indicator. It monitors adapter input current, battery discharge current, and system voltage. After any event in the PROCHOT profile is triggered, a minimum 10-ms pulse is asserted.
11	SDA	SMBus/I2C open-drain data I/O. Connect to data line from the host controller or smart battery. Connect a 10-k Ω pull-up resistor according to SMBus/I2C specifications.
12	SCL	SMBus/I2C clock input. Connect to clock line from the host controller or smart battery. Connect a 10-k Ω pull-up resistor according to SMBus/I2C specifications.
13	CMPIN	Input of independent comparator. Internal reference, output polarity and deglitch time is selectable by SMBus/I2C. With polarity HIGH (0x3B[6]=1), place a resistor between CMPIN and CMPOUT to program hysteresis. With polarity LOW (0x3B[6]=0), the internal hysteresis is 100 mV. If the independent comparator is not in use, tie CMPIN to ground.
14	CMPOUT	Open-drain output of independent comparator. Place 10k Ω pull-up resistor from CMPOUT to pull-up supply rail. Internal reference, output polarity and deglitch time are selectable by SMBus/I2C.
15	$\overline{\text{BATPRES}}$	Active low battery present input signal. LOW indicates battery present, HIGH indicates battery absent. When $\overline{\text{BATPRES}}$ pin goes from LOW to HIGH, the device exits LEARN mode, and disable charge. REG 0x15() value goes back to default. Host can enable IDPM and charge through SMBus/I2C when $\overline{\text{BATPRES}}$ is HIGH.
16	CELL	Battery cell selection pin. GND for 1-cell, Float for 2-cell, and HIGH for 3- or 4-cell. CELL pin is biased from REGN. Before host writes to MaxChargeVoltage(), MaxChargeVotage() follows the CELL pin setting. CELL pin also sets SYSOVP threshold. GND for 5 V, Float for 12 V and HIGH for 18.5 V. When REG 0x15() is above 15V, SYSOVP is disabled.
17	BAT	Battery-voltage remote sense. Directly connect a Kelvin sense trace from the battery-pack positive terminal to the BAT pin to accurately sense the battery pack voltage. Place a 0.1- μ F capacitor from BAT to GND close to the IC to filter high-frequency noise.
18	$\overline{\text{BATDRV}}$	P-channel battery FET (BATFET) gate driver output. It is shorted to SRN to turn off the BATFET. It goes below SRN to turn on BATFET. BATFET is in linear mode to regulate SYS at minimum system voltage when battery is depleted. BATFET is fully on during fast charge and supplement mode. Connect the source of the BATFET to charge current sensing node SRN pin, and the drain of the BATFET to the battery pack positive node BAT pin.
19	SRN	Charge current sense resistor negative input. SRN pin is for battery voltage sensing as well. Connect SRN pin with a 0.1 μ F ceramic capacitor to GND for common-mode filtering. Connect a 0.1- μ F ceramic capacitor from SRP to SRN to provide differential mode filtering.
20	SRP	Charge current sense resistor positive input. Connect a 0.1- μ F ceramic capacitor from SRP to SRN to provide differential mode filtering.
21	ILIM	Input current limit input. Program ILIM voltage by connecting a resistor divider from supply rail to ILIM pin to GND pin. The ILIM voltage is calculated as: $V_{(ILIM)} = 20 \times \text{IDPM} \times R_{AC}$, in which IDPM is the target regulation current. The lower of ILIM voltage and DAC limit voltage sets input current regulation limit. Host can ignore the IDPM setting from ILIM pin by setting 0x38[7]=0.
22	GND	IC ground. On PCB layout, connect to analog ground plane, and only connect to power ground plane through the power pad underneath IC.
23	LODRV	Low side power MOSFET driver output. Connect to low side n-channel MOSFET gate.
24	REGN	5.4V linear regulator output supplied from VCC. The LDO is active when ACDET above 0.6V, VCC above UVLO. Connect a 1 μ F ceramic capacitor from REGN to power ground.

Pin Functions (continued)

PIN	NAME	DESCRIPTION
25	BTST	High side power MOSFET driver power supply. Connect a 0.047- μ F capacitor from BTST to PHASE. The bootstrap diode between REGN and BTST is integrated.
26	HIDRV	High side power MOSFET driver output. Connect to the high side n-channel MOSFET gate.
27	PHASE	High side power MOSFET driver source. Connect to the source of the high side n-channel MOSFET.
28	VCC	Input supply from adapter or battery. Place Schottky diode-OR from adapter/battery. After the Schottky diode, place 10- Ω resistor and 1- μ F capacitor to ground as low pass filter to limit inrush current.
	Thermal Pad	Exposed pad beneath the IC. Analog ground and power ground star-connected only at the thermal pad plane. Always solder thermal pad to the board, and have vias on the thermal pad plane connecting to analog ground and power ground planes. It also serves as a thermal pad to dissipate the heat.

7 Specifications

7.1 Absolute Maximum Ratings

over operating free-air temperature range (unless otherwise noted) ⁽¹⁾⁽²⁾

		MIN	MAX	UNIT
Voltage range	SRN, SRP, ACN, ACP, CMSRC, VCC, BAT, $\overline{\text{BATDRV}}$	-0.3	30	V
	PHASE	-2.0	30	V
	BTST, HIDRV, ACDRV	-0.3	36	V
	LODRV (2% duty cycle)	-4.0	7	V
	HIDRV (2% duty cycle)	-4.0	36	V
	PHASE (2% duty cycle)	-4.0	30	V
	ACDET, SDA, SCL, LODRV, REGN, IADP, IBAT, PMON, $\overline{\text{BATPRES}}$, ACOK, CELL, CMPIN, CMPOUT, ILIM	-0.3	7	V
	$\overline{\text{PROCHOT}}$	-0.3	5.5	V
Differential voltage	BTST-PHASE, HIDRV-PHASE	-0.3	7	V
	SRP-SRN, ACP-ACN	-0.5	0.5	V
Junction temperature range, T_J		-40	155	$^{\circ}\text{C}$
Storage temperature range, T_{stg}		-55	155	$^{\circ}\text{C}$

- (1) Stresses beyond those listed under *Absolute Maximum Ratings* may cause permanent damage to the device. These are stress ratings only, which do not imply functional operation of the device at these or any other conditions beyond those indicated under *Recommended Operating Conditions*. Exposure to absolute-maximum-rated conditions for extended periods may affect device reliability.
- (2) All voltages are with respect to GND if not specified. Currents are positive into, negative out of the specified terminal. Consult Packaging Section of the data book for thermal limitations and considerations of packages.

7.2 ESD Ratings

		MIN	MAX	UNIT	
$V_{\text{(ESD)}}$	Electrostatic discharge	Human body model (HBM), per ANSI/ESDA/JEDEC JS-001, all pins ⁽¹⁾	0	2	kV
		Charged device model (CDM), per JEDEC specification JESD22-C101, all pins ⁽²⁾	0	500	V

- (1) JEDEC document JEP155 states that 500-V HBM allows safe manufacturing with a standard ESD control process.
- (2) JEDEC document JEP157 states that 250-V CDM allows safe manufacturing with a standard ESD control process.

7.3 Recommended Operating Conditions

over operating free-air temperature range (unless otherwise noted)

		MIN	MAX	UNIT
Voltage range	ACN, ACP, CMSRC, VCC	0	24	V
	BATDRV, BAT, SRN, SRP	0	19.2	V
	PHASE	-2	24	V
	BTST, HIDRV, ACDRV	0	30	V
	ACDET, SDA, SCL, LODRV, REGN, IADP, IBAT, PMON, BATPRES, ACOK, CELL, CMPIN, CMPOUT, ILIM	0	6.5	V
	PROCHOT	-0.3	5.3	V
Differential voltage	BTST-PHASE, HIDRV-PHASE	0	6.5	V
	SRP-SRN, ACP-ACN	-0.35	0.35	V
Junction temperature range, T _J		-20	125	°C
Operating free-air temperature range, T _A		-40	85	°C

7.4 Thermal Information

THERMAL METRIC ⁽¹⁾		bq2477x	UNIT
		RUY (WQFN)	
		28 PINS	
R _{θJA}	Junction-to-ambient thermal resistance	33.3	°C/W
R _{θJC(top)}	Junction-to-case (top) thermal resistance	29.7	°C/W
R _{θJB}	Junction-to-board thermal resistance	6.5	°C/W
Ψ _{JT}	Junction-to-top characterization parameter	0.3	°C/W
Ψ _{JB}	Junction-to-board characterization parameter	6.5	°C/W
R _{θJC(bot)}	Junction-to-case (bottom) thermal resistance	1.3	°C/W

(1) For more information about traditional and new thermal metrics, see the [Semiconductor and IC Package Thermal Metrics](#) application report.

7.5 Electrical Characteristics

 $4.5V \leq V_{(VCC)} \leq 24V$, $-20^{\circ}C \leq T_J \leq 125^{\circ}C$, typical values are at T_A = 25°C, with respect to GND (unless otherwise noted)

PARAMETER	TEST CONDITION	MIN	TYP	MAX	UNIT
OPERATING CONDITIONS					
V _(IN_OP)	Input voltage operating range	4.5		24	V
MINIMUM SYSTEM VOLTAGE REGULATION (0x3E REGISTER)					
V _(SYSMIN_RNG)	System voltage regulation range	1.024		19.2	V
V _(MINSYS_REG_ACC)	Minimum system voltage regulation accuracy	MinsystemVoltage()=0x2400H	9.216		V
		MinsystemVoltage()=0x1800H	-2%	2%	
		MinsystemVoltage()=0x0E00H	-3%	3%	
MAXIMUM SYSTEM VOLTAGE REGULATION (0x15 REGISTER, CHARGE DISABLE)					
V _(SYSMAX_RNG)	System voltage regulation range	1.024		19.2	V
V _(MAXSYS_REG_ACC)	Maximum system voltage regulation accuracy	MaxChargVoltage() = 0x34C0H	13.504		V
		MaxChargVoltage() = 0x2330H	-2%	2%	
		MaxChargVoltage() = 0x1130H	-3%	3%	

Electrical Characteristics (continued)

4.5V ≤ V_(VCC) ≤ 24V, −20°C ≤ T_J ≤ 125°C, typical values are at T_A = 25°C, with respect to GND (unless otherwise noted)

PARAMETER		TEST CONDITION	MIN	TYP	MAX	UNIT
CHARGE VOLTAGE REGULATION (0x15 REGISTER, CHARGE ENABLE)						
V _(BAT_RGN)	Battery voltage range		1.024		19.2	V
V _(BAT_REG_ACC)	Battery voltage regulation accuracy (0°C - 85°C)	ChargeVoltage() = 0x41A0H		16.8		V
			−0.5%		0.5%	
		ChargeVoltage() = 0x3130H		12.592		V
			−0.5%		0.5%	
		ChargeVoltage() = 0x20D0H		8.4		V
		−0.6%		0.6%		
		ChargeVoltage() = 0x1070H		4.208		V
			−1%		1%	
CHARGE CURRENT REGULATION						
V _(IREG_CHG_RNG)	Charge current regulation differential voltage range	V _(IREG_CHG) = V _(SRP) − V _(SRN)	0		81.28	mV
I _(CHRG_REG_ACC)	Charge current regulation accuracy 10 Ω current sensing resistor, V _{BAT} > V _(SYSMIN) (0°C - 85°C)	ChargeCurrent() = 0x1000H		4096		mA
			−2%		2%	
		ChargeCurrent() = 0x0800H		2048		mA
			−4%		3%	
		ChargeCurrent() = 0x0400H		1024		mA
		−6%		5%		
		ChargeCurrent() = 0x0200H		512		mA
			−12%		10%	
I _(CLAMP)	Pre-charge current clamp (2s-4s)	CELL = Float or High, BAT below 0x3E(), in LDO mode		384		mA
	Pre-charge current clamp (1s only)	CELL = LOW, BAT below BATLOWV threshold		384		mA
	Fast charge current clamp (1s only)	CELL = LOW, BAT above BATLOWV threshold, but below 0x3E()		2		A
PRECHARGE CURRENT REGULATION IN LDO MODE						
I _(PRECHRG_REG_ACC)	Precharge current regulation accuracy, V _{BAT} > V _(SYSMIN) (0°C - 85°C)	ChargeCurrent() = 0x0180H		384		mA
			−15%		15%	
		ChargeCurrent() = 0x0100H		256		mA
			−20%		20%	
		ChargeCurrent() = 0x00C0H		192		mA
		−25%		25%		
		ChargeCurrent() = 0x0080H		128		mA
			−30%		30%	
I _(LEAK_SRP_SRN)	SRP, SRN leakage current mismatch		−21		21	μA
LDO MODE TO FAST CHARGE COMPARATOR						
V _(BAT_SYSMIN)	LDO mode to fast charge mode threshold, V _{BAT} rising	as percentage of 0x3E()	94%	96%	99%	
V _(BAT_SYSMIN_HYST)	Fast charge mode to LDO mode threshold hysteresis	as percentage of 0x3E()		4%		
INPUT CURRENT REGULATION						
V _(IREG_DPM_RNG)	Input current regulation differential voltage range	V _(IREG_DPM) = V _(ACP) − V _(ACN)	0		81.28	mV
I _(DPM_REG_ACC)	Input current regulation accuracy	ChargeCurrent() = 0x1000H		4096		mA
			−2		2%	
		ChargeCurrent() = 0x0800H		2048		mA
			−3		3%	
		ChargeCurrent() = 0x0400H		1024		mA
		−5		5%		
		ChargeCurrent() = 0x0200H		512		mA
			−10		10%	

Electrical Characteristics (continued)

4.5V ≤ V_(VCC) ≤ 24V, -20°C ≤ T_J ≤ 125°C, typical values are at T_A = 25°C, with respect to GND (unless otherwise noted)

PARAMETER		TEST CONDITION	MIN	TYP	MAX	UNIT
I _(LEAK_ACP_ACN)	ACP, ACN leakage current mismatch		-11		20	μA
INPUT CURRENT SENSE AMPLIFIER						
V _(ACP/N_OP)	Input common mode range	Voltage on ACP/ACN	4.5		24	V
V _(IADP_CLAMP)	IADP output clamp voltage		3.1	3.2	3.3	V
I _(IADP)	IADP output current				1	mA
A _(IADP)	Input current sense gain	V _{(IADP)/V_(ACP-ACN)} , ChargeOption0[4]=0, (770/773)		40		V/V
		V _{(IADP)/V_(ACP-ACN)} , ChargeOption0[4]=1, (770/773)		80		
V _(IADP_ACC)	Input current monitor accuracy	V _(ACP-ACN) = 40.96 mV	-2%		2%	
		V _(ACP-ACN) = 20.48 mV	-3%		4%	
		V _(ACP-ACN) = 10.24 mV	-6%		7%	
		V _(ACP-ACN) = 5.12 mV	-10%		18%	
C _(IADP_MAX)	Maximum output load capacitance				100	pF
CHARGE CURRENT AND DISCHARGE CURRENT SENSE AMPLIFIER						
V _(SRP/N_OP)	Battery common mode range	Voltage on SRP/SRN	2.8		18	V
V _(IBAT_CLAMP)	IBAT output clamp voltage		3.1	3.2	3.3	V
I _(IBAT)	IBAT output current				1	mA
A _(IBAT_DCHG)	Discharge current sensing gain on IBAT pin	V _{(IBAT)/V_(SRN-SRP)} , ChargeOption0[3]=0		8		V/V
		V _{(IBAT)/V_(SRN-SRP)} , ChargeOption0[3]=1		16		
I _(IBAT_DCHG_ACC)	Discharge current monitor accuracy on IBAT pin	V _(SRN-SRP) = 40.96 mV	-2%		2%	
		V _(SRN-SRP) = 20.48 mV	-3%		3%	
		V _(SRN-SRP) = 10.24 mV	-5%		5%	
		V _(SRN-SRP) = 5.12 mV	-10%		10%	
A _(IBAT_CHG)	Charge current sensing gain on IBAT pin	V _{(IBAT)/V_(SRN-SRP)}		20		V/V
I _(IBAT_CHG_ACC)	Charge current monitor accuracy on IBAT pin (0°C - 85°C)	V _(SRN-SRP) = 40.96 mV	-2%		2%	
		V _(SRN-SRP) = 20.48 mV	-3%		4%	
		V _(SRN-SRP) = 10.24 mV	-5%		7%	
		V _(SRN-SRP) = 5.12 mV	-10%		15%	
C _(IBAT_MAX)	Maximum output load capacitance				100	pF
SYSTEM POWER SENSE AMPLIFIER						
V _(ACP/N_OP)	Input common mode range	Voltage on ACP/ACN	4.5		24	V
V _(SRP/N_OP)	Battery common mode range	Voltage on SRP/SRN	2.8		18	V
V _(PMON)	Power buffer output voltage				3.3	V
V _(PMON_CLAMP)	Power buffer clamp voltage		3	3.2	3.3	V
I _(PMON)	Power buffer output current				105	μA
A _(PMON)	System power sense gain, V _{(PMON)/(V_(ACP-ACN) × V_(ACN) + V_(SRN-SRP) × V_(SRP))}	ChargeOption1[9]=0		0.25		μA/V
		ChargeOption1[9]=1		1		μA/V
V _(PMON_ACC)	PMON output accuracy	Input 19.5 V, 65W, 1 μA/W	-5%		5%	
		Battery 11 V, 44W, 1 μA/W	-6%		6%	
REGN REGULATOR						
V _(REGN_REG)	REGN Regulator voltage (0 mA - 40 mA)	V _(VCC) > 10 V, V _(ACDET) > 0.6 V (0 - 50 mA load)	5	5.5	6	V
V _(DROPOUT)	REGN Voltage in drop out mode	V _(VCC) = 5 V, I _(LOAD) = 20 mA	4.4	4.6	4.7	V
I _(REGN_LIM)	REGN Current Limit when converter is disabled or in T _(SHUT) (no charging)	V _(REGN) = 4 V, V _(ACP) > V _(UVLO) , 0.6 V < ACDET < 2.4 V	6.5			mA
	REGN Current Limit when converter is enabled (charging)	V _(REGN) = 4 V, V _(ACP) > V _(UVLO)	50	65		mA
C _(REGN)	REGN Output Capacitor Required for Stability	I _(LOAD) = 100 μA to 50 mA		1		μF
QUIESCENT CURRENT						
I _(BAT_BATFET_OFF)	Standby mode. System powered by battery. BATFET off (0°C - 85°C). I _(SRN) + I _(SRN) + I _(SRP) + I _(PHASE) + I _(BTST) + I _(ACP) + I _(ACN) + I _(BAT) + I _(CMSRC) + I _(VCC)	V _(BAT) = 16.8 V V _(VCC) < V _(UVLO) , ACDET < 0.6 V		20	27	μA

Electrical Characteristics (continued)

4.5V ≤ V_(VCC) ≤ 24V, -20°C ≤ T_J ≤ 125°C, typical values are at T_A = 25°C, with respect to GND (unless otherwise noted)

PARAMETER		TEST CONDITION	MIN	TYP	MAX	UNIT
I _(BAT_BATFET_ON)	Standby mode. System powered by battery. BATFET on (0°C - 85°C). I _(SRN) + I _(SRP) + I _(PHASE) + I _(BTST) + I _(ACP) + I _(ACN) + I _{BAT} + I _(CMSRC) + I _(VCC)	V _{BAT} = 16.8 V V _(VCC) > V _(UVLO) , ACDET < 0.6 V, 0x12[15]=1, low power mode enabled		22	30	μA
		V _{BAT} = 16.8 V V _(VCC) > V _(UVLO) , ACDET < 0.6 V, 0x12[15]=0, 0x3B[2]=0, I _{BAT} Enabled, REGN = 0		114	150	μA
		V _{BAT} = 16.8 V V _(VCC) > V _(UVLO) , ACDET < 0.6 V, 0x12[15]=0, 0x3B[2]=0, I _{BAT} enabled, REGN = 5.5V		650	775	μA
I _(STANDBY)	Adapter standby quiescent current, I _(VCC) + I _(ACP) + I _(ACN) + I _(CMSRC) + I _(SRP) + I _(SRN) + I _(PHASE) + I _(BTST)	ACN = ACP = CMSRC = VCC = 20 V, V _{BAT} = 12.6V, V _(ACDET) > 2.4V, CELL pul up, T _J = 0°C - 85°C		650	815	μA
I _(AC_SWLIGHT)	Adapter current, I _(VCC) + I _(ACP) + I _(ACN) + I _(CMSRC) + I _(SRP) + I _(SRN) + I _(PHASE) + I _(BTST)	I _(STANDBY) plus supply current in PFM, 200mW output; Reg0x12[10]=0; MOSFET Qg=4 nF;		1.5	2	mA
		I _(STANDBY) plus supply current in PFM, 200mW output, Reg0x12[10]=1; limit 40kHz, MOSFET Qg=4 nF;		3	5	mA
I _(AC_SW)	Adapter current, I _(VCC) + I _(ACP) + I _(ACN) + I _(CMSRC) + I _(SRP) + I _(SRN) + I _(PHASE) + I _(BTST)	V _(UVLO) < V _(VCC) < V _(ACOVp) , V _{BAT} = 16.8 V, V _(ACDET) > 2.4 V, charge enabled, 800k Hz switching, MOSFET Qg=4 nF		8		mA
ACOK COMPARATOR						
V _(ACOK_RISE)	ACOK rising threshold	V _(VCC) > V _(UVLO) , ACDET rising	2.37	2.4	2.43	V
V _(ACOK_FALL)	ACOK falling threshold	V _(VCC) > V _(UVLO)	2.32	2.35	2.38	V
V _(ACOK_RISE_DEG)	ACOK rising deglitch to turn on ACFET	V _(VCC) > V _(UVLO)		2		ms
V _(ACOK_FALL_DEG)	ACOK falling deglitch to turn off ACFET	V _(VCC) > V _(UVLO)		2		μs
V _(WAKEUP_RISE)	WAKEUP detect rising threshold	ACDET rising		0.56	0.8	V
V _(WAKEUP_FALL)	WAKEUP detect falling threshold		0.3	0.5		V
UNDER VOLTAGE LOCKOUT COMPARATOR (UVLO)						
V _(UVLOZ)	V _{CC} undervoltage rising threshold	V _{CC} rising	2.5	2.7	2.9	V
V _(UVLO)	V _{CC} undervoltage falling threshold	V _{CC} falling	2.3	2.5	2.7	V
SLEEP COMPARATOR (VCC_BAT)						
V _(VCC_BAT_FALL)	VCC-BAT falling threshold	Input connected to VCC via schottky diode	-25	55	135	mV
V _(VCC_BAT_RISE)	VCC-BAT rising threshold		174	275	370	mV
t _{VCC_BAT_RDEG}	V _{CC} to BAT rising deglitch	V _{CC} rising above SRN deglitch to turn on ACDRV		4		ms
t _{VCC_SRN_FDEG}	V _{CC} to BAT falling deglitch	V _{CC} falls below SRN deglitch to turn off ACDRV		100		μs
INPUT OVERVOLTAGE COMPARATOR (ACOVp)						
V _(ACOV_RISE)	V _{CC} overvoltage rising threshold	V _{CC} rising	24	26	28	V
V _(ACOV_FALL)	V _{CC} overvoltage falling threshold	V _{CC} falling	22	24.5	27.5	V
V _(ACOV_RISE_DEG)	V _{CC} overvoltage rising deglitch	V _{CC} rising to turn off ACDRV		100		μs
V _(ACOV_FALL_DEG)	V _{CC} overvoltage falling deglitch	V _{CC} falling falling to turn on ACDRV		3		ms
INPUT OVERCURRENT COMPARATOR (ACOC)						
V _(ACOC)	ACP to ACN rising threshold, respect to inputcurrent(), peak	Voltage across input sense resistor rising, Reg0x12[7]=1	270%	300%	330%	
V _(ACOC_FLOOR)	Measure between ACP and ACN	Set IDPM to min	44	50	55	mV
V _(ACOC_CEILING)	Measure between ACP and ACN	Set IDPM to max	174	180	185	mV
t _{RELAX}	Falling deglitch time	Relax Time, No Latchoff		300		ms
SYSTEM OVERVOLTAGE COMPARATOR (SYS_OVP)						
V _(SYSOVP_RISE)	System Overvoltage rising threshold to turn off ACFET	CELL = Low	4.9	5	5.2	V
		CELL = Float	11.9	12	12.3	V
		CELL = High	18.4	18.5	19	V

Electrical Characteristics (continued)

4.5V ≤ V_(VCC) ≤ 24V, -20°C ≤ T_J ≤ 125°C, typical values are at T_A = 25°C, with respect to GND (unless otherwise noted)

PARAMETER		TEST CONDITION	MIN	TYP	MAX	UNIT
V _(SYSOVP_FALL)	System Overvoltage falling threshold	CELL = Low	4.6	4.7	4.9	V
		CELL = Float	10.9	11.1	11.3	V
		CELL = High	17.4	17.7	17.9	V
I _{OVP}	Discharge current when the OVP stop switching was triggered	On SRP and SRN		19		mA
t _{SYSOVP}	Deglitch time to latch off ACFET			25		µs
BAT OVERVOLTAGE COMPARATOR (BAT_OVP)						
V _(OVP_RISE)	Overvoltage rising threshold as percentage of V _(BAT_REG)	BAT rising	101%	102%	103%	
V _(OVP_FALL)	Overvoltage falling threshold as percentage of V _(BAT_REG)	BAT falling	100%	101%	102%	
I _{OVP}	Discharge current during OVP	On SRP and SRN		19		mA
t _{OVP_RISE}	Overvoltage rising deglitch to turn off BATDRV to disable charge			20		ms
CONVERTER CYCLE-BY-CYCLE COMPARATOR (ILIM_HI)						
V _(OCP_limit)	Converter over current limit (PH-GND)	Reg0x12 [6]=1	249	290	333	mV
		Reg0x12 [6]=0	142	170	202	mV
V _(OCP_limit_SYSSHORT)	System Short or SRN < 2.5 V	Reg0x12 [6]=1	41	66	87	mV
		Reg0x12 [6]=0	7	31	53	mV
CONVERTER CYCLE-BY-CYCLE UNDER-CURRENT COMPARATOR (UCP)						
V _(UCP_FALL)	Charge Undercurrent falling threshold	PH voltage when LSFET is on	-2.8		0.4	mV
BATTERY LOWV COMPARATOR						
V _(BATLV_FALL)	BATLOWV falling threshold	CELL = Low	2.64	2.85	3.06	V
		CELL = Float or High	5.71	5.92	6.12	V
V _(BATLV_RHYST)	BATLOWV rising threshold	CELL = Low	2.89	3.10	3.31	V
		CELL = Float or High	5.96	6.17	6.37	V
LIGHT LOAD COMPARATOR (LIGHT_LOAD)						
V _(LL_FALL)	Light load falling threshold detected on ACP-ACN		0	0.5	1.1	mV
V _(LL_RISE)	Light load rising threshold detected on ACP-ACN		0.7	1.4	2.1	mV
THERMAL SHUTDOWN COMPARATOR						
T _(SHUT)	Thermal shutdown rising temperature	Temperature increasing		155		°C
T _(SHUT_HYS)	Thermal shutdown hysteresis, falling			20		°C
t _{SHUT_RDEG}	Thermal shutdown rising deglitch			100		µs
t _{SHUT_FHYS}	Thermal shutdown falling deglitch			10		ms
VSYS PROCHOT COMPARATOR						
V _(SYS_PRO)	V _(SYS) threshold falling threshold	Reg0x3C [7:6]=00		5.75		V
		Reg0x3C [7:6]=01	5.9	6	6.15	V
		Reg0x3C [7:6]=10		6.25		V
		Reg0x3C [7:6]=11		6.5		V
t _{SYS_PRO_RISE_DEG}	V _(SYS) Rising Deglitch for throttling			20		µs
ICRIT PROCHOT COMPARATOR						
V _(ICRIT_PRO)	IADP rising threshold for throttling above IDPM	Reg0x3C [15:11]=01001	145%	150%	155%	
INOM PROCHOT COMPARATOR						
V _(INOM_PRO)	INOM rising threshold as percentage of IDPM		106%	110%	114%	
IDCHG PROCHOT COMPARATOR						
V _(IDCHG_PRO)	IDCHG threshold for throttling for IDSCHG of 6 A	Reg0x3D [15:10]=001100		6144		mA
				98%		104%

Electrical Characteristics (continued)

4.5V ≤ V_(VCC) ≤ 24V, -20°C ≤ T_J ≤ 125°C, typical values are at T_A = 25°C, with respect to GND (unless otherwise noted)

PARAMETER		TEST CONDITION	MIN	TYP	MAX	UNIT
INDEPENDENT COMPARATOR						
V _(INDEP_CMP)	Independent comparator threshold	Reg0x3B [7]=1, CMPIN rising	1.17	1.2	1.23	V
		Reg0x3B [7]=0, CMPIN rising	2.27	2.3	2.33	V
V _(INDEP_CMP_HYS)	Independent comparator hysteresis	Reg0x3B [6]=0, CMPIN falling		100		mV
PWM OSCILLATOR						
F _{SW}	PWM Switching frequency	Reg0x12 [9:8]=00	510	600	690	kHz
		Reg0x12 [9:8]=01	680	800	920	
		Reg0x12 [9:8]=10	850	1000	1150	
		Reg0x12 [9:8]=11	1020	1200	1380	
BATFET GATE DRIVER (BATDRV)						
V _(BATDRV_ON)	Gate Drive Voltage on BATFET	V _(SRN) - V _(BATDRV) when BAT = 16 V	8.5	9.5	10.5	V
R _(BATDRV_ON)	Measured by sourcing 10 μA current to BATDRV		3	3.5	4	kΩ
R _(BATDRV_OFF)	Measured by sinking 100 μA current from BATDRV		1.5	2	2.5	kΩ
ACFET GATE DRIVER (ACDRV)						
I _(ACFET)	ACDRV charge pump current limit	V _(ACDRV) - V _(CMSRC) = 5 V	40	60		μA
V _(ACDRV_ON)	Gate drive voltage on ACFET	V _(ACDRV) - V _(CMSRC) when V _(VCC) > V _(UVLO)	5.5	6.2		V
R _(ACDRV_OFF)	ACDRV turn-off resistance	I = 30 μA	5	6.2	7.4	kΩ
R _(ACDRV_LOAD)	Minimum load between gate and source		500			kΩ
PWM HIGH SIDE DRIVER (HIDRV)						
R _{DS(HI_ON)}	High side driver(HSD) turn-on resistance	V _(BTST) - V _(PH) = 5 V		4		Ω
R _{DS(HI_OFF)}	High side driver turn-off resistance	V _(BTST) - V _(PH) = 5 V		0.65	1.3	Ω
V _(BTST_REFRESH)	Bootstrap refresh comparator falling threshold voltage	V _(BTST) - V _(PH) when low side refresh pulse is requested	3.5	3.8	4.1	V
PWM LOW SIDE DRIVER (LODRV)						
R _{DS(LO_ON)}	Low side driver (LSD) turn-on resistance	V _(BTST) - V _(PH) = .55 V		5.5		Ω
R _{DS(LO_OFF)}	Low side driver turn-off resistance	V _(BTST) - V _(PH) = 5.5 V		1	1.45	Ω
INTERNAL SOFT START						
I _(CHG_DAC)	Soft start step size			64		mA
	Soft start step time			30		μs
INTEGRATED BTST DIODE						
V _F	Forward bias voltage	I _F = 20 mA at 25°C		0.8		V
V _R	Reverse breakdown voltage	I _R = 2 μA at 25°C			20	V
PWM DRIVERS TIMING						
t _{DEADTIME_RISE}	Driver dead time from low side to high side			20		ns
t _{DEADTIME_FALL}	Driver dead time from high side to low side			20		ns
LOGIC INPUT (SDA, SCL)						
V _(IN_LO)	Input low threshold	I2C (bq24773)			0.4	V
		SMBus (bq24770)			0.8	V
V _(IN_HI)	Input high threshold	I2C (bq24773)	1.3			V
		SMBus (bq24770)	2.1			V
LOGIC OUTPUT OPEN DRAIN (ACOK, SDA, CMPOUT)						
V _(OUT_LO)	Output saturation voltage	5 mA drain current			0.4	V
V _(OUT_LEAK)	Leakage current (ACOK, SDA, SCL)	V = 7 V	-1		1	μA
LOGIC OUTPUT OPEN DRAIN (PROCHOT)						
V _(OUT_LO)	Output saturation voltage	50 Ω pull up to 1.05 V/ 5mA load			300	mV
V _(OUT_LEAK)	Leakage current	V = 5.5 V	-1		1	μA
ANALOG INPUT (CELL)						
V _(CELL_HIGH)	3S/4S	REGN = 5.4 V	1.9			V
V _(CELL_FLOAT)	2S	REGN = 5.4 V	1.2		1.8	V

Electrical Characteristics (continued)

$4.5V \leq V_{(VCC)} \leq 24V$, $-20^{\circ}C \leq T_J \leq 125^{\circ}C$, typical values are at $T_A = 25^{\circ}C$, with respect to GND (unless otherwise noted)

PARAMETER		TEST CONDITION	MIN	TYP	MAX	UNIT		
$V_{(CELL_LOW)}$	1S	REGN = 5.4 V			1.1	V		
$R_{(CELL_UP)}$	Internal resistor between CELL and REGN			405		k Ω		
$R_{(CELL_DN)}$	Internal resistor between CELL and GND			141		k Ω		
ANALOG INPUT (/BATPRES)								
$V_{(BATPRES_RISE)}$	BATPRES pin rising threshold		BATPRES rising		2.1	2.2	2.3	V
$V_{(BATPRES_FALL)}$	BATPRES pin falling threshold		BATPRES falling		2	2.05	2.1	V

7.6 Timing Requirements

		MIN	TYP	MAX	UNIT
SMBus TIMING CHARACTERISTICS					
t_r	SCLK/SDATA rise time			1	μ s
t_f	SCLK/SDATA fall time			300	ns
$t_{W(H)}$	SCLK pulse width high	4		50	μ s
$t_{W(L)}$	SCLK Pulse Width Low	4.7			μ s
$t_{SU(STA)}$	Setup time for START condition	4.7			μ s
$t_{H(STA)}$	START condition hold time after which first clock pulse is generated	4			μ s
$t_{SU(DAT)}$	Data setup time	250			μ s
$t_{H(DTA)}$	Data hold time	300			μ s
$t_{SU(STOP)}$	Setup time for STOP condition	4			μ s
$t_{(BUF)}$	Bus free time between START and STOP condition	4.7			μ s
$F_{S(CL)}$	Clock Frequency	10		100	KHz
HOST COMMUNICATION FAILURE					
$t_{timeout}$	SMBus bus release timeout ⁽¹⁾	25		35	ms
t_{BOOT}	Deglitch for watchdog reset signal	10			ms
t_{WDI}	Watchdog timeout period, ChargeOption() bit [14:13] = 01 ⁽²⁾	35	44	53	s
	Watchdog timeout period, ChargeOption() bit [14:13] = 10 ⁽²⁾	70	88	105	s
	Watchdog timeout period, ChargeOption() bit [14:13] = 11 ⁽²⁾ (default)	140	175	210	s

- (1) Devices participating in a transfer will timeout when any clock low exceeds the 25ms minimum timeout period. Devices that have detected a timeout condition must reset the communication no later than the 35 ms maximum timeout period. Both a master and a slave must adhere to the maximum value specified as it incorporates the cumulative stretch limit for both a master (10 ms) and a slave (25 ms).
- (2) User can adjust threshold via SMBus ChargeOption() REG0x12.

7.7 Typical Characteristics

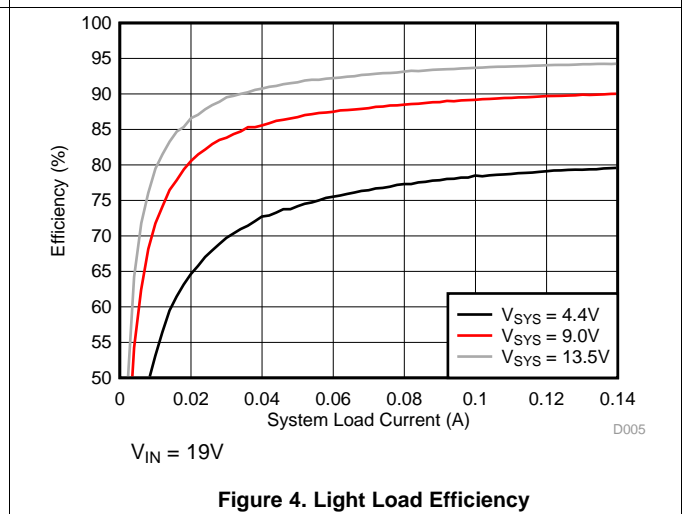
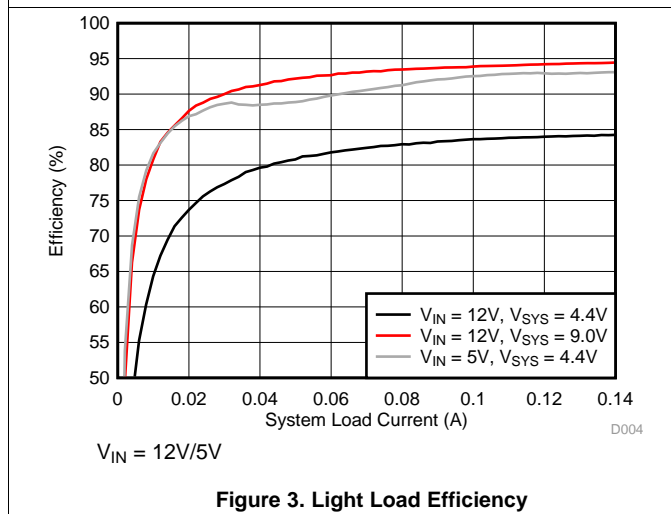
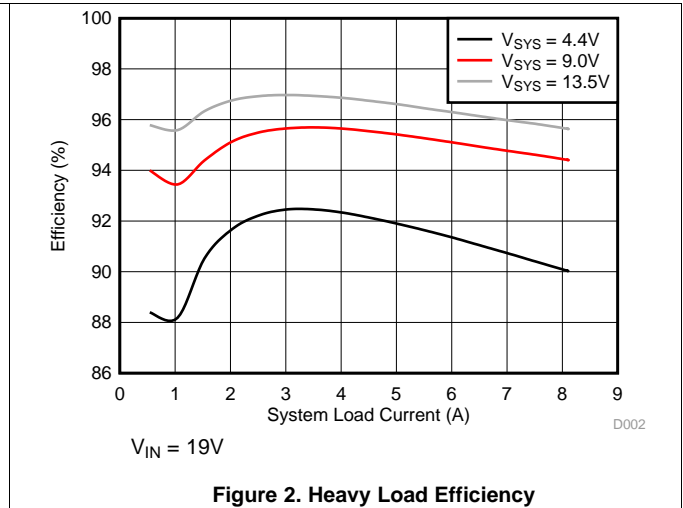
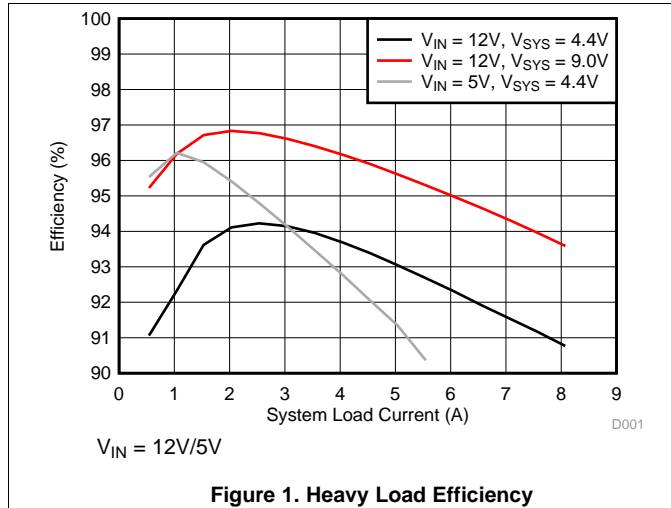

8 Detailed Description

8.1 Overview

The bq2477x is a 1-4 cell battery charge controller with power selection for space-constrained, multi-chemistry portable applications such as notebook and detachable ultrabook. It supports wide input range of input sources from 4.5V to 24V, and 1-4 cell battery for a versatile solution.

The bq2477x supports automatic system power source selection with separate drivers for n-channel MOSFETs on the adapter side, and p-channel MOSFETs on the battery side.

The bq2477x features Dynamic Power Management (DPM) to limit the input power and avoid AC adapter overloading. During battery charging, as the system power increases, the charging current will reduce to maintain total input current below adapter rating. If system power demand is temporarily exceeds adapter rating, the bq2477x supports NVDC architecture to allow battery discharge energy to supplement system power. For details, refer to the [System Voltage Regulation with Narrow VDC Architecture](#) section.

The bq2477x closely monitors system power (PMON), input current (IADP) and battery current (IBAT) with highly accurate current sense amplifiers. If current is too high, adapter or battery is removed, a PROCHOT signal is asserted to CPU so that the CPU optimizes its performance to the power available to the system.

The SMBus/I2C controls input current, charge current and charge voltage registers with high resolution, high accuracy regulation limits. It also sets the PROCHOT timing and threshold profile to meet system requirements.

8.2 Functional Block Diagram

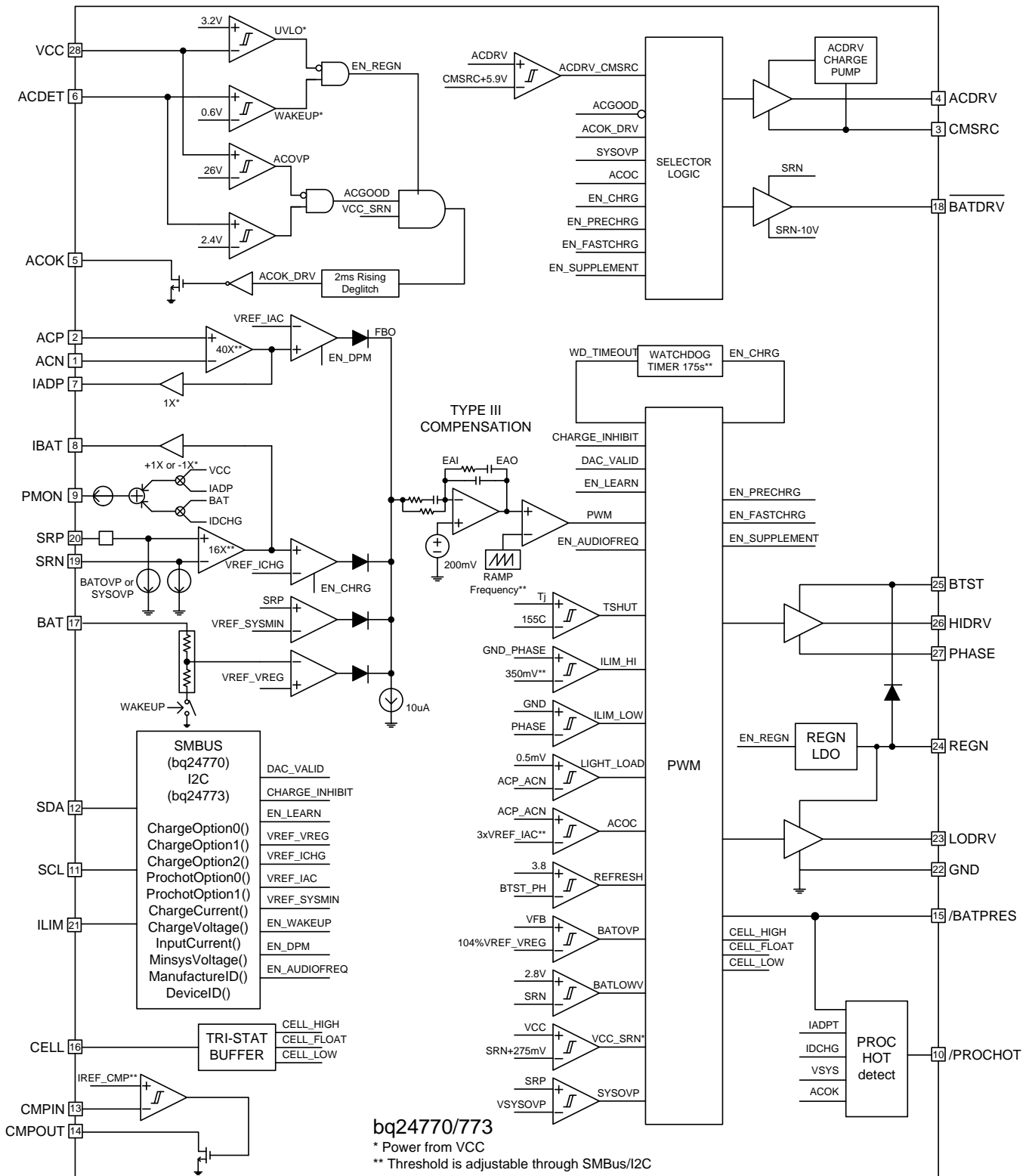

Copyright © 2016, Texas Instruments Incorporated

8.3 Feature Description

8.3.1 Battery Only

Battery is connected to VCC via diode. When VCC voltage is above UVLO, bq2477x powers up to turn on BATFET and starts SMBus/I2C communication. By default, bq2477x stays in low power mode (0x12[15] = 1) with lowest quiescent current.

When 0x12[15] is set to 0, the device enters performance mode. The user can enable IBAT buffer through SMBus/I2C. In order to enable PMON, PROCHOT or independent comparator, the bq2477x enables REGN LDO for accurate reference.

8.3.2 Adapter Detect and ACOK Output

An external resistor divider attenuates the adapter voltage before it goes to ACDET. The adapter detect threshold should typically be programmed to a value greater than the maximum battery voltage, but lower than the maximum allowed adapter voltage. When ACDET is above 0.6V, REGN LDO and bias circuits are enabled.

The open drain ACOK output can be pulled to external rail under the following conditions:

- $V_{(UVLO)} < V_{(VCC)} < V_{(ACOV)}$
- $V_{(ACDET)} > 2.4 \text{ V}$
- $V_{(VCC)} - V_{(SRN)} > V_{(VCC_SRN_RISE)}$

8.3.2.1 Adapter Overvoltage (ACOV)

When the VCC pin voltage is higher than 26 V, it is considered adapter over voltage. ACOK is pulled low, and charge is disabled. ACFET/RBFET are turned off to disconnect the high voltage adapter to system during ACOV. BATFET is turned on if turn-on conditions are valid. When VCC voltage falls below 22 V, it is considered as adapter voltage returns back to normal voltage. ACOK is pulled high by an external pullup resistor. BATFET is turned off and ACFET and RBFET is turned on to power the system from the adapter.

8.3.3 System Power Selection

The bq2477x device automatically switches adapter or battery power to system.

The ACDRV drives a pair of common-source (CMSRC) N-channel power MOSFETs (ACFET and RBFET) between adapter and ACP (see [Figure 21](#) for details). The ACFET separates adapter from system and battery, and provides a limited di/dt when plugging in adapter by controlling the ACFET turn-on time. The RBFET provides negative input voltage protection and battery discharge protection when adapter is shorted to ground, and minimizes system power dissipation with its low $R_{DS(on)}$ compared to a Schottky diode.

When the adapter is not present, ACDRV is pulled to CMSRC to keep ACFET and RBFET off, disconnecting the adapter from the system. BATDRV stays as low as $V_{SRN} - 10 \text{ V}$ to connect battery to system if all of the following conditions are valid:

- $V_{(VCC)} > V_{(UVLO)}$
- $V_{(SRN)} - V_{(SRP)} > 2.56 \text{ mV}$

After the adapter plugs in, the system power source switches from battery to adapter if ACOK is HIGH. The gate drive voltage on ACFET and RBFET is $V_{(CMSRC)} + 6 \text{ V}$. If ACDRV-CMSRC voltage drops at least 100 mV from its normal voltage, the converter stops.

To limit the adapter inrush current during ACFET turn-on, the Cgs and Cgd external capacitor of ACFET must be carefully selected following the guidelines below:

- Minimize total capacitance on system
- Cgs should be 40x or higher than Cgd to avoid ACFET false turn on during adapter hot plug-in
- Check with MOSFET vendor on peak current rating
- Place 4 kΩ resistor in series with ACDRV and CMSRC pins to limit MOSFET turn on/off time.

Feature Description (continued)

8.3.4 System Power Up

After the ACFET is turned on, the converter is enabled and the HSFET and LSFET start switching. Every time the buck converter is started, the IC automatically applies soft-start (no soft-start when exit LEARN) on buck output current to avoid any overshoot or stress on the output capacitors or the power converter. No external components are needed for this function.

When power up, the converter output voltage is a default value set by CELL pin configuration.

Table 1. Cell Pin Configuration

CELL PIN	DEFAULT BATTERY CONFIGURATION	DEFAULT MaxChargeVoltage()	DEFAULT MinSystemVoltage()	SYSOVP THRESHOLD
Low	1s	4400mV	3568mV	5 V
Float	2s	9008mV	6144mV	12 V
High	3s/4s	13504mV	9008mV	18.5 V when MaxChargeVoltage() < 15 V

8.3.4.1 Dynamic Power Management (IDPM) and Supplement Mode

When the input current exceeds the input current setting, the bq2477x decreases the charge current to provide priority to system load. As the system current rises, the available charge current drops accordingly toward zero. If the system load keeps increasing after charge current drops down to zero, the system voltage starts to drop. As the system voltage drops below battery voltage, the device enters supplement mode, the battery starts discharge, and the total system power equals to input supply power and battery discharge power.

8.3.4.2 Minimum System Voltage Regulation and LDO Mode

The $\overline{\text{BATDRV}}$ drives a p-channel BATFET between converter output and battery to provide a charge and discharge path for battery. The system is always above the MinSystemVoltage() even with depleted battery or without battery.

When battery voltage is below the minimum system voltage setting, this BATFET works in linear mode (LDO mode) during battery charging. The precharge current is set by ChargeCurrent() and clamped below 384mA. If battery voltage reaches the minimum system voltage, BATFET fully turns on.

The minimum $\overline{\text{BATDRV}}$ voltage is 1.1 V. For 1s application, the BATFET has to fully turn on when the gate voltage is 1.1 V or higher. Otherwise, BATFET may not operate properly.

8.3.5 Current and Power Monitor

8.3.5.1 High Accuracy Current Sense Amplifier (IADP and IBAT)

As an industry standard, a high-accuracy current sense amplifier (CSA) is used to monitor the input current (IADP) and the charge/discharge current (IBAT). IADP voltage is 40X or 80X the differential voltage across ACP and ACN. IBAT voltage is 20X (during charging), or 8X/16X (during discharging) of the differential across SRP and SRN. After VCC is above $V_{(UVLO)}$ and ACDET is above 0.6 V, IADP output becomes valid. To lower the voltage on current monitoring, a resistor divider from CSA output to GND can be used and accuracy over temperature can still be achieved.

A maximum 100-pF capacitor is recommended to connect on the output for decoupling high-frequency noise. An additional RC filter is optional, if additional filtering is desired. Note that adding filtering also adds additional response delay. The CSA output voltage is clamped at 3.3 V.

8.3.5.2 High Accuracy Power Sense Amplifier (PMON)

The bq2477x device monitors total available power from adapter and battery together. The ratio of PMON current and total power $K_{(PMON)}$ can be programmed in ChargeOption1() bit[8] with default 1 μ A/W. The bq2477x device allows input sense resistor 2x of charge sense resistor by setting ChargeOption1() bit[12] to 1.

$$I = K_{(PMON)}(V_{IN} \times I_{IN} + V_{BAT} \times I_{BAT}) \quad (I_{BAT} > 0 \text{ during battery discharging, } I_{BAT} < 0 \text{ during battery charging}) \quad (1)$$

A maximum PMON output current is 100 μ A. The user picks output resistor based on peak system power rating. The PMON output voltage is clamped below 3.3V.

8.3.6 Processor Hot Indication for CPU Throttling

When CPU is running turbo mode, the peak power may exceed total available power from adapter and battery. The adapter current and battery discharge overshoot, or system voltage drop indicates the system power may be too high. When the adapter or battery is removed, the remaining power source may not support the peak power in turbo mode. The processor hot function in bq2477x monitors these events, and $\overline{\text{PROCHOT}}$ pulse is asserted.

The $\overline{\text{PROCHOT}}$ triggering events include:

- ICRIT: adapter peak current
- INOM: adapter average current (110% of input current limit)
- IDCHG: battery discharge current
- VSYS: system voltage on SRN for 2s - 4s battery
- ACOK: upon adapter removal (ACOK pin HIGH to LOW)
- BATPRES: upon battery removal ($\overline{\text{BATPRES}}$ pin LOW to HIGH)
- CMPOUT: Independent comparator output (CMPOUT pin HIGH to LOW)

The threshold of ICRIT, IDCHG or VSYS, and the deglitch time of ICRIT, INOM, IDCHG or CMPOUT are programmable through SMBus. Each triggering event can be individually enabled in REG0x3D[6:0].

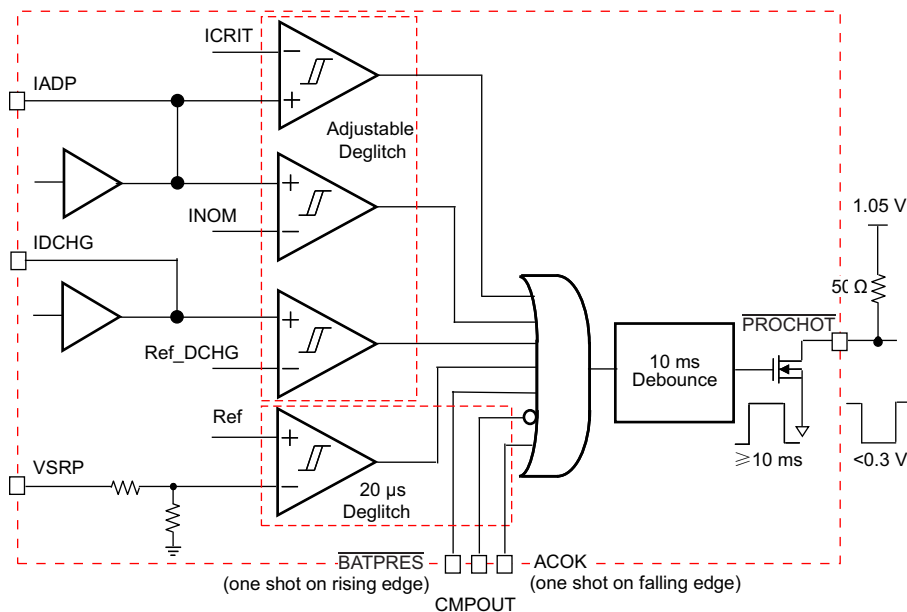

Figure 5. $\overline{\text{PROCHOT}}$ Profile

When any event in $\overline{\text{PROCHOT}}$ profile is triggered, $\overline{\text{PROCHOT}}$ is asserted low for minimum 10 ms (default 0x3C[4:3]). At the end of the 10 ms, if the $\overline{\text{PROCHOT}}$ event is still active, the pulse gets extended.

8.3.7 Converter Operation

The bq2477x typically use 2.2/3.3 μ H inductor and 60 μ F output capacitance to achieve all loops stable. This capacitance could be from system bus decoupling cap. But in order to achieve good output transient response, like mini output drop or min output spike, then it is better to have more output capacitance from the system bus, which could be the total input capacitance from the input of the down-stream DC-DC converters for CPU core, DDR and chip-set.

Ceramic capacitors show a DC-bias effect. This effect reduces the effective capacitance when a DC-bias voltage is applied across a ceramic capacitor, as on the output capacitor of a charger. The effect may lead to a significant capacitance drop, especially for high output voltages and small capacitor packages. See the manufacturer's data sheet about the performance with a DC bias voltage applied. It may be necessary to choose a higher voltage rating or nominal capacitance value to get the required value at the operating point.

8.3.7.1 Continuous Conduction Mode (CCM)

With sufficient charge current, the inductor current does not cross 0, which is defined as CCM. The controller starts a new cycle with ramp coming up from 200 mV. As long as EAO voltage is above the ramp voltage, the high-side MOSFET (HSFET) stays on. When the ramp voltage exceeds EAO voltage, HSFET turns off and lowside MOSFET (LSFET) turns on. At the end of the cycle, ramp gets reset and LSFET turns off, ready for the next cycle. There is always break-before-make logic during transition to prevent cross-conduction and shoot-through. During the dead time when both MOSFETs are off, the body-diode of the low-side power MOSFET conducts the inductor current.

During CCM, the inductor current always flows and creates a fixed two-pole system. Having the LSFET turn-on keeps the power dissipation low and allows safe charging at high currents.

8.3.7.2 Discontinuous Conduction Mode (DCM)

During the HSFET off time when LSFET is on, the inductor current decreases. If the current goes to 0, the converter enters DCM. Every cycle, when the voltage across SRP and SRN falls below 0 mV, the undercurrent-protection comparator (UCP) turns off LSFET to avoid negative inductor current, which may boost the system through the body diode of HSFET.

During DCM the loop response automatically changes. It changes to a single-pole system and the pole is proportional to the load current.

8.3.7.3 PFM Mode

In order to improve converter light-load efficiency, the bq2477x switches to PFM control at light load with charge disable or charge in LDO mode. The effective switching frequency will decrease accordingly when system load decreases. The minimum frequency can be limit to 40kHz (ChargeOption0() bit[10]=1). To have higher light load efficiency, set "Audio Frequency Limit" bit low (Chargeoption0() bit[10]=0).

8.3.7.4 Switching Frequency Adjust

The charger switching frequency can be adjusted to solve EMI issue via SMBus/I2C command. ChargeOption0() bit [9:8] can be used to set switching frequency. If frequency is reduced, the current ripple is increased. Inductor value must be carefully selected so that it will not trigger cycle-by-cycle peak over current protection even for the worst condition such as higher input voltage, 50% duty cycle, lower inductance and lower switching frequency.

8.3.8 Learn Mode

LEARN mode is set up to calibrate gauge in the pack. When LEARN is enabled, the system first discharge the battery below depletion threshold, and complete another charging cycle for gauge calibration. During the discharging, BATFET turns on and converter stops.

A battery LEARN cycle can be activated via SMBus/I2C "LEARN Enable" command (ChargeOption0() bit[5]=1 enable Learn Mode). When LEARN is enabled with an adapter connected, the system power switch to battery by turning off converter and keep ACFET/BATFET on. Learn mode allows the battery to discharge in order to calibrate the battery gas gauge over a complete discharge/charge cycle. When LEARN is disabled, the system power switch to adapter by turning on converter in a few hundreds μ s.

bq2477x also supports hardware pin to exist LEARN mode by driving $\overline{\text{BATPRES}}$ to HIGH. When $\overline{\text{BATPRES}}$ pin is pulled to HIGH, bq2477x resets "LEARN Enable" (ChargeOption0() bit[5]) and IDPM_EN (ChargeOption() bit[1]), and reset MaxChargeVoltage() and ChargeCurrent().

8.3.9 Charger Timeout

The bq2477x includes a watchdog timer to terminate charging if the charger does not receive a write MaxChargeVoltage() or write ChargeCurrent() command within 175s (adjustable via ChargeOption() command). If a watchdog timeout occurs all register values keep unchanged but charge is suspended. Write ChargeVoltage() or write ChargeCurrent() commands must be re-sent to reset watchdog timer and resume charging. The watchdog timer can be disabled, or set to 44s, 88s or 175s via SMBus command (ChargeOption() bit[14:13]). If watchdog is in timeout, disabling watchdog timer by writing ChargeOption() bit[14:13] also resumes charging.

8.3.10 Device Protection Features

8.3.10.1 Input Overcurrent Protection (ACOC)

If the input current exceeds the 3X of input current DAC set point, the converter is disabled. After 300ms, the converter is turned on again.

The ACOG function threshold can be set to 3X of input DPM current (ChargeOption0 bit [7]=1) or function disable (ChargeOption0) bit [7]=0, default) via SMBus command. The bq2477x has a cycle-to-cycle peak overcurrent protection. It monitors the voltage across $R_{ds(on)}$ of the LSFET or the input current sense resistor, and prevents the converter from over current condition. The high-side gate drive turns off when the overcurrent is detected, and resumes automatically when the overcurrent condition is gone.

8.3.10.2 Converter Overcurrent Protection

When LODRV pulse is longer than 100ns, the LSFET OCP is active and the threshold is automatically set to 290mV (ChargeOption0() bit [6]=1, default) or 170mV (ChargeOption0() bit [6]=0) via SMBus/I2C command. The blanking time prevents noise when MOSFET just turn on.

When LODRV pulse is shorter than 100ns, bq2477x sets OCP limit proportional to $\overline{\text{PROCHOT}}$ ICRIT setting (ProchotOption0() bit[8]). The IDPM function is disabled (0x12[1]=0). Set InputCurrent() to a right value even IDPM is disabled.

8.3.10.3 Battery Overvoltage Protection (BATOVP)

The bq2477x immediately stops the converter when the voltage at BAT exceeds 104% (1s) or 102% (2s – 4s) of the regulation voltage set-point. This allows quick response to an overvoltage condition – such as occurs when the load is removed or the battery is disconnected. A 19 mA current sink from SRP/SRN to GND is on only during BATOVP and allows discharging the stored output inductor energy that is transferred to the output capacitors.

8.3.10.4 System Overvoltage Protection (SYSOVP)

When the converter starts up, the bq24770 reads CELL pin configuration and sets MaxChargeVoltage() and SYSOVP threshold (1s – 5 V, 2s – 12 V, 3s – 18.5 V). Before MaxChargeVoltage() is written by host, the battery configuration will change with CELL pin voltage.

When SYSOVP happens, the device latches off ACFET/RBFET. Register ChargeOption0() bit[12] is set as 1.

The user can clear the latch off by either write of 0 to register bit or removal and plugin adapter again (ACDET below 0.6V and back up again). After the latch-off is cleared, ACFET/RBFET turn on and converter starts.

8.3.10.5 Thermal Shutdown Protection (TSHUT)

The WQFN package has low thermal impedance, which provides good thermal conduction from the silicon to the ambient, to keep junction temperatures low. As an added level of protection, the charger converter turns off for self-protection whenever the junction temperature exceeds the 155°C. The charger stays off until the junction temperature falls below 135°C. During thermal shutdown, the REGN LDO current limit is reduced to 14 mA.

Once the temperature falls below 135°C, charge can be resumed with soft start.

8.4 Device Functional Modes

8.4.1 Battery Charging

The bq2477x charges 1-4 cell battery in constant current (CC), and constant voltage (CV) mode. The host programs battery voltage to ChargeVoltage() (0x15()). According to battery voltage, the host programs appropriate charge current to ChargeCurrent() (0x14()). When battery is full or battery is not in good condition to charge, host terminates charge by setting 0x12[0] to 1, or setting ChargeCurrent() to zero.

See the [Feature Description](#) section for details on charge enable conditions and register programming.

8.4.2 System Voltage Regulation with Narrow VDC Architecture

The bq2477x deploys Narrow VDC architecture (NVDC) with BATFET separating system from battery. The minimum system voltage is set by MinSystemVoltage(). Even with a deeply depleted battery, the system is regulated above the minimum system voltage.

When the battery is below minimum system voltage setting, the BATFET operates in linear mode (LDO mode). As the battery voltage rises above the minimum system voltage, BATFET is fully on and the voltage difference between the system and battery is the VDS of BATFET.

See the [Feature Description](#) section for details on system voltage regulation and register programming.

8.5 Programming

8.5.1 SMBus Interface

The bq24770 device operates as a slave, receiving control inputs from the embedded controller host through the SMBus interface. The bq24770 device uses a simplified subset of the commands documented in *System Management Bus Specification V1.1*, which can be downloaded from www.smbus.org. The bq24770 device uses the SMBus read-word and write-word protocols (shown in [Table 2](#) and [Table 3](#)) to communicate with the smart battery. The bq24770 device performs only as a SMBus slave device with address 0b00010010 (0x12H) and does not initiate communication on the bus. In addition, the bq24770 device has two identification registers, a 16-bit device ID register (0xFFH) and a 16-bit manufacturer ID register (0xFEH).

SMBus/I2C communication starts when VCC is above $V_{(UVLO)}$.

The data (SDA) and clock (SCL) pins have Schmitt-trigger inputs that can accommodate slow edges. Choose pullup resistors (10 k Ω) for SDA and SCL to achieve rise times according to the SMBus specifications. Communication starts when the master signals a start condition, which is a high-to-low transition on SDA, while SCL is high. When the master has finished communicating, the master issues a stop condition, which is a low-to-high transition on SDA, while SCL is high. The bus is then free for another transmission. [Figure 6](#) and [Figure 7](#) show the timing diagram for signals on the SMBus interface. The address byte, command byte, and data bytes are transmitted between the start and stop conditions. The SDA state changes only while SCL is low, except for the start and stop conditions. Data is transmitted in 8-bit bytes and is sampled on the rising edge of SCL. Nine clock cycles are required to transfer each byte in or out of the bq2477x device because either the master or the slave acknowledges the receipt of the correct byte during the ninth clock cycle. The bq2477x supports the charger commands listed in [Table 2](#).

Programming (continued)

8.5.1.1 SMBus Write-Word and Read-Word Protocols

Table 2. Write-Word Format

S ⁽¹⁾⁽²⁾	SLAVE ADDRESS ⁽¹⁾	W ⁽¹⁾⁽³⁾	ACK ⁽⁴⁾⁽⁵⁾	COMMAND BYTE ⁽¹⁾	ACK ⁽⁴⁾⁽⁵⁾	LOW DATA BYTE ⁽¹⁾	ACK ⁽⁴⁾⁽⁵⁾	HIGH DATA BYTE ⁽¹⁾	ACK ⁽⁴⁾⁽⁵⁾	P ⁽¹⁾⁽⁶⁾
	7 bits	1b	1b	8 bits	1b	8 bits	1b	8 bits	1b	
	MSB LSB	0	0	MSB LSB	0	MSB LSB	0	MSB LSB	0	

- (1) Master to slave
- (2) S = Start condition or repeated start condition
- (3) W = Write bit (logic-low)
- (4) Slave to master (shaded gray)
- (5) ACK = Acknowledge (logic-low)
- (6) P = Stop condition

Table 3. Read-Word Format

S ⁽¹⁾⁽²⁾	SLAVE ADDRESS ⁽¹⁾	W ⁽¹⁾⁽³⁾	ACK ⁽⁴⁾⁽⁵⁾	COMMAND BYTE ⁽¹⁾	ACK ⁽⁴⁾⁽⁵⁾	S ⁽¹⁾⁽²⁾	SLAVE ADDRESS ⁽¹⁾	R ⁽¹⁾⁽⁶⁾	ACK ⁽⁴⁾⁽⁵⁾	LOW DATA BYTE ⁽⁴⁾	ACK ⁽¹⁾⁽⁵⁾	HIGH DATA BYTE ⁽⁴⁾	NACK ⁽¹⁾⁽⁷⁾	P ⁽¹⁾⁽⁸⁾
	7 bits	1b	1b	8 bits	1b		7 bits	1b	1b	8 bits	1b	8 bits	1b	
	MSB LSB	0	0	MSB LSB	0		MSB LSB	1	0	MSB LSB	0	MSB LSB	1	

- (1) Master to slave
- (2) S = Start condition or repeated start condition
- (3) W = Write bit (logic-low)
- (4) Slave to master (shaded gray)
- (5) ACK = Acknowledge (logic-low)
- (6) R = Read bit (logic-high)
- (7) NACK = Not acknowledge (logic-high)
- (8) P = Stop condition

8.5.1.2 Timing Diagrams

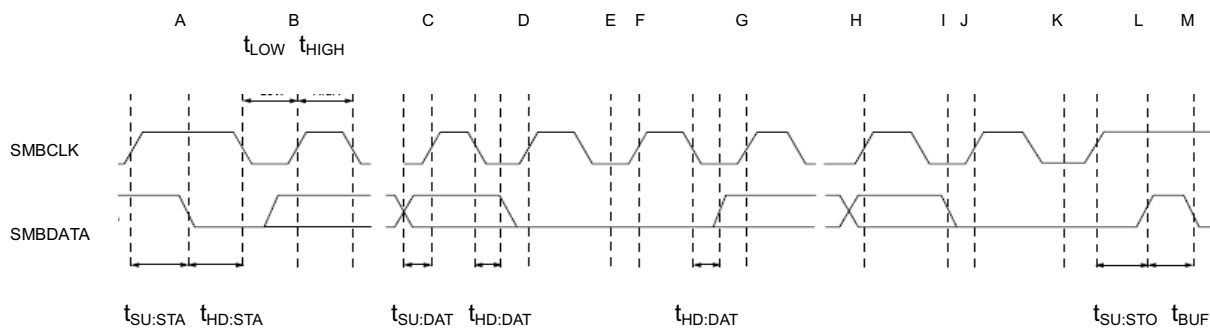

- A = Start condition
- B = MSB of address clocked into slave
- C = LSB of address clocked into slave
- D = R/W bit clocked into slave
- E = Slave pulls SMBDATA line low
- F = ACKNOWLEDGE bit clocked into master
- G = MSB of data clocked into slave
- H = LSB of data clocked into slave
- I = Slave pulls SMBDATA line low
- J = Acknowledge clocked into master
- K = Acknowledge clock pulse
- L = Stop condition, data executed by slave
- M = New start condition

Figure 6. SMBus Write Timing

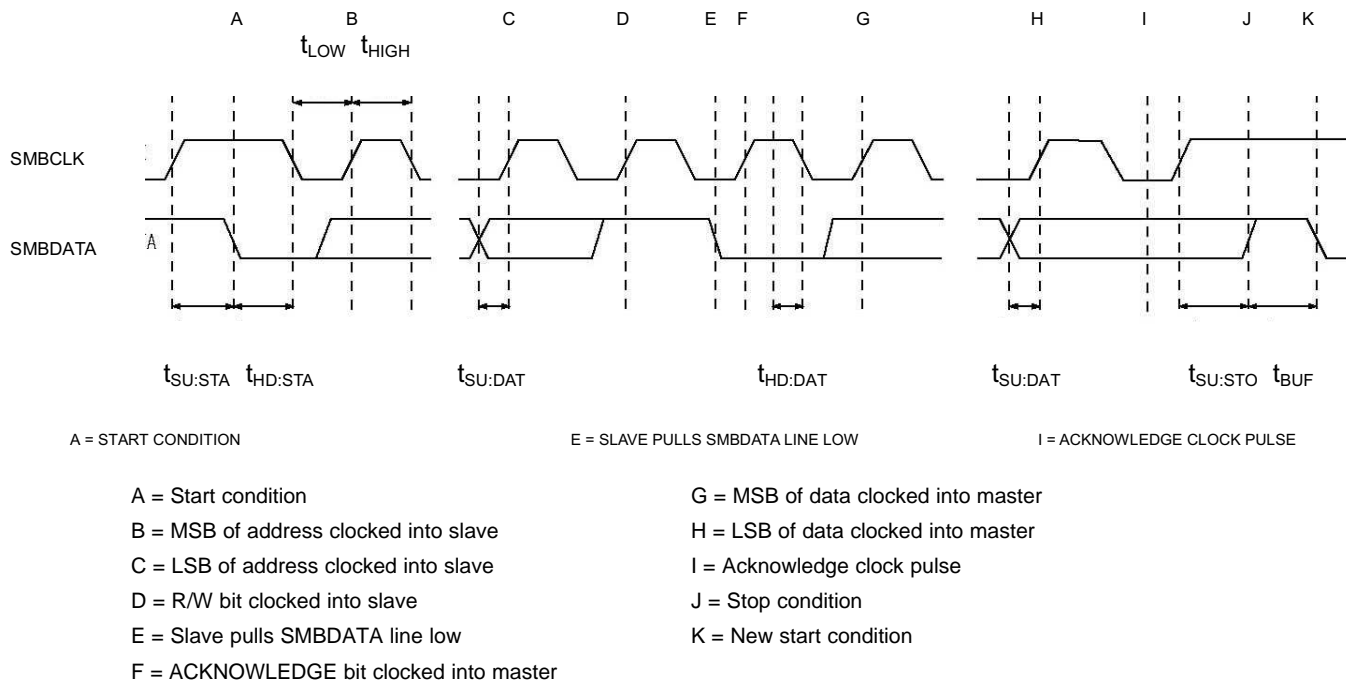

Figure 7. SMBus Read Timing

8.5.2 I²C Serial Interface

The bq24773 uses I²C compatible interface for flexible charging parameter programming and instantaneous device status reporting. I²C is a bi-directional 2-wire serial interface. Only two bus lines are required: a serial data line (SDA) and a serial clock line (SCL). Devices can be considered as masters or slaves when performing data transfers. A master is the device which initiates a data transfer on the bus and generates the clock signals to permit that transfer. At that time, any device addressed is considered a slave.

The device operates as a slave device with address D4H, receiving control inputs from the master device like micro controller or a digital signal processor through REG00-REG0F. The I²C interface supports both standard mode (up to 100kbits), and fast mode (up to 400kbits), connecting to the positive supply voltage via a current source or pull-up resistor. When the bus is free, both lines are HIGH. The SDA and SCL pins are open drain.

8.5.2.1 Data Validity

The data on the SDA line must be stable during the HIGH period of the clock. The HIGH or LOW state of the data line can only change when the clock signal on the SCL line is LOW. One clock pulse is generated for each data bit transferred.

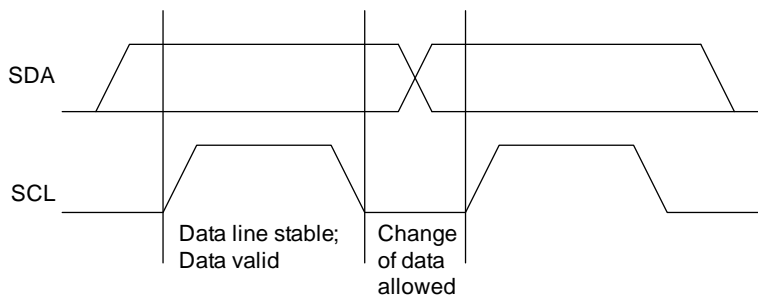

Figure 8. Bit Transfer on the I²C Bus

8.5.2.2 START and STOP Conditions

All transactions begin with a START (S) and can be terminated by a STOP (P). A HIGH to LOW transition on the SDA line while SCL is HIGH defines a START condition. A LOW to HIGH transition on the SDA line when the SCL is HIGH defines a STOP condition.

START and STOP conditions are always generated by the master. The bus is considered busy after the START condition, and free after the STOP condition.

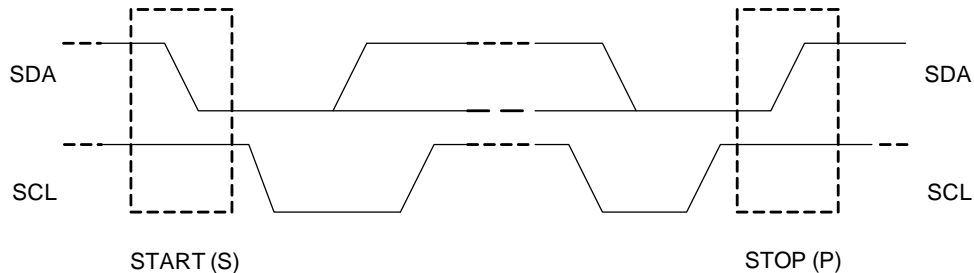

Figure 9. START and STOP Conditions

8.5.2.3 Byte Format

Every byte on the SDA line must be 8 bits long. The number of bytes to be transmitted per transfer is unrestricted. Each byte has to be followed by an Acknowledge bit. Data is transferred with the Most Significant Bit (MSB) first. If a slave cannot receive or transmit another complete byte of data until it has performed some other function, it can hold the clock line SCL low to force the master into a wait state (clock stretching). Data transfer then continues when the slave is ready for another byte of data and release the clock line SCL.

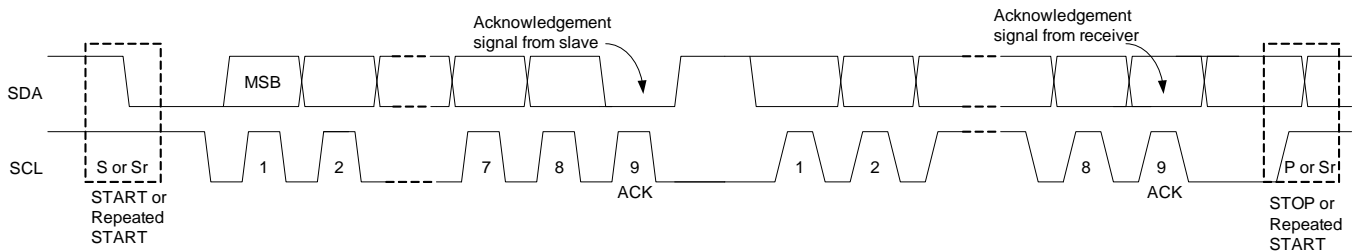

Figure 10. Data Transfer on the I²C Bus

8.5.2.4 Acknowledge (ACK) and Not Acknowledge (NACK)

The acknowledge takes place after every byte. The acknowledge bit allows the receiver to signal the transmitter that the byte was successfully received and another byte may be sent. All clock pulses, including the acknowledge 9th clock pulse, are generated by the master.

The transmitter releases the SDA line during the acknowledge clock pulse so the receiver can pull the SDA line LOW and it remains stable LOW during the HIGH period of this clock pulse.

When SDA remains HIGH during the 9th clock pulse, this is the Not Acknowledge signal. The master can then generate either a STOP to abort the transfer or a repeated START to start a new transfer.

8.5.2.5 Slave Address and Data Direction Bit

After the START, a slave address is sent. This address is 7 bits long followed by the eighth bit as a data direction bit (bit R/W). A zero indicates a transmission (WRITE) and a one indicates a request for data (READ).

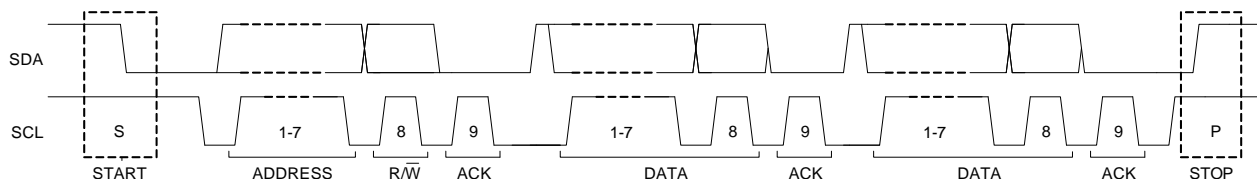

Figure 11. Complete Data Transfer

8.5.2.6 Single Read and Write

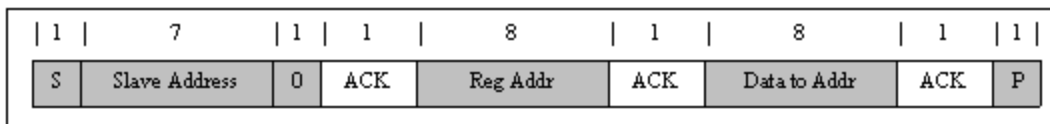

Figure 12. Single Write

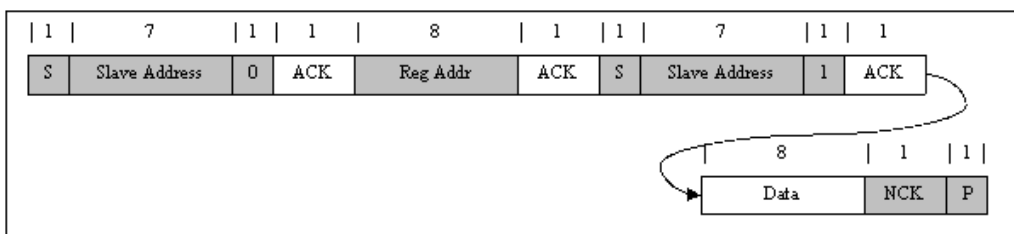

Figure 13. Single Read

If the register address is not defined, the charger IC send back NACK and go back to the idle state.

8.5.2.7 Multi-Read and Multi-Write

The charger device supports multi-read and multi-write.

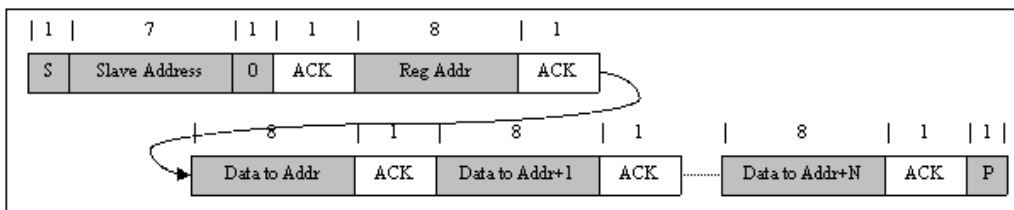

Figure 14. Multi Write

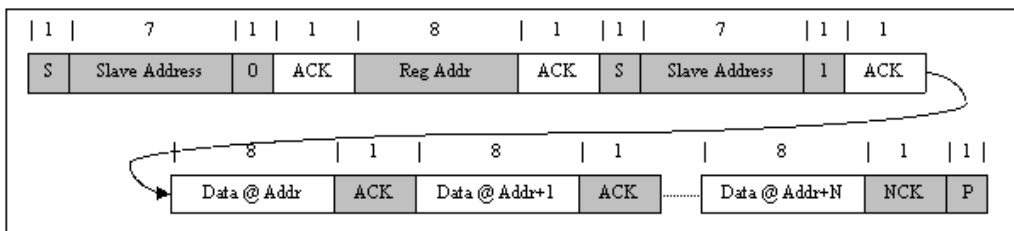

Figure 15. Multi Read

8.6 Register Maps

The bq2477x supports battery-charger commands that use either Write-Word or Read-Word protocols, as summarized in [Table 4](#). The SMBUS address is 0x12H or 0001001_X, and I2C address is D4H or 1101010_X, where X is the read/write bit. ManufacturerID() and DeviceID() can be used to identify the bq2477x. The ManufacturerID() command always returns 0x0040H.

Table 4. Battery Charger Command Summary

REGISTER ADDRESS	REGISTER NAME	R/W	DESCRIPTION	POR STATE
SMBus: 0x12H I2C: 01H/00H	ChargeOption0()	R/W	Charger Option Control 0	0xE14EH
SMBus: 0x3B I2C: 03H/02H	ChargeOption1()	R/W	Charge Option Control 1	0x0211H
SMBus: 0x38H I2C: 11H/10H	ChargeOption2()	R/W	Charge Options Control 2	0x0080H
SMBus: 0x3CH I2C: 05H/04H	ProchotOption0()	R/W	$\overline{\text{PROCHOT}}$ Option 0	0x4B54H
SMBus: 0x3DH I2C: 07H/06H	ProchotOption1()	R/W	$\overline{\text{PROCHOT}}$ Option 1	0x8120H
SMBus: 0x14H I2C: 0BH/0AH	ChargeCurrent()	R/W	7-Bit Charge Current Setting	0x0000H
SMBus: 0x15H I2C: 0DH/0CH	MaxChargeVoltage()	R/W	11-Bit Charge Voltage Setting	1S-4.4V, 2S-9.008V, 3S/4S-13.504V
SMBus: 0x3EH I2C: 0EH	MinSystemVoltage()	R/W	6-Bit Minimum System Voltage Setting	1S-3.584V, 2S-6.144V, 3S/4S-9.216V
SMBus: 0x3FH I2C: 0FH	InputCurrent()	R/W	7-Bit Input Current Setting	3200mA (770), 2944mA (773)
SMBus: 0xFEH	ManufacturerID()	Read Only	Manufacturer ID	0x0040H
SMBus: 0xFFH I2C: 09H	DeviceAddress()	Read Only	Device Address	0x0114H (770) 0x41H (773)

8.6.1 ChargeOption0 Register

Figure 16. ChargeOption0 Register (0x12H)

15	14	13	12	11	10	9	8
Low Power Mode Enable	WATCHDOG Timer Adjust		IDPM AUTO DISABLE	SYSOVP Status& Clear	Audio Frequency Limit	Switching Frequency[1:0]	
R/W	R/W		R/W	R/W	R/W	R/W	
7	6	5	4	3	2	1	0
ACOC Setting	LSFET OCP Threshold	LEARN Enable	IADP Amplifier Ratio	IBAT Amplifier Ratio for Discharge Current	Reserved	IDPM Enable	Charge Inhibit
R/W	R/W	R/W	R/W	R/W	R	R/W	R/W

LEGEND: R/W = Read/Write; R = Read only; -n = value after reset

Table 5. ChargeOption0 Register (0x12H)

I2C 01H	I2C 00H	SMBus 0x12H	BIT NAME	DESCRIPTION
[7]		[15]	Low Power Mode Enable	0: IC in performance mode with battery only. The enable of $\overline{\text{PROCHOT}}$, current monitor buffer, power monitor buffer and comparator follow register setting. 1: IC in low power mode with battery only. IC is in the lowest quiescent current when this bit is enabled. /PROCHOT, discharge current monitor buffer, power monitor buffer and independent comparator are disabled. <default at POR>
[6:5]		[14:13]	WATCHDOG Timer Adjust	Set maximum delay between consecutive SMBus/I2C Write charge voltage or charge current command. If IC does not receive write on MaxChargeVoltage() or ChargeCurrent() within the watchdog time period, ChargeCurrent() is set to 0mA to stop charging. The converter keeps running to regulate the system voltage. After expiration, the timer will resume upon the write of MaxChargeVoltage() or ChargeCurrent(). 00: Disable Watchdog Timer 01: Enabled, 44 sec 10: Enabled, 88 sec 11: Enable Watchdog Timer (175s) <default at POR>
[4]		[12]	IDPM AUTO DISABLE	When the $\overline{\text{BATPRES}}$ pin goes from LOW to HIGH, the charger IC automatically disables the IDPM function (IDPM Enable bit becomes 0). The host can enable IDPM function again by writing IDPM_EN bit 1. 0 – Disable this function <default at POR> 1 – Enable this function
[3]		[11]	SYSOVP Status& Clear	When the SYSOVP occurs, the bit is HIGH. After the SYSOVP is removed, the user must write a 0 to this register or unplug the adapter to clear the OVP condition. 0: not in SYSOVP, write 0 to clear SYSOVP latch <default at POR> 1: Device in SYSOVP, ACFET/RBFET latches off
[2]		[10]	Audio Frequency Limit	0: No limit of switching frequency <default at POR> 1: Set minimum switching frequency to 40kHz to avoid audio noise
[1:0]		[9:8]	Switching Frequency[1:0]	Converter switching frequency. 00: 600 kHz 01: 800kHz <default at POR in bq24770> 10: 1 MHz 11: 1.2MHz <default at POR in bq24773>
	[7]	[7]	ACOC Setting	Input over-current protection threshold by detecting ACP_ACN voltage. 0: disable ACOC <default at POR> 1: ACOC limit 300% of IDPM
	[6]	[6]	LSFET OCP Threshold	Cycle-by-cycle over-current protection threshold by detecting GND-PHASE 0: 170mV 1: 290mV <default at POR>
	[5]	[5]	LEARN Enable	Battery LEARN mode enable. In LEARN mode, buck converter turns off while ACFET and RBFET stay on. The BATFET turns on to discharge. Set this bit 0 will stop LEARN mode and turn back on buck converter. 0: Disable LEARN Mode <default at POR> 1: Enable LEARN Mode
	[4]	[4]	IADP Amplifier Ratio	0: 40x <default at POR> 1: 80x
	[3]	[3]	IBAT Amplifier Ratio for Discharge Current	0: 8x 1: 16x <default at POR>
	[2]	[2]	Reserved	1- Reserved
	[1]	[1]	IDPM Enable	Input regulation loop enable. 0 – IDPM disabled 1 – IDPM enabled <default at POR>
	[0]	[0]	Charge Inhibit	Change inhibit bit. To enable charge, first writes this bit to 0 and then write 0x14() non-zero value. 0: Enable charge <default at POR> 1: Disable charge

8.6.2 ChargeOption1 Register

Figure 17. ChargeOption1 Register (0x3BH)

15	14	13	12	11	10	9	8
Reserved			RSNS_RATIO	IBAT Enable	PMON Enable	PMON Gain	Reserved
R			R/W	R/W	R/W	R/W	R
7	6	5	4	3	2	1	0
CMP_REF	CMP_POL	CMP_DEG [1:0]		FET Latch-off Enable	FORCE BATFET Off	Discharge BAT Enable	Auto Wakeup Enable
R/W	R/W	R/W		R/W	R/W	R/W	R/W

LEGEND: R/W = Read/Write; R = Read only; -n = value after reset

Table 6. ChargeOption1 Register (0x3BH)

I2C 03H	I2C 02H	SMBus 0x3BH	BIT NAME	DESCRIPTION
[7:5]		[15:13]		0- Reserved
[4]		[12]	RSNS_RATIO	Adjust ratio of input sense resistor (RAC) and charge sense resistor (RSR) for power calculation. 0: RAC and RSR 1:1 <default at POR> 1: RAC and RSR 2:1
[3]		[11]	IBAT Enable	Enable the IBAT output buffer. 0: Turn off IBAT buffer to minimize Iq <default at POR> 1: Turn on IBAT buffer
[2]		[10]	PMON Enable	Enable PMON sensing circuit and output buffer. 0: turn off PMON buffer to minimize Iq <default at POR> 1: turn on PMON buffer
[1]		[9]	PMON Gain	PMON output current with respect to the total system power on 10mohm RAC and RSR. 0: 0.25 μ A/W 1: 1μA/W <default at POR>
[0]		[8]	Reserved	0- Reserved
	[7]	[7]	CMP_REF	Independent comparator internal reference. 0: 2.3 V <default at POR> 1: 1.2 V
	[6]	[6]	CMP_POL	Independent comparator output polarity 0: When CMPIN is above internal threshold, CMPOUT is LOW <default at POR> 1: When CMPIN is above internal threshold, CMPOUT is HIGH
	[5:4]	[5:4]	CMP_DEG [1:0]	Independent comparator deglitch time. 00: Independent comparator is disabled 01: Independent comparator is enabled with output deglitch time 2 μs <default at POR> 10: Independent comparator is enabled with output deglitch time 2 ms 11: Independent comparator is enabled with output deglitch time 5 sec
	[3]	[3]	FET Latch-off Enable	When comparator is triggered, all the power path MOSFETs latch off. In order to clear power path latch off, both adapter and battery have to be removed. Therefore, at POR state, the latch off is cleared. 0: When comparator is triggered, no power path latch off <default at POR> 1: When comparator is triggered, power path latches off
	[2]	[2]	FORCE BATFET Off	The host can force BATFET to turn off at any time. After BATFET is forced off, plugin adapter will set the bit back to 0. 0: Allow BATFET turn on <default at POR> 1: Turn off BATFET
	[1]	[1]	Discharge BAT Enable	When this bit is 1, discharge BAT pin down below 3.8 V in 40 ms. When 40ms is over, this bit is reset to 0. 0 : Disable discharge mode <default at POR> 1: Enable discharge mode
	[0]	[0]	Auto Wakeup Enable	When this bit is HIGH, if the battery is below 3 V(1s) or 6 V(2s-4s), the IC will automatically enable 128 mA charging current to charge depleted battery for 30 mins. When the battery voltage exceeds 3 V (1S) or 6 V (2S-4S), the charge will stop after 1min deglitch time. After the 30 mins expires, the charging will stop, and this bit is set back to LOW. 0: Disable auto-wakeup 1: Enable auto-wakeup <default at POR>

8.6.3 ChargeOption2 Register

Figure 18. ChargeOption2 Register (0x38H)

15	14	13	12	11	10	9	8
Reserved							
R							
7	6	5	4	3	2	1	0
External ILIM Enable	IBAT Output Select	Reserved					
R/W	R/W	R					

LEGEND: R/W = Read/Write; R = Read only; -n = value after reset

Table 7. ChargeOption2 Register (0x38H)

	I2C 10H	SMBus 0x38H	BIT NAME	DESCRIPTION
		[15:8]		0- Reserved
	[7]	[7]	External ILIM Enable	0: Input current limit is set by REG0x3F. 1: Input current limit is set by the lower value of ILIM pin and REG0x3F. <default at POR>
	[6]	[6]	IBAT Output Select	0: IBAT pin as discharge current. <default at POR> 1: IBAT pin as charge current.
	[5:0]	[5:0]	Reserved	0- Reserved

8.6.4 ProchotOption0 Register
Figure 19. ProchotOption0 Register (0x3CH)

15	14	13	12	11	10	9	8
ICRIT Comparator Threshold					ICRIT Comparator Deglitch Time		Input OCP Threshold
R/W					R/W		R/W
7	6	5	4	3	2	1	0
VSYS comparator threshold	$\overline{\text{PROCHOT}}$ Pulse Extension Enable		$\overline{\text{PROCHOT}}$ Pulse Width		$\overline{\text{PROCHOT}}$ Host Clear	INOM Comparator Deglitch Time	Reserved
R/W		R/W		R/W	R/W	R	

LEGEND: R/W = Read/Write; R = Read only; -n = value after reset

Table 8. ProchotOption0 Register (0x3CH)

I2C 05H	I2C 04H	SMBus 0x3CH	BIT NAME	DESCRIPTION
[7:3]		[15:11]	ICRIT Comparator Threshold	5 bits, percentage of IDPM in 0x3FH. Measure current between ACP and ACN. Trigger when the current is above this threshold. Step: 5%, Default 150% (01001) 00000:110% 00001:110% 00010:115% 00011:120% ... 10111:220% 11000:225% 11001:230% 11010:250% 11011:300% 11100:350% 11101:400% 11110:450% 11111:Out of Range If IDPM setting exceeds 3.584A (0111000), ICRIT threshold is clamped at 230%.
[2:1]		[10:9]	ICRIT Comparator Deglitch Time	00: 10 μ s 01: 100 μs <default at POR> 10: 400 μ s 11: 800 μ s
[0]		[8]	Input OCP Threshold	Input over-current setting by detecting ACP-ACN. 0: 125% of ICRIT 1: 200% of ICRIT <default at POR>
	[7:6]	[7:6]	VSYS comparator threshold	Measure on SRP with fixed 20us deglitch time. Trigger when SRP voltage is below the threshold. 00: 5.75 V (2-4s) or 2.85 V (1s) 01: 6V (2-4s) or 3.1V (1s) <default at POR> 10: 6.25 V (2-4s) or 3.3 5V (1s) 11: 6.5 V (2-4s) or 3.6 V (1s)
	[5]	[5]	$\overline{\text{PROCHOT}}$ Pulse Extension Enable	When pulse extension is enabled, keep $\overline{\text{PROCHOT}}$ pin voltage low until host writes 0x3C[2]=1. 0: Pulse width is set by REG0x3C[4:3] <default at POR> 1: Pulse stays LOW till host sets REG0x3C[2] to 0.
	[4:3]	[4:3]	$\overline{\text{PROCHOT}}$ Pulse Width	Minimum $\overline{\text{PROCHOT}}$ pulse width when REG0x3C[5]=0 00: 100 μ s 01: 1 ms 10: 12 ms <default at POR> 11: 6 ms
	[2]	[2]	$\overline{\text{PROCHOT}}$ Host Clear	Clear $\overline{\text{PROCHOT}}$ pulse when REG0x3C[5]=1. 0: Clear $\overline{\text{PROCHOT}}$ pulse and drive / $\overline{\text{PROCHOT}}$ pin to HIGH. 1: Idle <default at POR>
	[1]	[1]	INOM Comparator Deglitch Time	INOM is always 10% above IDPM in 0x3FH. Measure current between ACP and ACN. Trigger when the current is above this threshold. 0: 1ms max <default at POR> 1: 50 ms max
	[0]	[0]	Reserved	0- Reserved

8.6.5 ProchotOption1 Register

Figure 20. ProchotOption1 Register (0x3DH)

15	14	13	12	11	10	9	8
IDCHG Comparator Threshold						IDCHG Comparator Deglitch Time	
R/W						R/W	
7	6	5	4	3	2	1	0
Reserved	PROCHOT envelop selector						
R	R/W						

LEGEND: R/W = Read/Write; R = Read only; -n = value after reset

Table 9. ProchotOption1 Register (0x3DH)

I2C 07H	I2C 06H	SMBus 0x3DH	BIT NAME	DESCRIPTION
[7:2]		[15:10]	IDCHG Comparator Threshold	6 bit, range, range 0A – 32256 mA, step 512 mA. Measure current between SRN and SRP. Trigger when the discharge current is above the threshold. Default: 16384 mA (100000)
[1:0]		[9:8]	IDCHG Comparator Deglitch Time	00: 1.6 ms 01: 100 µs <default at POR> 10: 6 ms 11: 12 ms
	[7]	[7]	Reserved	0- Reserved
	[6:0]	[6:0]	PROCHOT envelop selector	When adapter is present, the /PROCHOT function is enabled by the below bits. When adapter is removed, ICRIT, INOM, BATPRES and ACOK functions are automatically disabled in the PROCHOT profile. Comparator, IBAT and VSYS function setting are preserved. When all the bits are 0, PROCHOT function is disabled. Bit6: Independent comparator, 0: disable <default at POR> ; 1: enable Bit5: ICRIT, 0: disable; 1: enable <default at POR> Bit4: INOM, 0: disable <default at POR> ; 1: enable Bit3: IDCHG, 0: disable <default at POR> ; 1: enable Bit2: VSYS, 0: disable; 1: enable <default at POR> Bit1: BATPRES, 0: disable <default at POR> ; 1: enable (one-shot rising edge triggered) Bit0: ACOK, 0: disable <default at POR> ; 1: enable (one-shot falling edge triggered)

8.6.6 Setting the Charge Current

To set the charge current, write a 16-bit ChargeCurrent() command. With 10mΩ sense resistor, the bq2477x provides charge current range of 128mA to 8.128A, with 64mA step resolution. It is suggested to write battery voltage to MaxChargeVoltage() before programming ChargeCurrent(). When battery is absent, the host should write 0A to ChargeCurrent().

During pre-charge, the charge current is clamped at 384mA. Sending ChargeCurrent() 0mA will terminate charge. Upon POR, charge current setting is 0mA.

For 1s charging, the charge current is clamped at 384 mA when battery is below BATLOWV threshold. When battery is between BATLOWV and SYSMIN, the charging current is clamped at 2 A. When battery is above SYSMIN, the charging current follows register setting.

To program charge current in bq24773, the host has to write 2-byte command with REG0A first, followed by REG0B. No other command can be inserted in between. After the completion of REG0A and REG0B, charge current will be updated. If host writes REG0B first, the command will be ignored. If the time between write of REG0A and REG0B exceeds watchdog timer, the REG0A command will be ignored.

The SRP and SRN pins are used to sense voltage drop across R_{SR} with default value of 10mΩ. For a larger sense resistor, a larger sense voltage is given, and a higher regulation accuracy; but at the expense of higher conduction loss. A current sensing resistor value no more than 20mΩ is suggested.

A 0.1μF capacitor between SRP and SRN for differential mode filtering is recommended; a 0.1μF capacitor between SRN and ground, and an optional 0.1μF capacitor between SRP and ground for common mode filtering. Meanwhile, the capacitance on SRP should not be higher than 0.1μF in order to properly sense voltage across SRP and SRN.

Table 10. Charge Current Register with 10mΩ Sense Resistor

I2C 0BH	I2C 0AH	SMBus 0x14H	BIT NAME	DESCRIPTION
	0	0	–	Not used. Value ignored.
	1	1	–	Not used. Value ignored.
	2	2	–	Not used. Value ignored.
	3	3	–	Not used. Value ignored.
	4	4	–	Not used. Value ignored.
	5	5	–	Not used. Value ignored.
	6	6	Charge Current, DACICHG 0	0 = Adds 0mA of charger current. 1 = Adds 64mA of charger current.
	7	7	Charge Current, DACICHG 1	0 = Adds 0mA of charger current. 1 = Adds 128mA of charger current.
0		8	Charge Current, DACICHG 2	0 = Adds 0mA of charger current. 1 = Adds 256mA of charger current.
1		9	Charge Current, DACICHG 3	0 = Adds 0mA of charger current. 1 = Adds 512mA of charger current.
2		10	Charge Current, DACICHG 4	0 = Adds 0mA of charger current. 1 = Adds 1024mA of charger current.
3		11	Charge Current, DACICHG 5	0 = Adds 0mA of charger current. 1 = Adds 2048mA of charger current.
4		12	Charge Current, DACICHG 6	0 = Adds 0mA of charger current. 1 = Adds 4096mA of charger current.
5		13	–	Not used. 1 = invalid write.
6		14	–	Not used. 1 = invalid write.
7		15	–	Not used. 1 = invalid write.

8.6.7 Setting the Maximum Charge Voltage

To set the output charge regulation voltage, write a 16-bit MaxChargeVoltage() command. The bq2477x provides charge voltage range from 1.024V to 19.200V, with 16mV step resolution. Upon POR or when charge is disabled, the system is regulated at MaxChargeVoltage().

If enable charge without writing any command to MaxChargeVoltage(), the MaxChargeVoltage() is automatically changed to 4.2V/cell. If disable charge without writing any command to MaxChargeVoltage(), the MaxChargeVoltage() automatically goes back to POR value. Once writing a valid value to MaxChargeVoltage(), the register doesn't automatically change between charge enable and disable.

The BAT pin is used to sense the battery voltage for voltage regulation and should be connected as close to the battery pack positive side as possible. A decoupling capacitor of 0.1µF is recommended as close to IC as possible to decouple high frequency noise.

To program charge voltage in bq24773, the host has to write 2-byte command with REG0C first, followed by REG0D. No other command can be inserted in between. After the completion of REG0C and REG0D, charge voltage will be updated. If host writes REG0D first, the command will be ignored. If the time between write of REG0C and REG0D exceeds watchdog timer, the REG0C command will be ignored.

Table 11. Max Charge Voltage Register

I2C ODH	I2C OCH	SMBus REG 0x15H	BIT NAME	DESCRIPTION
	0	0	–	Not used. Value ignored.
	1	1	–	Not used. Value ignored.
	2	2	–	Not used. Value ignored.
	3	3	–	Not used. Value ignored.
	4	4	Charge Voltage, DACV 0	0 = Adds 0mV of charger voltage. 1 = Adds 16mV of charger voltage.
	5	5	Charge Voltage, DACV 1	0 = Adds 0mV of charger voltage. 1 = Adds 32mV of charger voltage.
	6	6	Charge Voltage, DACV 2	0 = Adds 0mV of charger voltage. 1 = Adds 64mV of charger voltage.
	7	7	Charge Voltage, DACV 3	0 = Adds 0mV of charger voltage. 1 = Adds 128mV of charger voltage.
0		8	Charge Voltage, DACV 4	0 = Adds 0mV of charger voltage. 1 = Adds 256mV of charger voltage.
1		9	Charge Voltage, DACV 5	0 = Adds 0mV of charger voltage. 1 = Adds 512mV of charger voltage.
2		10	Charge Voltage, DACV 6	0 = Adds 0mV of charger voltage. 1 = Adds 1024mV of charger voltage.
3		11	Charge Voltage, DACV 7	0 = Adds 0mV of charger voltage. 1 = Adds 2048mV of charger voltage.
4		12	Charge Voltage, DACV 8	0 = Adds 0mV of charger voltage. 1 = Adds 4096mV of charger voltage.
5		13	Charge Voltage, DACV 9	0 = Adds 0mV of charger voltage. 1 = Adds 8192mV of charger voltage.
6		14	Charge Voltage, DACV 10	0 = Adds 0mV of charger voltage. 1 = Adds 16384mV of charger voltage.
7		15	–	Not used. 1 = invalid write.

8.6.8 Setting the Minimum Charge Voltage

The device deploys Narrow VDC architecture (NVDC) with BATFET separating system from battery. When charge is enabled, and the battery is below `MinSystemVoltage()`, the system is regulated at the minimum system voltage setting. When charge is disabled, the system is regulated at `MaxChargeVoltage()`.

To set the minimum system voltage, write a 16-bit `MinSystemVoltage()` command. The bq2477x provides minimum system voltage range from 1.024V to 19.200V, with 256mV step resolution.

Table 12. Minimum System Voltage Register

I2C 0EH	SMBus 0x3EH	BIT NAME	DESCRIPTION
	0	–	Not used. Value ignored.
	1	–	Not used. Value ignored.
	2	–	Not used. Value ignored.
	3	–	Not used. Value ignored.
	4	–	Not used. Value ignored.
	5	–	Not used. Value ignored.
	6	–	Not used. Value ignored.
	7	–	Not used. Value ignored.
0	8	Minimum System Voltage, DACMINSV 0	0 = Adds 0mV of system Voltage. 1 = Adds 256mV of system Voltage.
1	9	Minimum System Voltage, DACMINSV 1	0 = Adds 0mV of system Voltage. 1 = Adds 512mV of system Voltage.
2	10	Minimum System Voltage, DACMINSV 2	0 = Adds 0mV of system Voltage. 1 = Adds 1024mV of system Voltage.
3	11	Minimum System Voltage, DACMINSV 3	0 = Adds 0mV of system Voltage. 1 = Adds 2048mV of system Voltage.
4	12	Minimum System Voltage, DACMINSV 4	0 = Adds 0mV of system Voltage. 1 = Adds 4096mV of system Voltage.
5	13	Minimum System Voltage, DACMINSV 5	0 = Adds 0mV of system Voltage. 1 = Adds 8192mV of system Voltage.
6	14	–	Not used. 1 = invalid write.
7	15	–	Not used. 1 = invalid write.

Table 13. Default MaxChargeVoltage and System Voltage

NUMBER of CELLS	MaxChargeVoltage()		MinSystemVoltage()
	Charge Enable	Charge Disable	
1S (CELL=GND)	4.192V	4.400V	3.584V
2S (CELL=FLOAT)	8.400V	9.008V	6.144V
3S/4S (CELL=High)	12.592V	13.500V	9.216V

8.6.9 Setting Input Current

Normally, input power source powers system and charges battery. With AC wall adapter output current can be regulated to save system cost.

To set the input current limit, write a 16-bit InputCurrent() command. When using a 10mΩ sense resistor, the bq2477x provides an input-current limit range of 128mA to 8.128A, with 64mA resolution. Upon POR, default input current limit is 3.2A (770) or 2.944A (773).

The ACP and ACN pins are used to sense $R_{(AC)}$ with default value of 10mΩ. However, resistors of other values can also be used. For a larger sense resistor, larger sense voltage is given, and a higher regulation accuracy; but, at the expense of higher conduction loss.

Table 14. Input Current Register using 10mΩ sense resistor

I2C 0FH	SMBus REG 0x3FH	BIT NAME	DESCRIPTION
	0	–	Not used. Value ignored.
	1	–	Not used. Value ignored.
	2	–	Not used. Value ignored.
	3	–	Not used. Value ignored.
	4	–	Not used. Value ignored.
	5	–	Not used. Value ignored.
0	6	Input Current, DACIIN 0	0 = Adds 0mA of input current. 1 = Adds 64mA of input current.
1	7	Input Current, DACIIN 1	0 = Adds 0mA of input current. 1 = Adds 128mA of input current.
2	8	Input Current, DACIIN 2	0 = Adds 0mA of input current. 1 = Adds 256mA of input current.
3	9	Input Current, DACIIN 3	0 = Adds 0mA of input current. 1 = Adds 512mA of input current.
4	10	Input Current, DACIIN 4	0 = Adds 0mA of input current. 1 = Adds 1024mA of input current.
5	11	Input Current, DACIIN 5	0 = Adds 0mA of input current. 1 = Adds 2048mA of input current.
6	12	Input Current, DACIIN 6	0 = Adds 0mA of input current. 1 = Adds 4096mA of input current.
7	13	–	Not used. 1 = invalid write.
	14	–	Not used. 1 = invalid write.
	15	–	Not used. 1 = invalid write.

9 Application and Implementation

NOTE

Information in the following applications sections is not part of the TI component specification, and TI does not warrant its accuracy or completeness. TI's customers are responsible for determining suitability of components for their purposes. Customers should validate and test their design implementation to confirm system functionality.

9.1 Application Information

The bq2477x EVM-540 evaluation module (EVM) is a complete charger module for evaluating the bq2477x. The application curves were taken using the bq24770 EVM-540. Refer to the EVM user's guide ([SLUUA03](#)) for EVM information.

9.2 Typical Application, bq24770

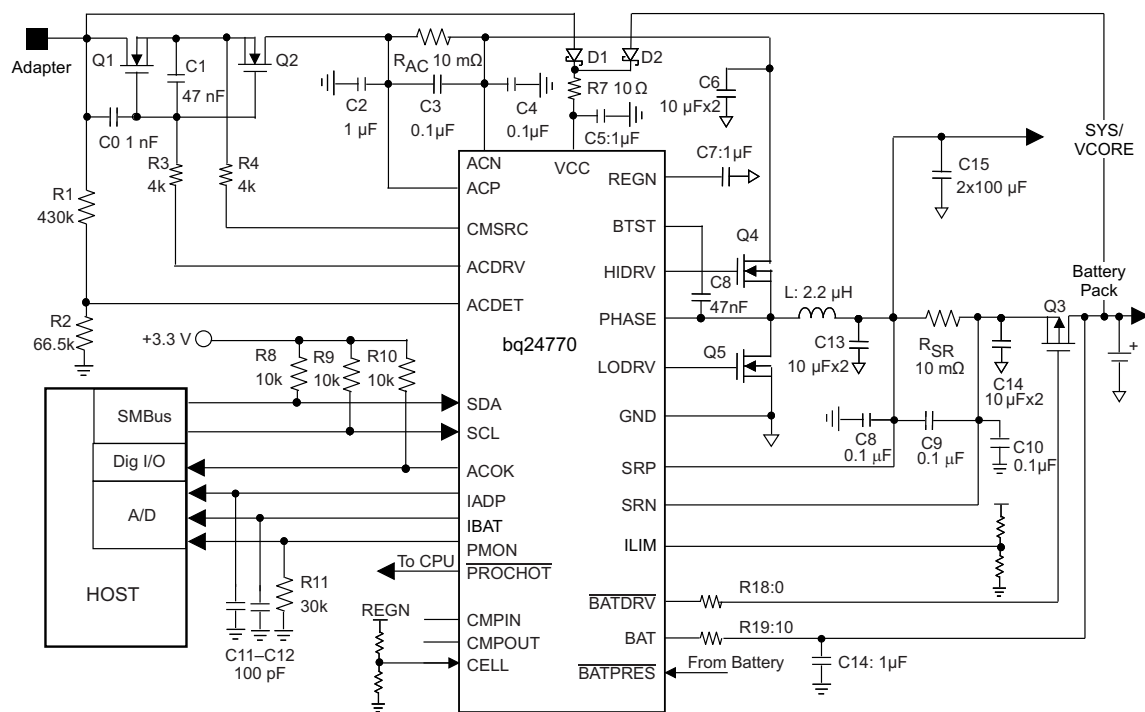

Copyright © 2016, Texas Instruments Incorporated

Figure 21. bq24770 Application Schematic

9.2.1 Design Requirements

DESIGN PARAMETER	EXAMPLE VALUE
Input Voltage ⁽¹⁾	17.7V < Adapter Voltage < 24V
Input Current Limit ⁽¹⁾	3.2A for 65W adapter
Battery Charge Voltage ⁽²⁾	8400mV for 2s battery
Battery Charge Current ⁽²⁾	4096mA for 3s battery
Minimum System Voltage ⁽²⁾	6144mA for 2s battery

(1) Refer to adapter specification for settings for Input Voltage and Input Current Limit.

(2) Refer to battery specification for settings.

9.2.2 Detailed Design Procedure

The parameters are configurable using the evaluation software.

The simplified application circuit (see Figure 21) shows the minimum capacitance requirements for each pin. Inductor, capacitor, and MOSFET selection are explained in the rest of this section. Refer to the EVM user's guide (SLUUAO3) for the full application schematic.

9.2.2.1 Reverse Input Voltage Protection

Q6, R12, and R13 in Figure 22 give system and IC protection from reversed adapter voltage. In normal operation, Q6 is turned off by negative Vgs. When adapter voltage is reversed, Q6 Vgs is positive. As a result, Q6 turns on to short gate and source of Q2 so that Q2 is off. Q2 body diode blocks negative voltage to system. However, CMSRC and ACDRV pins need R3 and R4 to limit the current due to the ESD diode of these pins when turned on. Q6 must have low Vgs threshold voltage and low Qgs gate charge so it turns on before Q2 turns on. R3 and R4 must have enough power rating for the power dissipation when the ESD diode is on. If Q1 is replaced by Schottky diode for reverse adapter voltage protection, no extra small MOSFET and resistors are needed.

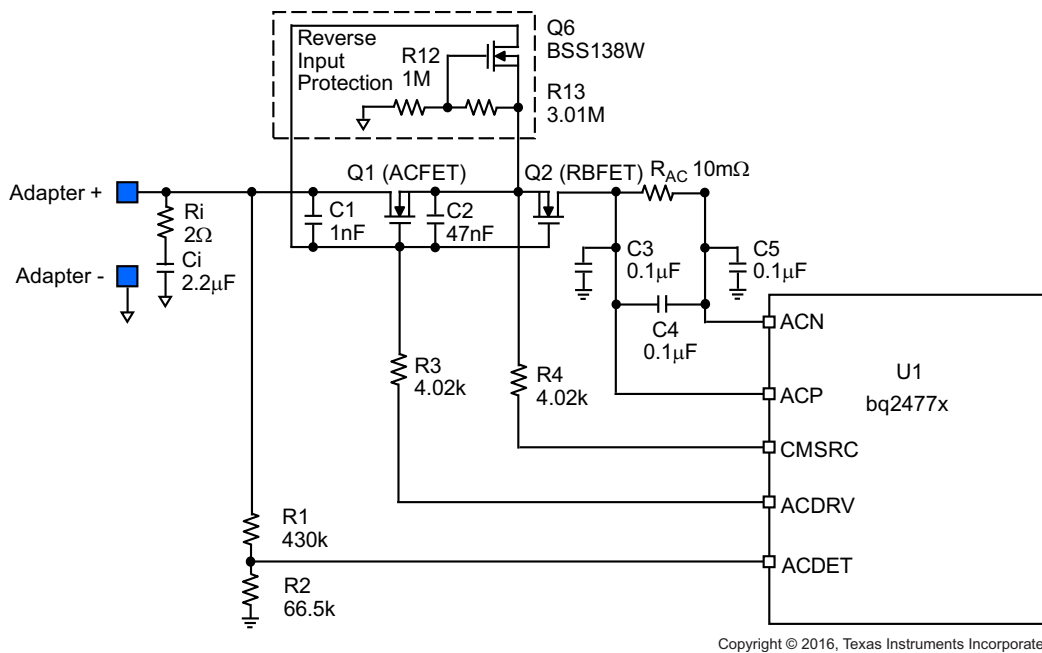

Figure 22. Reverse Input Voltage Protection Circuit

9.2.2.2 Inductor Selection

The bq2477x has three selectable fixed switching frequency. Higher switching frequency allows the use of smaller inductor and capacitor values. Inductor saturation current should be higher than the charging current (I_{CHG}) plus half the ripple current (I_{RIPPLE}):

$$I_{SAT} \geq I_{CHG} + (1/2) I_{RIPPLE} \quad (2)$$

The inductor ripple current depends on input voltage (V_{IN}), duty cycle ($D = V_{OUT}/V_{IN}$), switching frequency (f_S) and inductance (L):

$$I_{RIPPLE} = \frac{V_{IN} \times D \times (1 - D)}{f_S \times L} \quad (3)$$

The maximum inductor ripple current happens with $D = 0.5$ or close to 0.5. For example, the battery charging voltage range is from 9V to 12.6V for 3-cell battery pack. For 20 V adapter voltage, 10 V battery voltage gives the maximum inductor ripple current. Another example is 4-cell battery, the battery voltage range is from 12 V to 16.8 V, and 12 V battery voltage gives the maximum inductor ripple current.

Usually inductor ripple is designed in the range of (20-40%) maximum charging current as a trade-off between inductor size and efficiency for a practical design.

9.2.2.3 Input Capacitor

Input capacitor should have enough ripple current rating to absorb input switching ripple current. The worst case RMS ripple current is half of the charging current when duty cycle is 0.5. If the converter does not operate at 50% duty cycle, then the worst case capacitor RMS current occurs where the duty cycle is closest to 50% and can be estimated by [Equation 4](#):

$$I_{CIN} = I_{CHG} \times \sqrt{D \times (1 - D)} \quad (4)$$

Low ESR ceramic capacitor such as X7R or X5R is preferred for input decoupling capacitor and should be placed to the drain of the high side MOSFET and source of the low side MOSFET as close as possible. Voltage rating of the capacitor must be higher than normal input voltage level. 25 V rating or higher capacitor is preferred for 19-20 V input voltage. 10-20 μ F capacitance is suggested for typical of 3-4 A charging current.

Ceramic capacitors show a dc-bias effect. This effect reduces the effective capacitance when a dc-bias voltage is applied across a ceramic capacitor, as on the input capacitor of a charger. The effect may lead to a significant capacitance drop, especially for high input voltages and small capacitor packages. See the manufacturer's datasheet about the performance with a dc bias voltage applied. It may be necessary to choose a higher voltage rating or nominal capacitance value in order to get the required value at the operating point.

9.2.2.4 Output Capacitor

Output capacitor also should have enough ripple current rating to absorb output switching ripple current. The output capacitor RMS current is given:

$$I_{COUT} = \frac{I_{RIPPLE}}{2 \times \sqrt{3}} \approx 0.29 \times I_{RIPPLE} \quad (5)$$

The bq2477x has internal loop compensator. To get good loop stability, the resonant frequency of the output inductor and output capacitor should be designed between 10 kHz and 20 kHz. The preferred ceramic capacitor is 25V X7R or X5R for output capacitor. 10-20 μ F capacitance is suggested for a typical of 3-4A charging current. Place the capacitors after charging current sensing resistor to get the best charge current regulation accuracy.

Ceramic capacitors show a dc-bias effect. This effect reduces the effective capacitance when a dc-bias voltage is applied across a ceramic capacitor, as on the output capacitor of a charger. The effect may lead to a significant capacitance drop, especially for high output voltages and small capacitor packages. See the manufacturer's data sheet about the performance with a dc bias voltage applied. It may be necessary to choose a higher voltage rating or nominal capacitance value in order to get the required value at the operating point.

9.2.2.5 Power MOSFETs Selection

Two external N-channel MOSFETs are used for a synchronous switching battery charger. The gate drivers are internally integrated into the IC with 6V of gate drive voltage. 30 V or higher voltage rating MOSFETs are preferred for 19-20 V input voltage.

Figure-of-merit (FOM) is usually used for selecting proper MOSFET based on a tradeoff between the conduction loss and switching loss. For the top side MOSFET, FOM is defined as the product of a MOSFET's on-resistance, $R_{DS(ON)}$, and the gate-to-drain charge, Q_{GD} . For the bottom side MOSFET, FOM is defined as the product of the MOSFET's on-resistance, $R_{DS(ON)}$, and the total gate charge, Q_G .

$$FOM_{top} = R_{DS(on)} \times Q_{GD}; FOM_{bottom} = R_{DS(on)} \times Q_G \quad (6)$$

The lower the FOM value, the lower the total power loss. Usually lower $R_{DS(ON)}$ has higher cost with the same package size.

The top-side MOSFET loss includes conduction loss and switching loss. It is a function of duty cycle ($D=V_{OUT}/V_{IN}$), charging current (I_{CHG}), MOSFET's on-resistance ($R_{DS(ON)}$), input voltage (V_{IN}), switching frequency (f_s), turn on time (t_{on}) and turn off time (t_{off}):

$$P_{top} = D \times I_{CHG}^2 \times R_{DS(on)} + \frac{1}{2} \times V_{IN} \times I_{CHG} \times (t_{on} + t_{off}) \times f_s \quad (7)$$

The first item represents the conduction loss. Usually MOSFET $R_{DS(ON)}$ increases by 50% with 100°C junction temperature rise. The second term represents the switching loss. The MOSFET turn-on and turn-off times are given by:

$$t_{on} = \frac{Q_{SW}}{I_{on}}, \quad t_{off} = \frac{Q_{SW}}{I_{off}} \quad (8)$$

where Q_{SW} is the switching charge, I_{on} is the turn-on gate driving current and I_{off} is the turn-off gate driving current. If the switching charge is not given in MOSFET datasheet, it can be estimated by gate-to-drain charge (Q_{GD}) and gate-to-source charge (Q_{GS}):

$$Q_{SW} = Q_{GD} + \frac{1}{2} \times Q_{GS} \quad (9)$$

Gate driving current can be estimated by REGN voltage (V_{REGN}), MOSFET plateau voltage (V_{plt}), total turn-on gate resistance (R_{on}) and turn-off gate resistance (R_{off}) of the gate driver:

$$I_{on} = \frac{V_{REGN} - V_{plt}}{R_{on}}, \quad I_{off} = \frac{V_{plt}}{R_{off}} \quad (10)$$

The conduction loss of the bottom-side MOSFET is calculated with the following equation when it operates in synchronous continuous conduction mode:

$$P_{bottom} = (1 - D) \times I_{CHG}^2 \times R_{DS(on)} \quad (11)$$

When charger operates in non-synchronous mode, the bottom-side MOSFET is off. As a result all the freewheeling current goes through the body-diode of the bottom-side MOSFET. The body diode power loss depends on its forward voltage drop (V_F), non-synchronous mode charging current ($I_{NONSYNC}$), and duty cycle (D).

$$P_D = V_F \times I_{NONSYNC} \times (1 - D) \quad (12)$$

The maximum charging current in non-synchronous mode can be up to 0.25 A for a 10 mΩ charging current sensing resistor or 0.5 A if battery voltage is below 2.5 V. The minimum duty cycle happens at lowest battery voltage. Choose the bottom-side MOSFET with either an internal Schottky or body diode capable of carrying the maximum non-synchronous mode charging current.

9.2.2.6 Input Filter Design

During adapter hot plug-in, the parasitic inductance and input capacitor from the adapter cable form a second order system. The voltage spike at VCC pin maybe beyond IC maximum voltage rating and damage IC. The input filter must be carefully designed and tested to prevent over voltage event on VCC pin.

There are several methods to damping or limit the over voltage spike during adapter hot plug-in. An electrolytic capacitor with high ESR as an input capacitor can damp the over voltage spike well below the IC maximum pin voltage rating. A high current capability TVS Zener diode can also limit the over voltage level to an IC safe level. However these two solutions may not have low cost or small size.

A cost effective and small size solution is shown in [Figure 23](#). The R1 and C1 are composed of a damping RC network to damp the hot plug-in oscillation. As a result the over voltage spike is limited to a safe level. D1 is used for reverse voltage protection for VCC pin. C2 is VCC pin decoupling capacitor and it should be place to VCC pin as close as possible. C2 value should be less than C1 value so R1 can dominant the equivalent ESR value to get enough damping effect. R2 is used to limit inrush current of D1 to prevent D1 getting damage when adapter hot plug-in. R2 and C2 should have 10 μs time constant to limit the dv/dt on VCC pin to reduce inrush current when adapter hot plug in. R1 has high inrush current. R1 package must be sized enough to handle inrush current power loss according to resistor manufacturer's data sheet. The filter components value always need to be verified with real application and minor adjustments may need to fit in the real application circuit.

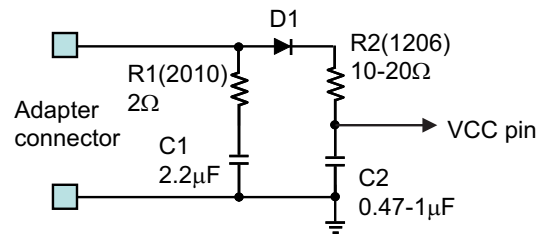

Figure 23. Input Filter

9.2.3 Application Curves

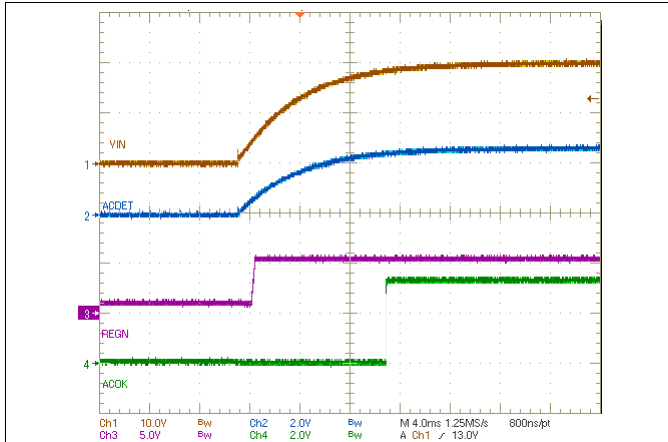

Figure 24. VIN, ACDET, REGN, and ACOK During Power Up

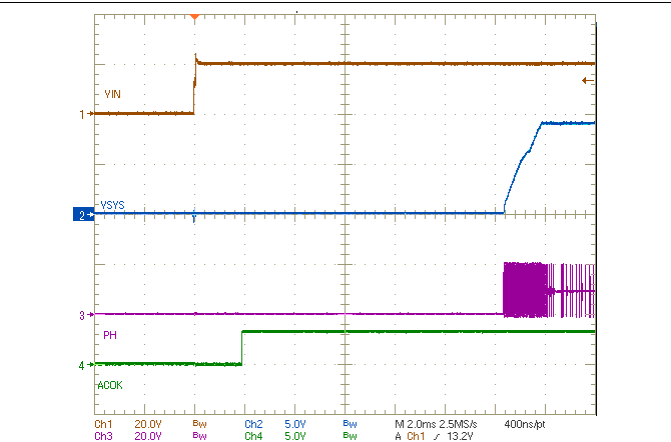

Figure 25. VIN, VSYS, PH and ACOK During Power Up

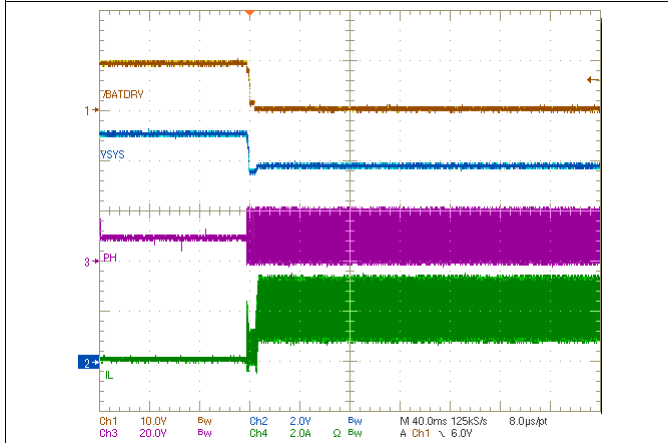

Figure 26. Charge Enable From 0x14()

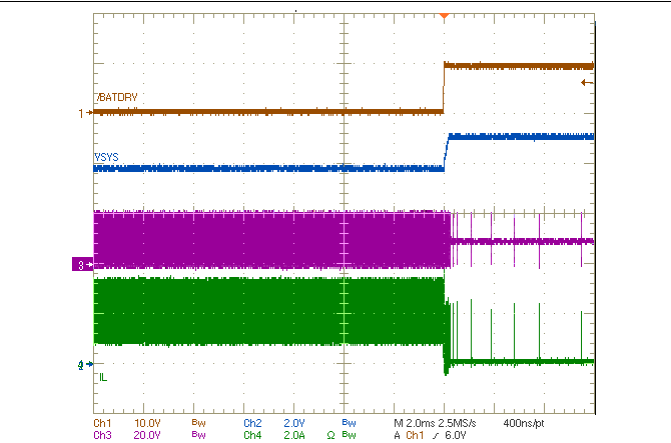
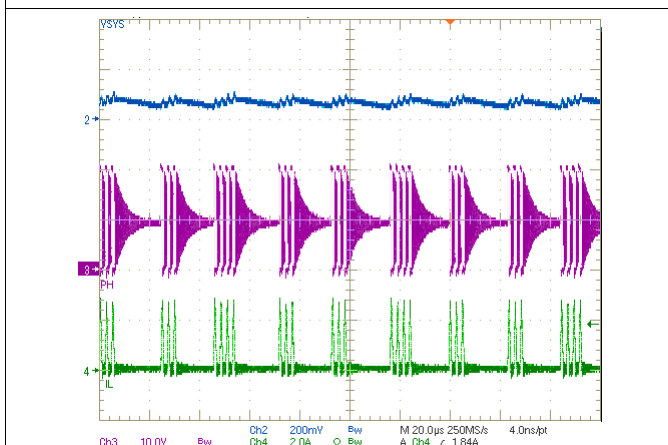
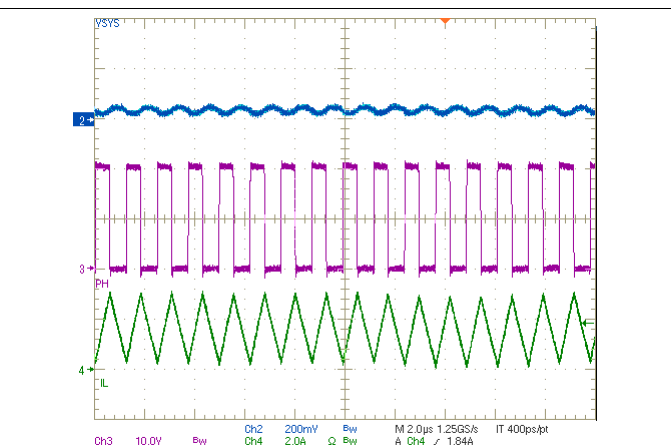

Figure 27. Current Disabled



$V_{IN} = 19.5\text{ V}$ $I_{(SYS)} = 200\text{ mA}$ CELL = Float

Figure 28. PFM Switching



$V_{IN} = 19.5\text{ V}$ $I_{(SYS)} = 1.5\text{ A}$ CELL = Float

Figure 29. PWM Switching

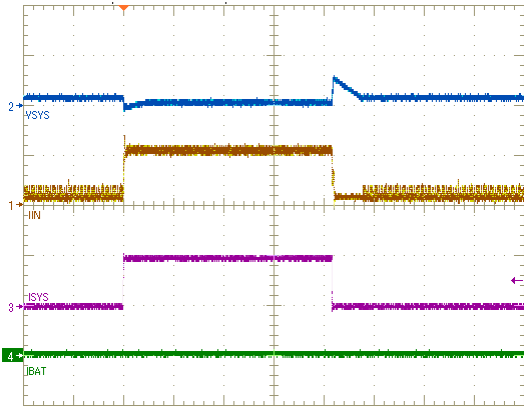

$V_{IN} = 19.5\text{ V}$ CELL = Float

Figure 30. Transient Response, Charge Disabled, Not in DPM

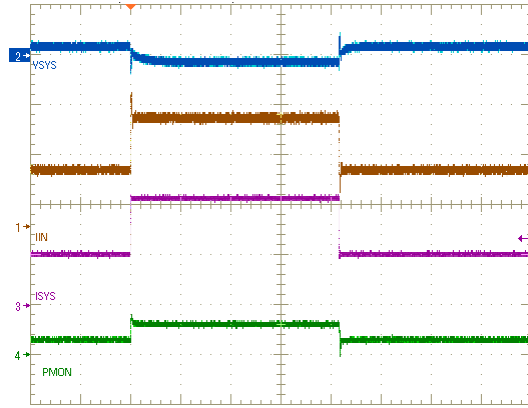

$V_{IN} = 19.5\text{ V}$ CELL = Float

Figure 31. Transient Response, Charge Disabled, In DPM

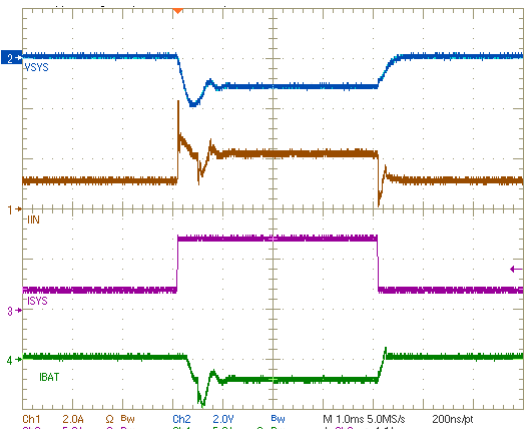

$V_{IN} = 19.5\text{ V}$ CELL = Float

Figure 32. Transient Response, Charge Disabled, In Supplement Mode

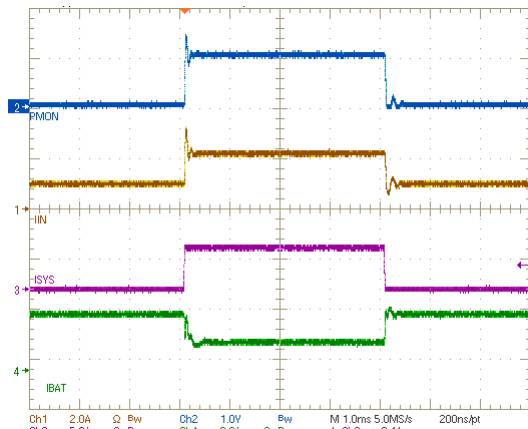

$V_{IN} = 19.5\text{ V}$ CELL = Float $V_{BAT} = 7.5\text{ V}$

Figure 33. Transient Response, Charge Enable, In DPM

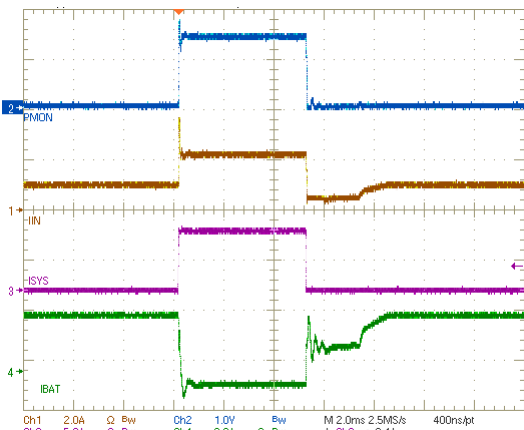

$V_{IN} = 19.5\text{ V}$ CELL = Float $V_{BAT} = 7.5\text{ V}$

Figure 34. Transient Response, Charge Enable, In Supplement Mode

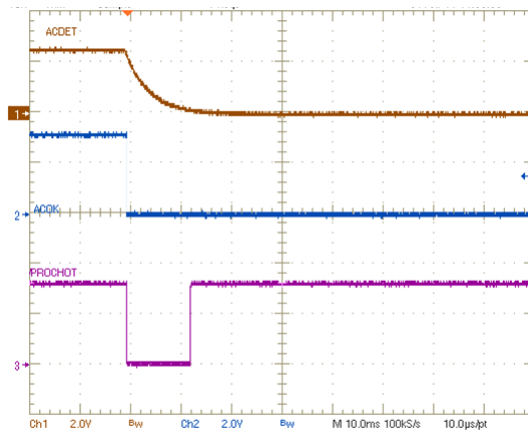

IDPM 3072 mA ICHG 2432mA $V_{BAT} = 11\text{ V}$
ICRIT 150% × IDPM

Figure 35. $\overline{\text{PROCHOT}}$ From Adapter Removal

9.2.4 Typical Application, bq24773

The bq2477xEVM-540 evaluation module (EVM) is a complete charger module for evaluating the bq2477x. The application curves were taken using the bq24770EVM-540. Refer to the EVM user's guide (SLUUA03) for EVM information.

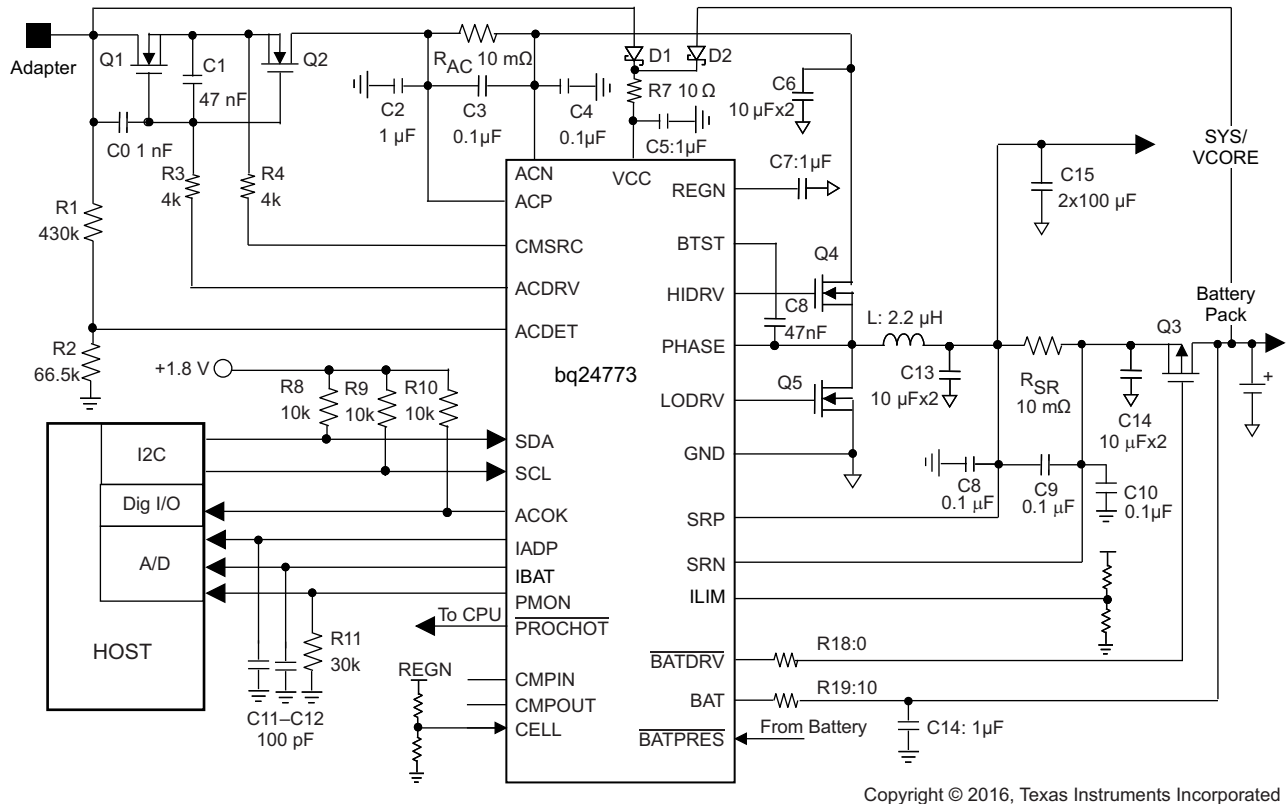

Figure 36. bq24773 Typical Schematic

9.2.4.1 Design Requirements

Refer to [Typical Application, bq24770](#) for the Design Requirements.

9.2.4.2 Detailed Design Procedure

Refer to [Typical Application, bq24770](#) for the Detailed Design Procedure.

9.2.4.3 Application Curves

Refer to [Typical Application, bq24770](#) for the Application Curves.

10 Power Supply Recommendations

When adapter is attached, and ACOK goes HIGH, the system is connected to adapter through ACFET/RBFET. An external resistor voltage divider attenuates the adapter voltage before it goes to ACDET. The adapter detect threshold should typically be programmed to a value greater than the maximum battery voltage, but lower than the IC maximum allowed input voltage (ACOV_P) and system maximum allowed voltage.

When adapter is removed, the system is connected to battery through BATFET. Typically the battery depletion threshold should be greater than the minimum system voltage so that the battery capacity can be fully utilized for maximum battery life.

11 Layout

11.1 Layout Guidelines

The switching node rise and fall times should be minimized for minimum switching loss. Proper layout of the components to minimize high frequency current path loop (see [Figure 37](#)) is important to prevent electrical and magnetic field radiation and high frequency resonant problems. Layout of the PCB according to this specific order is essential.

- Place input capacitor as close as possible to switching MOSFET's supply and ground connections and use shortest copper trace connection. These parts should be placed on the same layer of PCB instead of on different layers and using vias to make this connection.
- The IC should be placed close to the switching MOSFET's gate pins and keep the gate drive signal traces short for a clean MOSFET drive. The IC can be placed on the other side of the PCB of switching MOSFETs.
- Place inductor input pin to switching MOSFET's output pin as close as possible. Minimize the copper area of this trace to lower electrical and magnetic field radiation but make the trace wide enough to carry the charging current. Do not use multiple layers in parallel for this connection. Minimize parasitic capacitance from this area to any other trace or plane.
- The charging current sensing resistor should be placed right next to the inductor output. Route the sense leads connected across the sensing resistor back to the IC in same layer, close to each other (minimize loop area) and do not route the sense leads through a high-current path (see [Figure 38](#) for Kelvin connection for best current accuracy). Place decoupling capacitor on these traces next to the IC
- Place output capacitor next to the sensing resistor output and ground
- Output capacitor ground connections need to be tied to the same copper that connects to the input capacitor ground before connecting to system ground.
- Use single ground connection to tie charger power ground to charger analog ground. Just beneath the IC use analog ground copper pour but avoid power pins to reduce inductive and capacitive noise coupling
- Route analog ground separately from power ground. Connect analog ground and connect power ground separately. Connect analog ground and power ground together using power pad as the single ground connection point. Or using a 0Ω resistor to tie analog ground to power ground (power pad should tie to analog ground in this case if possible).
- Decoupling capacitors should be placed next to the IC pins and make trace connection as short as possible
- It is critical that the exposed power pad on the backside of the IC package be soldered to the PCB ground. Ensure that there are sufficient thermal vias directly under the IC, connecting to the ground plane on the other layers.
- The via size and number should be enough for a given current path.

See the EVM design for the recommended component placement with trace and via locations. For the WQFN information, See [SCBA017](#) and [SLUA271](#).

11.2 Layout Example

11.2.1 Layout Consideration of Current Path

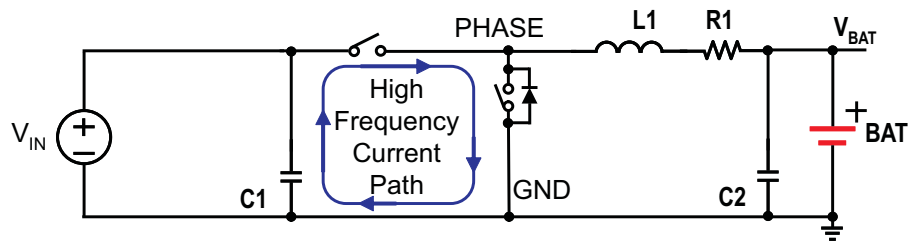

Figure 37. High Frequency Current Path

11.2.2 Layout Consideration of Short Circuit Protection

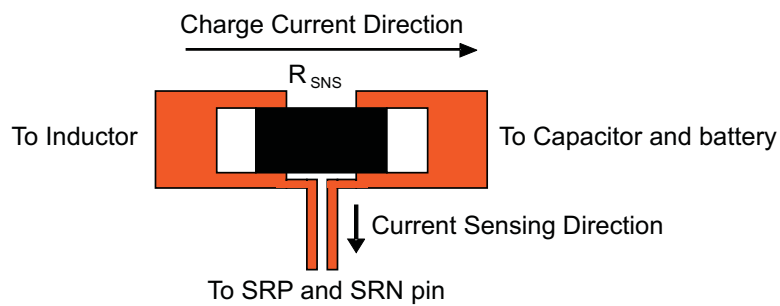

Figure 38. Sensing Resistor PCB Layout

12 Device and Documentation Support

12.1 Related Links

The table below lists quick access links. Categories include technical documents, support and community resources, tools and software, and quick access to sample or buy.

Table 15. Related Links

PARTS	PRODUCT FOLDER	SAMPLE & BUY	TECHNICAL DOCUMENTS	TOOLS & SOFTWARE	SUPPORT & COMMUNITY
bq24770	Click here	Click here	Click here	Click here	Click here
bq24773	Click here	Click here	Click here	Click here	Click here

12.2 Receiving Notification of Documentation Updates

To receive notification of documentation updates, navigate to the device product folder on ti.com. In the upper right corner, click on *Alert me* to register and receive a weekly digest of any product information that has changed. For change details, review the revision history included in any revised document.

12.3 Community Resources

The following links connect to TI community resources. Linked contents are provided "AS IS" by the respective contributors. They do not constitute TI specifications and do not necessarily reflect TI's views; see TI's [Terms of Use](#).

TI E2E™ Online Community *TI's Engineer-to-Engineer (E2E) Community*. Created to foster collaboration among engineers. At e2e.ti.com, you can ask questions, share knowledge, explore ideas and help solve problems with fellow engineers.

Design Support *TI's Design Support* Quickly find helpful E2E forums along with design support tools and contact information for technical support.

12.4 Trademarks

E2E is a trademark of Texas Instruments.
All other trademarks are the property of their respective owners.

12.5 Electrostatic Discharge Caution



These devices have limited built-in ESD protection. The leads should be shorted together or the device placed in conductive foam during storage or handling to prevent electrostatic damage to the MOS gates.

12.6 Glossary

[SLYZ022](#) — *TI Glossary*.

This glossary lists and explains terms, acronyms, and definitions.

13 Mechanical, Packaging, and Orderable Information

The following pages include mechanical, packaging, and orderable information. This information is the most current data available for the designated devices. This data is subject to change without notice and revision of this document. For browser-based versions of this data sheet, refer to the left-hand navigation.

PACKAGING INFORMATION

Orderable Device	Status (1)	Package Type	Package Drawing	Pins	Package Qty	Eco Plan (2)	Lead/Ball Finish (6)	MSL Peak Temp (3)	Op Temp (°C)	Device Marking (4/5)	Samples
BQ24770RUYR	ACTIVE	WQFN	RUY	28	3000	Green (RoHS & no Sb/Br)	CU NIPDAU	Level-2-260C-1 YEAR	-40 to 85	BQ 24770	Samples
BQ24770RUYT	ACTIVE	WQFN	RUY	28	250	Green (RoHS & no Sb/Br)	CU NIPDAU	Level-2-260C-1 YEAR	-40 to 85	BQ 24770	Samples
BQ24773RUYR	ACTIVE	WQFN	RUY	28	3000	Green (RoHS & no Sb/Br)	CU NIPDAU	Level-2-260C-1 YEAR	-40 to 85	BQ 24773	Samples
BQ24773RUYT	ACTIVE	WQFN	RUY	28	250	Green (RoHS & no Sb/Br)	CU NIPDAU	Level-2-260C-1 YEAR	-40 to 85	BQ 24773	Samples

(1) The marketing status values are defined as follows:

ACTIVE: Product device recommended for new designs.

LIFEBUY: TI has announced that the device will be discontinued, and a lifetime-buy period is in effect.

NRND: Not recommended for new designs. Device is in production to support existing customers, but TI does not recommend using this part in a new design.

PREVIEW: Device has been announced but is not in production. Samples may or may not be available.

OBSOLETE: TI has discontinued the production of the device.

(2) Eco Plan - The planned eco-friendly classification: Pb-Free (RoHS), Pb-Free (RoHS Exempt), or Green (RoHS & no Sb/Br) - please check <http://www.ti.com/productcontent> for the latest availability information and additional product content details.

TBD: The Pb-Free/Green conversion plan has not been defined.

Pb-Free (RoHS): TI's terms "Lead-Free" or "Pb-Free" mean semiconductor products that are compatible with the current RoHS requirements for all 6 substances, including the requirement that lead not exceed 0.1% by weight in homogeneous materials. Where designed to be soldered at high temperatures, TI Pb-Free products are suitable for use in specified lead-free processes.

Pb-Free (RoHS Exempt): This component has a RoHS exemption for either 1) lead-based flip-chip solder bumps used between the die and package, or 2) lead-based die adhesive used between the die and leadframe. The component is otherwise considered Pb-Free (RoHS compatible) as defined above.

Green (RoHS & no Sb/Br): TI defines "Green" to mean Pb-Free (RoHS compatible), and free of Bromine (Br) and Antimony (Sb) based flame retardants (Br or Sb do not exceed 0.1% by weight in homogeneous material)

(3) MSL, Peak Temp. - The Moisture Sensitivity Level rating according to the JEDEC industry standard classifications, and peak solder temperature.

(4) There may be additional marking, which relates to the logo, the lot trace code information, or the environmental category on the device.

(5) Multiple Device Markings will be inside parentheses. Only one Device Marking contained in parentheses and separated by a "~" will appear on a device. If a line is indented then it is a continuation of the previous line and the two combined represent the entire Device Marking for that device.

(6) Lead/Ball Finish - Orderable Devices may have multiple material finish options. Finish options are separated by a vertical ruled line. Lead/Ball Finish values may wrap to two lines if the finish value exceeds the maximum column width.

Important Information and Disclaimer: The information provided on this page represents TI's knowledge and belief as of the date that it is provided. TI bases its knowledge and belief on information provided by third parties, and makes no representation or warranty as to the accuracy of such information. Efforts are underway to better integrate information from third parties. TI has taken and continues to take reasonable steps to provide representative and accurate information but may not have conducted destructive testing or chemical analysis on incoming materials and chemicals. TI and TI suppliers consider certain information to be proprietary, and thus CAS numbers and other limited information may not be available for release.

In no event shall TI's liability arising out of such information exceed the total purchase price of the TI part(s) at issue in this document sold by TI to Customer on an annual basis.

TAPE AND REEL INFORMATION

QUADRANT ASSIGNMENTS FOR PIN 1 ORIENTATION IN TAPE

*All dimensions are nominal

Device	Package Type	Package Drawing	Pins	SPQ	Reel Diameter (mm)	Reel Width W1 (mm)	A0 (mm)	B0 (mm)	K0 (mm)	P1 (mm)	W (mm)	Pin1 Quadrant
BQ24770RUYR	WQFN	RUY	28	3000	330.0	12.4	4.25	4.25	1.15	8.0	12.0	Q2
BQ24770RUYT	WQFN	RUY	28	250	180.0	12.4	4.25	4.25	1.15	8.0	12.0	Q2
BQ24773RUYR	WQFN	RUY	28	3000	330.0	12.4	4.25	4.25	1.15	8.0	12.0	Q2
BQ24773RUYT	WQFN	RUY	28	250	180.0	12.4	4.25	4.25	1.15	8.0	12.0	Q2

TAPE AND REEL BOX DIMENSIONS

*All dimensions are nominal

Device	Package Type	Package Drawing	Pins	SPQ	Length (mm)	Width (mm)	Height (mm)
BQ24770RUYR	WQFN	RUY	28	3000	367.0	367.0	35.0
BQ24770RUYT	WQFN	RUY	28	250	210.0	185.0	35.0
BQ24773RUYR	WQFN	RUY	28	3000	367.0	367.0	35.0
BQ24773RUYT	WQFN	RUY	28	250	210.0	185.0	35.0

RUY (S-PWQFN-N28)

PLASTIC QUAD FLATPACK NO-LEAD

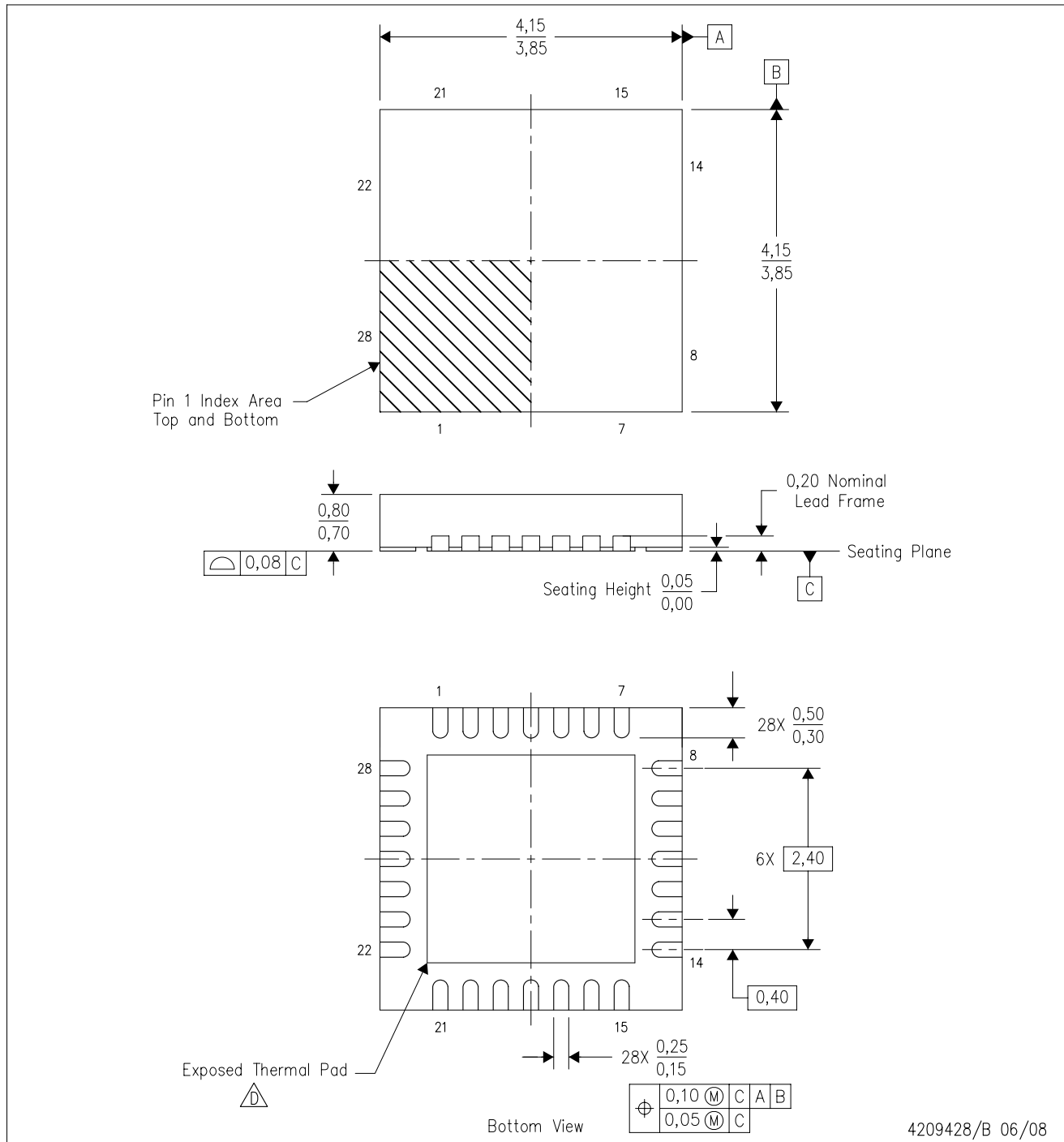

4209428/B 06/08

- NOTES:
- A. All linear dimensions are in millimeters. Dimensioning and tolerancing per ASME Y14.5M-1994.
 - B. This drawing is subject to change without notice.
 - C. QFN (Quad Flatpack No-Lead) package configuration.
 -  The package thermal pad must be soldered to the board for thermal and mechanical performance. See the Product Data Sheet for details regarding the exposed thermal pad dimensions.

THERMAL PAD MECHANICAL DATA

RUY (S-PWQFN-N28)

PLASTIC QUAD FLATPACK NO-LEAD

THERMAL INFORMATION

This package incorporates an exposed thermal pad that is designed to be attached directly to an external heatsink. The thermal pad must be soldered directly to the printed circuit board (PCB). After soldering, the PCB can be used as a heatsink. In addition, through the use of thermal vias, the thermal pad can be attached directly to the appropriate copper plane shown in the electrical schematic for the device, or alternatively, can be attached to a special heatsink structure designed into the PCB. This design optimizes the heat transfer from the integrated circuit (IC).

For information on the Quad Flatpack No-Lead (QFN) package and its advantages, refer to Application Report, QFN/SON PCB Attachment, Texas Instruments Literature No. SLUA271. This document is available at www.ti.com.

The exposed thermal pad dimensions for this package are shown in the following illustration.

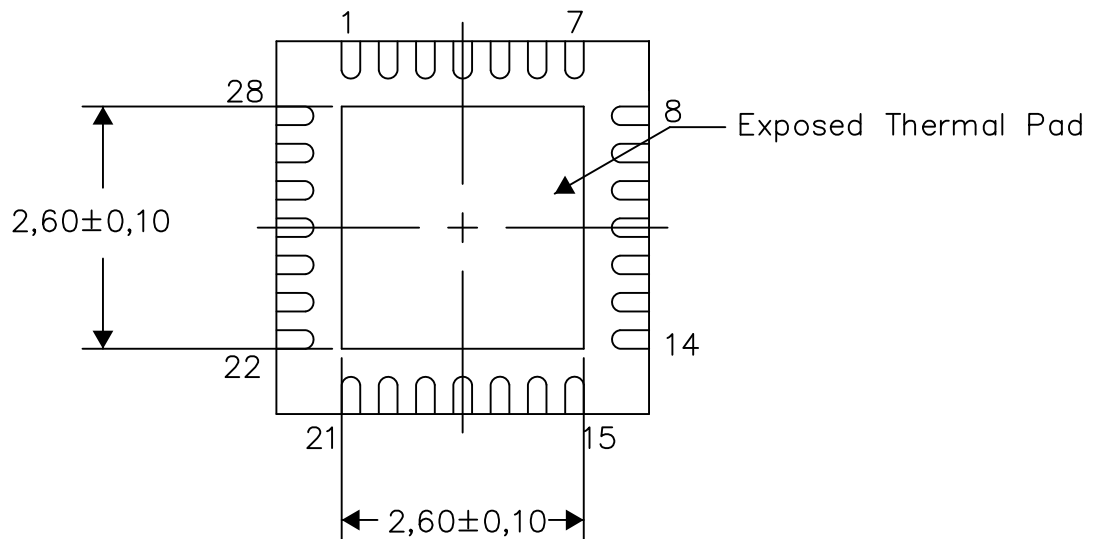

Bottom View

Exposed Thermal Pad Dimensions

4209490/F 07/15

NOTE: All linear dimensions are in millimeters

IMPORTANT NOTICE

Texas Instruments Incorporated (TI) reserves the right to make corrections, enhancements, improvements and other changes to its semiconductor products and services per JESD46, latest issue, and to discontinue any product or service per JESD48, latest issue. Buyers should obtain the latest relevant information before placing orders and should verify that such information is current and complete.

TI's published terms of sale for semiconductor products (<http://www.ti.com/sc/docs/stdterms.htm>) apply to the sale of packaged integrated circuit products that TI has qualified and released to market. Additional terms may apply to the use or sale of other types of TI products and services.

Reproduction of significant portions of TI information in TI data sheets is permissible only if reproduction is without alteration and is accompanied by all associated warranties, conditions, limitations, and notices. TI is not responsible or liable for such reproduced documentation. Information of third parties may be subject to additional restrictions. Resale of TI products or services with statements different from or beyond the parameters stated by TI for that product or service voids all express and any implied warranties for the associated TI product or service and is an unfair and deceptive business practice. TI is not responsible or liable for any such statements.

Buyers and others who are developing systems that incorporate TI products (collectively, "Designers") understand and agree that Designers remain responsible for using their independent analysis, evaluation and judgment in designing their applications and that Designers have full and exclusive responsibility to assure the safety of Designers' applications and compliance of their applications (and of all TI products used in or for Designers' applications) with all applicable regulations, laws and other applicable requirements. Designer represents that, with respect to their applications, Designer has all the necessary expertise to create and implement safeguards that (1) anticipate dangerous consequences of failures, (2) monitor failures and their consequences, and (3) lessen the likelihood of failures that might cause harm and take appropriate actions. Designer agrees that prior to using or distributing any applications that include TI products, Designer will thoroughly test such applications and the functionality of such TI products as used in such applications.

TI's provision of technical, application or other design advice, quality characterization, reliability data or other services or information, including, but not limited to, reference designs and materials relating to evaluation modules, (collectively, "TI Resources") are intended to assist designers who are developing applications that incorporate TI products; by downloading, accessing or using TI Resources in any way, Designer (individually or, if Designer is acting on behalf of a company, Designer's company) agrees to use any particular TI Resource solely for this purpose and subject to the terms of this Notice.

TI's provision of TI Resources does not expand or otherwise alter TI's applicable published warranties or warranty disclaimers for TI products, and no additional obligations or liabilities arise from TI providing such TI Resources. TI reserves the right to make corrections, enhancements, improvements and other changes to its TI Resources. TI has not conducted any testing other than that specifically described in the published documentation for a particular TI Resource.

Designer is authorized to use, copy and modify any individual TI Resource only in connection with the development of applications that include the TI product(s) identified in such TI Resource. NO OTHER LICENSE, EXPRESS OR IMPLIED, BY ESTOPPEL OR OTHERWISE TO ANY OTHER TI INTELLECTUAL PROPERTY RIGHT, AND NO LICENSE TO ANY TECHNOLOGY OR INTELLECTUAL PROPERTY RIGHT OF TI OR ANY THIRD PARTY IS GRANTED HEREIN, including but not limited to any patent right, copyright, mask work right, or other intellectual property right relating to any combination, machine, or process in which TI products or services are used. Information regarding or referencing third-party products or services does not constitute a license to use such products or services, or a warranty or endorsement thereof. Use of TI Resources may require a license from a third party under the patents or other intellectual property of the third party, or a license from TI under the patents or other intellectual property of TI.

TI RESOURCES ARE PROVIDED "AS IS" AND WITH ALL FAULTS. TI DISCLAIMS ALL OTHER WARRANTIES OR REPRESENTATIONS, EXPRESS OR IMPLIED, REGARDING RESOURCES OR USE THEREOF, INCLUDING BUT NOT LIMITED TO ACCURACY OR COMPLETENESS, TITLE, ANY EPIDEMIC FAILURE WARRANTY AND ANY IMPLIED WARRANTIES OF MERCHANTABILITY, FITNESS FOR A PARTICULAR PURPOSE, AND NON-INFRINGEMENT OF ANY THIRD PARTY INTELLECTUAL PROPERTY RIGHTS. TI SHALL NOT BE LIABLE FOR AND SHALL NOT DEFEND OR INDEMNIFY DESIGNER AGAINST ANY CLAIM, INCLUDING BUT NOT LIMITED TO ANY INFRINGEMENT CLAIM THAT RELATES TO OR IS BASED ON ANY COMBINATION OF PRODUCTS EVEN IF DESCRIBED IN TI RESOURCES OR OTHERWISE. IN NO EVENT SHALL TI BE LIABLE FOR ANY ACTUAL, DIRECT, SPECIAL, COLLATERAL, INDIRECT, PUNITIVE, INCIDENTAL, CONSEQUENTIAL OR EXEMPLARY DAMAGES IN CONNECTION WITH OR ARISING OUT OF TI RESOURCES OR USE THEREOF, AND REGARDLESS OF WHETHER TI HAS BEEN ADVISED OF THE POSSIBILITY OF SUCH DAMAGES.

Unless TI has explicitly designated an individual product as meeting the requirements of a particular industry standard (e.g., ISO/TS 16949 and ISO 26262), TI is not responsible for any failure to meet such industry standard requirements.

Where TI specifically promotes products as facilitating functional safety or as compliant with industry functional safety standards, such products are intended to help enable customers to design and create their own applications that meet applicable functional safety standards and requirements. Using products in an application does not by itself establish any safety features in the application. Designers must ensure compliance with safety-related requirements and standards applicable to their applications. Designer may not use any TI products in life-critical medical equipment unless authorized officers of the parties have executed a special contract specifically governing such use. Life-critical medical equipment is medical equipment where failure of such equipment would cause serious bodily injury or death (e.g., life support, pacemakers, defibrillators, heart pumps, neurostimulators, and implantables). Such equipment includes, without limitation, all medical devices identified by the U.S. Food and Drug Administration as Class III devices and equivalent classifications outside the U.S.

TI may expressly designate certain products as completing a particular qualification (e.g., Q100, Military Grade, or Enhanced Product). Designers agree that it has the necessary expertise to select the product with the appropriate qualification designation for their applications and that proper product selection is at Designers' own risk. Designers are solely responsible for compliance with all legal and regulatory requirements in connection with such selection.

Designer will fully indemnify TI and its representatives against any damages, costs, losses, and/or liabilities arising out of Designer's non-compliance with the terms and provisions of this Notice.