



DirectPath™, 3-VRMS Line Driver With Adjustable Gain

Check for Samples: [DRV603](#)

FEATURES

- **DirectPath™**
 - Eliminates Pop/Clicks
 - Eliminates Output DC-Blocking Capacitors
 - Provides Flat Frequency Response 20 Hz–20 kHz
- **Low Noise and THD**
 - SNR > 109 dB
 - Typical $V_n < 7 \mu\text{Vms}$
 - THD+N < 0.002%
- **Output Voltage Into 2.5-k Ω Load**
 - 2 Vrms With 3.3-V Supply Voltage
 - 3 Vrms With 5-V Supply Voltage
- **Differential Input**
- **External Undervoltage Mute**

APPLICATIONS

- PDP / LCD TV
- Blu-ray Disc™, DVD Players
- Home Theater in a Box
- Set-Top Boxes

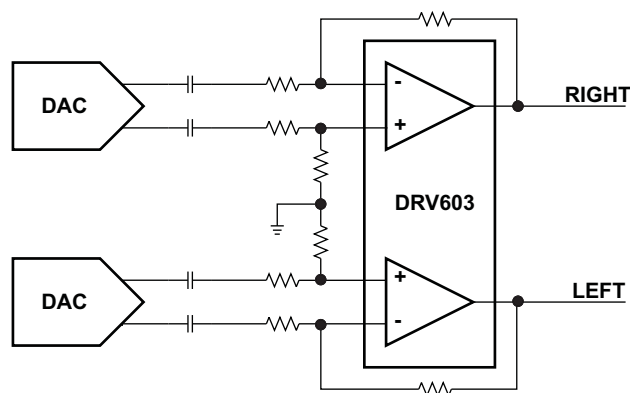

DESCRIPTION

The DRV603PW is a 3- V_{RMS} pop-free stereo line driver designed to allow the removal of the output dc-blocking capacitors for reduced component count and cost. The device is ideal for single-supply electronics where size and cost are critical design parameters.

Designed using TI's patented DirectPath™ technology, The DRV603 is capable of driving 3 V_{rms} into a 2.5-k Ω load with 5-V supply voltage. The device has differential inputs and uses external gain-setting resistors to support a gain range of ± 1 V/V to ± 10 V/V, and line outputs that have ± 8 kV IEC ESD protection. The DRV603 (occasionally referred to as the '603) has built-in shutdown control for pop-free on/off control. The DRV603 has an external and internal undervoltage detector that mutes the output.

Using the DRV603 in audio products can reduce component count considerably compared to traditional methods of generating a 3- V_{rms} output. The DRV603 does not require a power supply greater than 5 V to generate its 8.5- V_{pp} output, nor does it require a split-rail power supply. The DRV603 integrates its own charge pump to generate a negative supply rail that provides a clean, pop-free ground biased 3- V_{rms} output.

The DRV603 is available in a 14-pin TSSOP.

If the low noise and trimmed dc-offset and external undervoltage mute function are not beneficial in the application, TI recommends the footprint compatible DRV602.



Please be aware that an important notice concerning availability, standard warranty, and use in critical applications of Texas Instruments semiconductor products and disclaimers thereto appears at the end of this data sheet.

DirectPath is a trademark of Texas Instruments.
 Blu-ray Disc is a trademark of Blu-ray Disc Association.
 All other trademarks are the property of their respective owners.



These devices have limited built-in ESD protection. The leads should be shorted together or the device placed in conductive foam during storage or handling to prevent electrostatic damage to the MOS gates.

ORDERING INFORMATION⁽¹⁾

T _A	PACKAGE	TRANSPORT MEDIA, QUANTITY
–40°C to 85°C	DRV603PW	RAIL, 90 Tape and reel, 2000
	DRV603PWR	

(1) For the most current package and ordering information, see the Package Option Addendum at the end of this document, or see the TI Web site at www.ti.com.

ABSOLUTE MAXIMUM RATINGS⁽¹⁾

over operating free-air temperature range

	VALUE	UNIT
Supply voltage, V _{DD} to GND	–0.3 to 5.5	V
V _I Input voltage	V _{SS} – 0.3 to V _{DD} + 0.3	V
R _L Minimum load impedance	> 600	Ω
EN to GND	–0.3 to V _{DD} +0.3	V
T _J Maximum operating junction temperature range	–40 to 150	°C
T _{stg} Storage temperature range	–40 to 150	°C
ESD Electrostatic discharge, IEC ESD	OUTL, OUTR	±8
		kV

(1) Stresses beyond those listed under *absolute maximum ratings* may cause permanent damage to the device. These are stress ratings only, and functional operation of the device at these or any other conditions beyond those indicated under *recommended operating conditions* is not implied. Exposure to absolute-maximum-rated conditions for extended periods may affect device reliability.

DISSIPATION RATINGS

PACKAGE	R _{θJC} (°C/W)	R _{θJA} (°C/W)	POWER RATING ⁽¹⁾ AT T _A ≤ 25°C	POWER RATING ⁽¹⁾ AT T _A ≤ 70°C
TSSOP-14 (PW)	35	115 ⁽²⁾	870 mW	348 mW

- (1) Power rating is determined with a junction temperature of 125°C. This is the point where performance starts to degrade and long-term reliability starts to be reduced. Thermal management of the final PCB should strive to keep the junction temperature at or below 125°C for best performance and reliability.
- (2) These data were taken with the JEDEC high-K test printed circuit board (PCB). For the JEDEC low-K test PCB, the R_{θJA} is 185°C/W.

RECOMMENDED OPERATING CONDITIONS

	MIN	NOM	MAX	UNIT
V _{DD} Supply voltage	3	3.3	5.5	V
V _{IH} High-level input voltage		60		% of V _{DD}
V _{IL} Low-level input voltage		40		% of V _{DD}
T _A Operating free-air temperature	0		70	°C

ELECTRICAL CHARACTERISTICS

 $T_A = 25^\circ\text{C}$ (unless otherwise noted)

PARAMETER		TEST CONDITIONS	MIN	TYP	MAX	UNIT
$ V_{OS} $	Output offset voltage	$V_{DD} = 3\text{ V to }5\text{ V}$, input grounded, unity gain			1	mV
PSRR	Power-supply rejection ratio	$V_{DD} = 3\text{ V to }5\text{ V}$		88		dB
V_{OH}	High-level output voltage	$V_{DD} = 3.3\text{ V}$, $R_L = 2.5\text{ k}\Omega$	3.1			V
V_{OL}	Low-level output voltage	$V_{DD} = 3.3\text{ V}$, $R_L = 2.5\text{ k}\Omega$			-3.05	V
$ I_{IH} $	High-level input current (EN)	$V_{DD} = 5\text{ V}$, $V_I = V_{DD}$			1	μA
$ I_{IL} $	Low-level input current (EN)	$V_{DD} = 5\text{ V}$, $V_I = 0\text{ V}$			1	μA
I_{DD}	Supply current	$V_{DD} = 3.3\text{ V}$, no load, $EN = V_{DD}$		11		mA
		$V_{DD} = 5\text{ V}$, no load, $EN = V_{DD}$		12.5		
		Shutdown mode, $V_{DD} = 3\text{ V to }5\text{ V}$			1	

OPERATING CHARACTERISTICS

 $V_{DD} = 3.3\text{ V}$, $T_A = 25^\circ\text{C}$, $R_L = 2.5\text{ k}\Omega$, $C_{(PUMP)} = C_{(PVSS)} = 1\text{ }\mu\text{F}$, $C_{IN} = 10\text{ }\mu\text{F}$, $R_{IN} = 10\text{ k}\Omega$, $R_{fb} = 20\text{ k}\Omega$ (unless otherwise noted)

PARAMETER		TEST CONDITIONS	MIN	TYP	MAX	UNIT
V_O	Output voltage (outputs in phase)	THD = 1%, $V_{DD} = 3.3\text{ V}$, $f = 1\text{ kHz}$	2.05			V_{rms}
		THD = 1%, $V_{DD} = 5\text{ V}$, $f = 1\text{ kHz}$	3.01			
		THD = 1%, $V_{DD} = 5\text{ V}$, $f = 1\text{ kHz}$, $R_L = 100\text{ k}\Omega$	3.1			
THD+N	Total harmonic distortion plus noise	$V_O = 2\text{ }V_{rms}$, $f = 1\text{ kHz}$		0.001%		
	Crosstalk	$V_O = 2\text{ }V_{rms}$, $f = 1\text{ kHz}$		-100		dB
I_O	Maximum output current	$V_{DD} = 3.3\text{ V}$		20		mA
R_{IN}	Input resistor range		1	10	47	$\text{k}\Omega$
R_{fb}	Feedback resistor range		4.7	20	100	$\text{k}\Omega$
	Slew rate			4.5		$\text{V}/\mu\text{s}$
	Maximum capacitive load			220		pF
V_N	Noise output voltage	$BW = 20\text{ Hz to }22\text{ kHz}$, A-weighted		6		μV_{rms}
SNR	Signal-to-noise ratio	$V_O = 3\text{ }V_{rms}$, THD+N = 0.1%, $BW = 22\text{ kHz}$, A-weighted		112		dB
G_{BW}	Unity-gain bandwidth			8		MHz
A_{VO}	Open-loop voltage gain			150		dB
V_{uvp}	External undervoltage detection			1.25		V
I_{Hys}	External undervoltage detection hysteresis current			5		μA
f_{cp}	Charge pump frequency		225	450	675	kHz

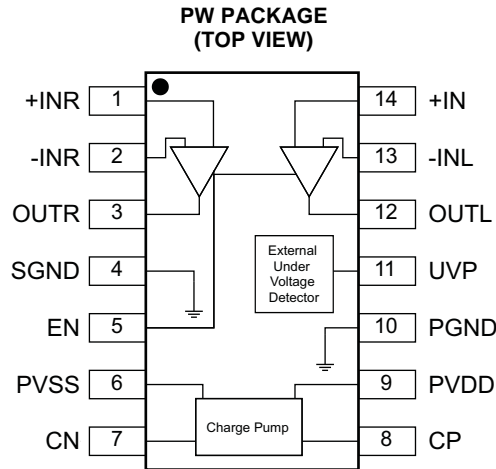

PIN FUNCTIONS

PIN		I/O ⁽¹⁾	DESCRIPTION
NAME	NO.		
+INR	1	I	Right-channel OPAMP positive input
-INR	2	I	Right-channel OPAMP negative input
OUTR	3	O	Right-channel OPAMP output
SGND	4	P	Signal ground
EN	5	I	Enable input, active-high
PVSS	6	P	Supply voltage
CN	7	I/O	Charge-pump flying capacitor negative terminal
CP	8	I/O	Charge-pump flying capacitor positive terminal
PVDD	9	P	Positive supply
PGND	10	P	Power ground
UVP	11	I	Undervoltage protection input
OUTL	12	O	Left-channel OPAMP output
-INL	13	I	Left-channel OPAMP negative input
+INL	14	I	Left-channel OPAMP positive input

(1) I = input, O = output, P = power

FUNCTIONAL BLOCK DIAGRAM

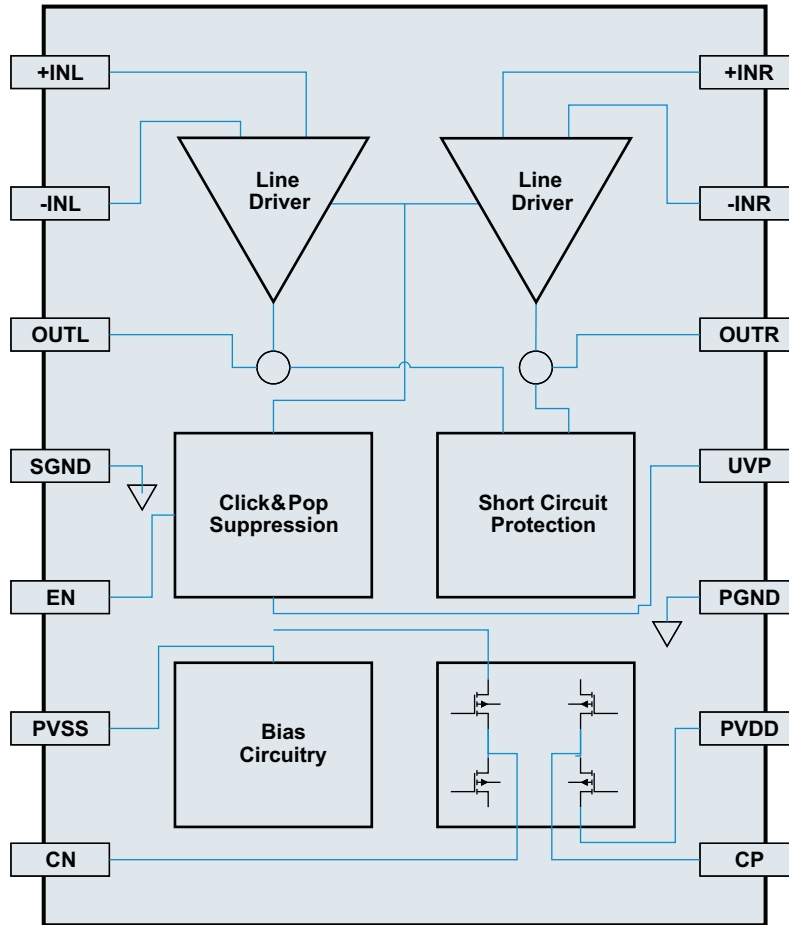

TYPICAL CHARACTERISTICS

$V_{DD} = 3.3\text{ V}$, $T_A = 25^\circ\text{C}$, $R_L = 2.5\text{ k}\Omega$, $C_{(PUMP)} = C_{(VSS)} = 1\ \mu\text{F}$, $C_{IN} = 10\ \mu\text{F}$, $R_{IN} = 10\text{ k}\Omega$, $R_{fb} = 20\text{ k}\Omega$ (unless otherwise noted)

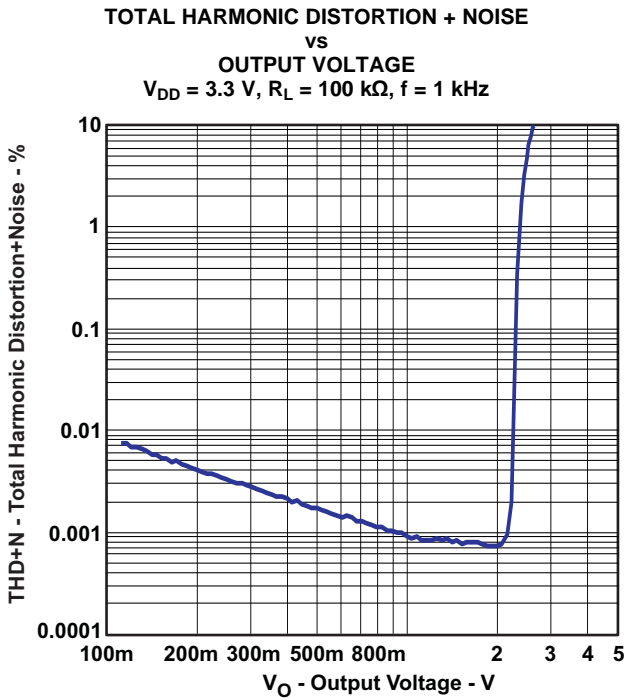

Figure 1.

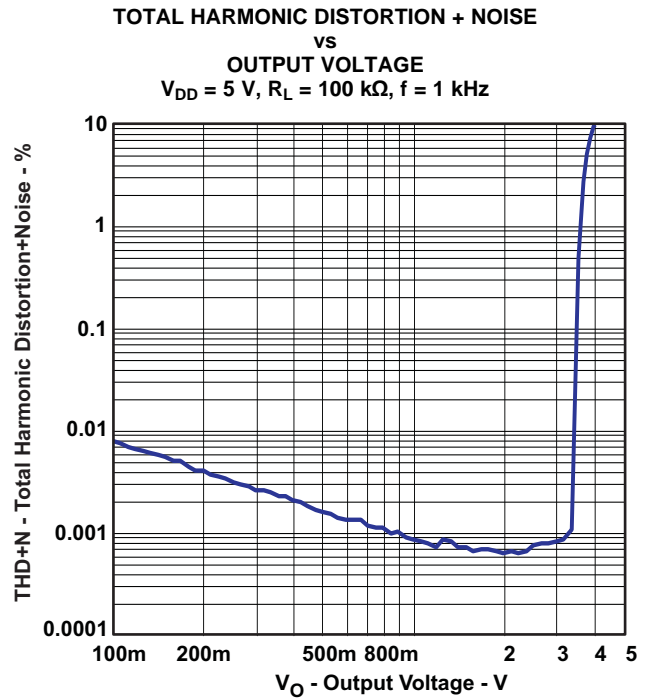

Figure 2.

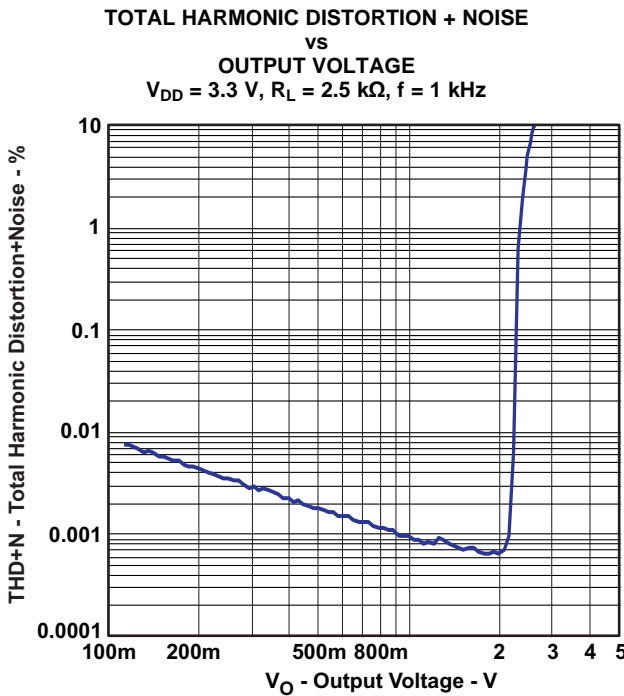

Figure 3.

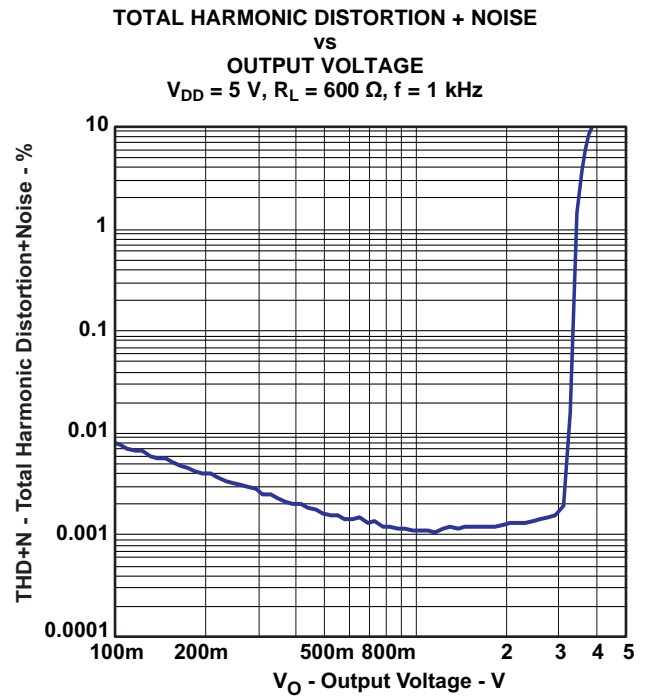

Figure 4.

TYPICAL CHARACTERISTICS (continued)

$V_{DD} = 3.3\text{ V}$, $T_A = 25^\circ\text{C}$, $R_L = 2.5\text{ k}\Omega$, $C_{(PUMP)} = C_{(VSS)} = 1\ \mu\text{F}$, $C_{IN} = 10\ \mu\text{F}$, $R_{IN} = 10\text{ k}\Omega$, $R_{fb} = 20\text{ k}\Omega$ (unless otherwise noted)

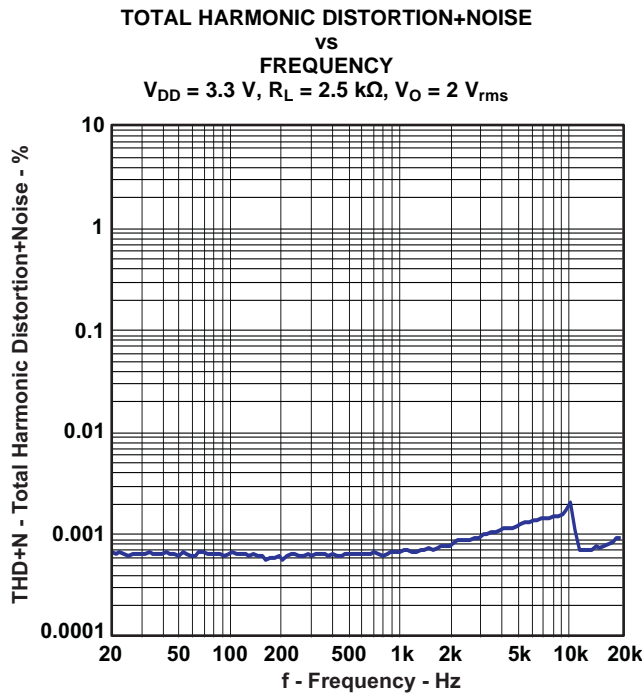

Figure 5.

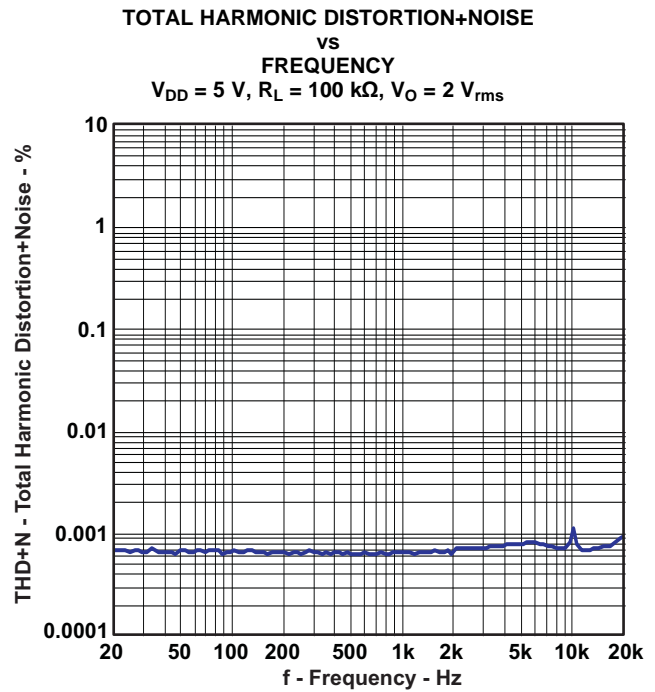

Figure 6.

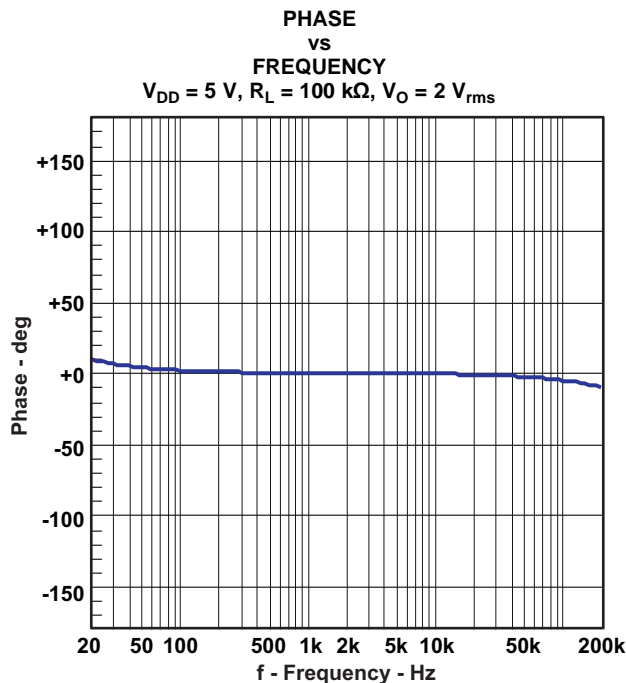

Figure 7.

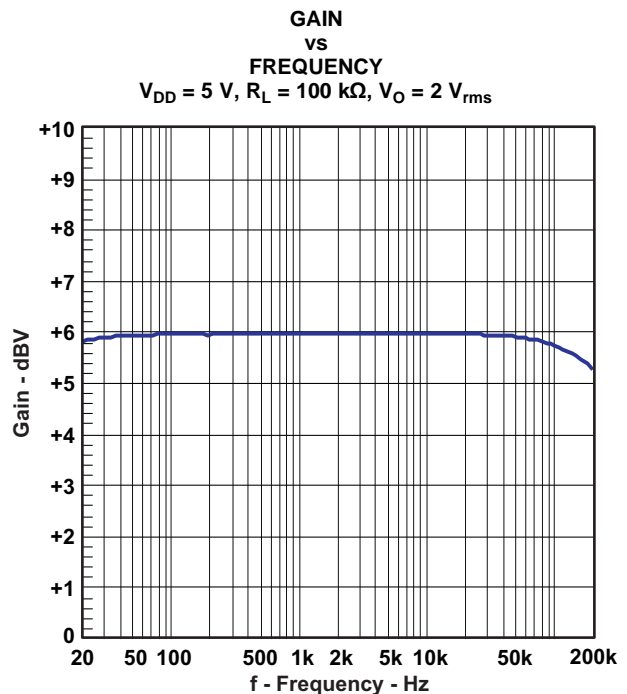

Figure 8.

TYPICAL CHARACTERISTICS (continued)

$V_{DD} = 3.3\text{ V}$, $T_A = 25^\circ\text{C}$, $R_L = 2.5\text{ k}\Omega$, $C_{(PUMP)} = C_{(VSS)} = 1\ \mu\text{F}$, $C_{IN} = 10\ \mu\text{F}$, $R_{IN} = 10\text{ k}\Omega$, $R_{fb} = 20\text{ k}\Omega$ (unless otherwise noted)

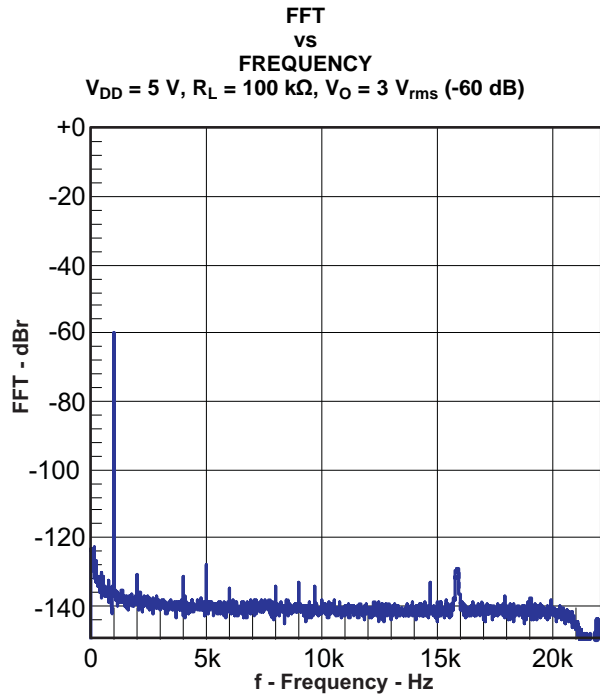

Figure 9.

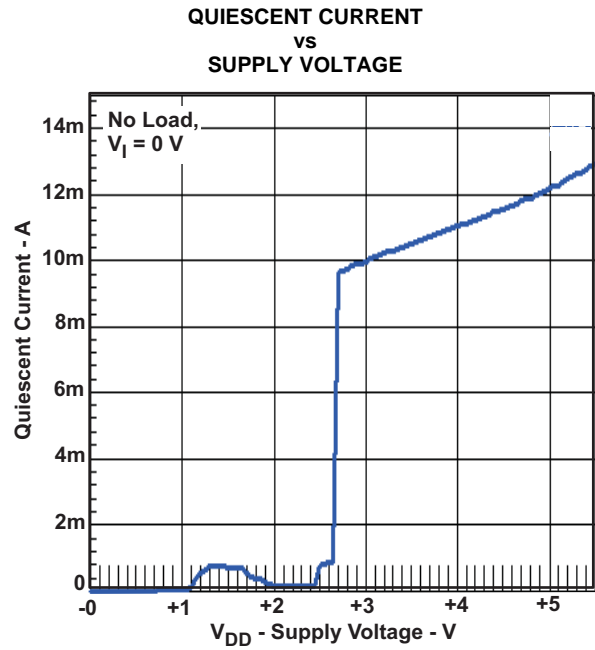

Figure 10.

APPLICATION INFORMATION

LINE DRIVER AMPLIFIERS

Single-supply line-driver amplifiers typically require dc-blocking capacitors. The top drawing in [Figure 11](#) illustrates the conventional line-driver amplifier connection to the load and output signal.

DC blocking capacitors are often large in value, and a mute circuit is needed during power up to minimize click and pop. The output capacitor and mute circuit consume PCB area and increase cost of assembly, and can reduce the fidelity of the audio output signal.

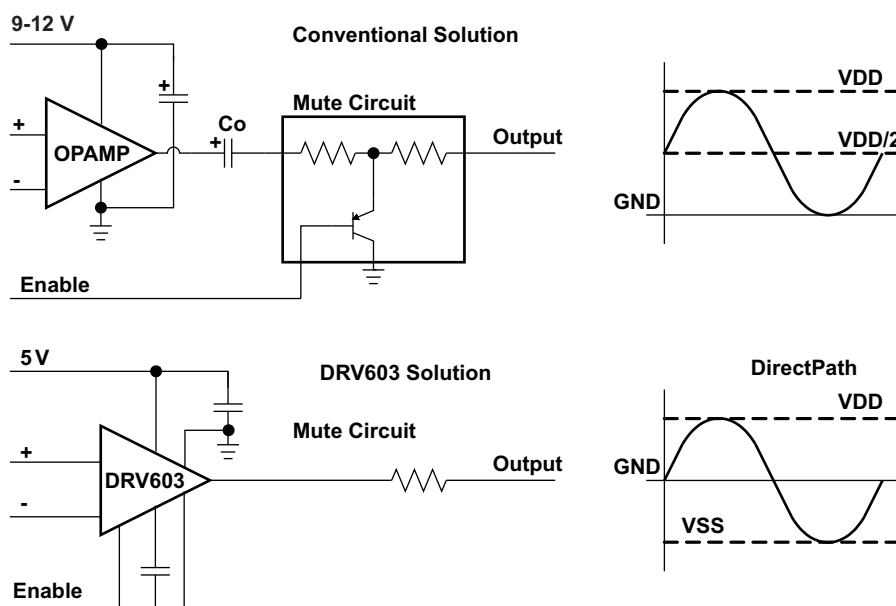

Figure 11. Conventional and DirectPath Line Driver

The DirectPath™ amplifier architecture operates from a single supply but makes use of an internal charge pump to provide a negative voltage rail.

Combining the user-provided positive rail and the negative rail generated by the IC, the device operates in what is effectively a split supply mode.

The output voltages are now centered at zero volts with the capability to swing to the positive rail or negative rail. Combining this with the built-in click and pop reduction circuit, the DirectPath™ amplifier requires no output dc blocking capacitors.

The bottom block diagram and waveform of [Figure 11](#) illustrate the ground-referenced line-driver architecture. This is the architecture of the DRV603.

CHARGE PUMP FLYING CAPACITOR AND PVSS CAPACITOR

The charge pump flying capacitor serves to transfer charge during the generation of the negative supply voltage. The PVSS capacitor must be at least equal to the charge pump capacitor in order to allow maximum charge transfer. Low-ESR capacitors are an ideal selection, and a value of 1 μF is typical. Capacitor values that are smaller than 1 μF can be used, but the maximum output voltage may be reduced and the device may not operate to specifications.

DECOUPLING CAPACITORS

The DRV603 is a DirectPath™ line-driver amplifier that requires adequate power supply decoupling to ensure that the noise and total harmonic distortion (THD) are low. A good low equivalent-series-resistance (ESR) ceramic capacitor, typically 1 μF , placed as close as possible to the device V_{DD} lead works best. Placing this decoupling capacitor close to the DRV603 is important for the performance of the amplifier. For filtering lower-frequency noise signals, a 10- μF or greater capacitor placed near the audio power amplifier would also help, but it is not required in most applications because of the high PSRR of this device.

GAIN-SETTING RESISTOR RANGES

The gain-setting resistors, R_{IN} and R_{fb} , must be chosen so that noise, stability, and input capacitor size of the DRV603 are kept within acceptable limits. Voltage gain is defined as R_{fb} divided by R_{IN} .

Selecting values that are too low demands a large input ac-coupling capacitor, C_{IN} . Selecting values that are too high increases the noise of the amplifier. Table 1 lists the recommended resistor values for different gain settings.

Table 1. Recommended Resistor Values

INPUT RESISTOR VALUE, R_{IN}	FEEDBACK RESISTOR VALUE, R_{fb}	DIFFERENTIAL INPUT GAIN	INVERTING INPUT GAIN	NONINVERTING INPUT GAIN
22 k Ω	22 k Ω	1 V/V	-1 V/V	2 V/V
15 k Ω	30 k Ω	1.5 V/V	-1.5 V/V	2.5 V/V
33 k Ω	68 k Ω	2.1 V/V	-2.1 V/V	3.1 V/V
10 k Ω	100 k Ω	10 V/V	-10 V/V	11 V/V

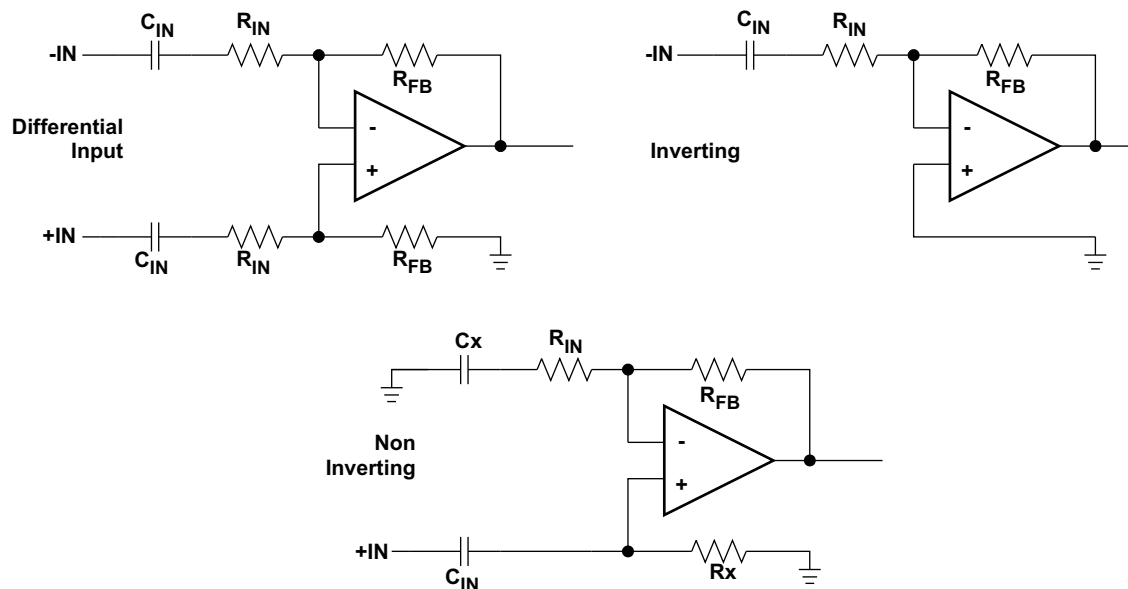

Figure 12. Differential, Inverting and Non-Inverting Gain Configurations

INPUT-BLOCKING CAPACITORS

DC input-blocking capacitors are required to be added in series with the audio signal into the input pins of the DRV603. These capacitors block the dc portion of the audio source and allow the DRV603 inputs to be properly biased to provide maximum performance.

These capacitors form a high-pass filter with the input resistor, R_{IN} . The cutoff frequency is calculated using Equation 1. For this calculation, the capacitance used is the input-blocking capacitor and the resistance is the input resistor chosen from Table 1. Then the frequency and/or capacitance can be determined when one of the two values is given.

$$f_{C_{IN}} = \frac{1}{2\pi R_{IN} C_{IN}} \quad \text{or} \quad C_{IN} = \frac{1}{2\pi f_{C_{IN}} R_{IN}} \quad (1)$$

USING THE DRV603 AS A SECOND-ORDER FILTER

Several audio DACs used today require an external low-pass filter to remove out-of-band noise. This is possible with the DRV603, as it can be used like a standard OPAMP. Several filter topologies can be implemented, both single-ended and differential. In Figure 13, a multi-feedback (MFB) with differential input and single-ended input is shown.

An ac-coupling capacitor to remove dc content from the source is shown; it serves to block any dc content from the source and lowers the dc-gain to 1, helping reducing the output dc-offset to minimum.

The component values can be calculated with the help of the TI FilterPro™ program available on the TI website at:

<http://focus.ti.com/docs/toolsw/folders/print/filterpro.html>

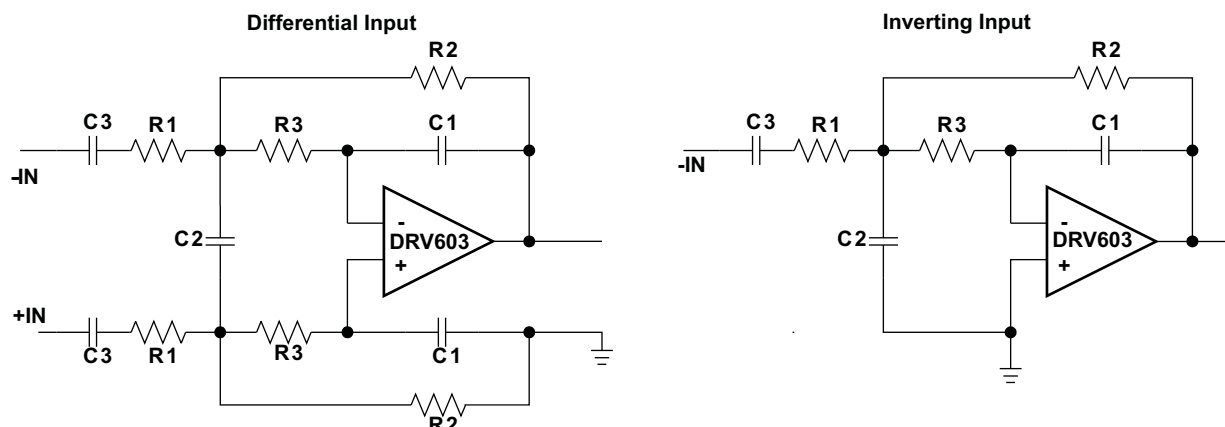

Figure 13. Second-Order Active Low-Pass Filter

The resistor values should have a low value for obtaining low noise, but should also have a high enough value to get a small size ac-coupling capacitor. Using 5.6 kΩ for the resistors, $C1 = 220$ pF, and $C2 = 470$ pF, a DNR of 112 dB can be achieved with a 10-μF input ac-coupling capacitor.

POP-FREE POWER UP

Pop-free power up is ensured by keeping the \overline{SD} (shutdown pin) low during power-supply ramp up and ramp down. The \overline{SD} pin should be kept low until the input ac-coupling capacitors are fully charged before asserting the \overline{SD} pin high to achieve pop-less power up. Figure 14 illustrates the preferred sequence.

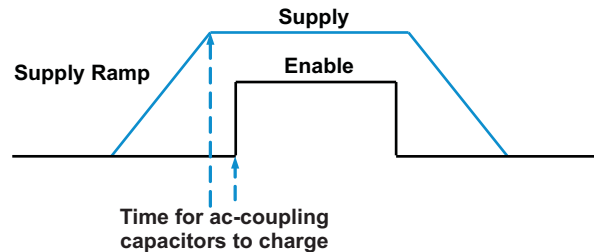

Figure 14. Power-Up Sequence

EXTERNAL UNDERVOLTAGE DETECTION

External undervoltage detection can be used to mute/shut down the DRV603 before an input device can generate a pop.

The shutdown threshold at the UVP pin is 1.25 V. The user selects a resistor divider to obtain the shutdown threshold and hysteresis for the specific application. The thresholds can be determined as follows:

$$V_{UVP} = 1.25 \text{ V} \times (R11 + R12) / R12$$

$$\text{Hysteresis} = 5 \mu\text{A} \times R13 \times (R11 + R12) / R12$$

with the condition $R13 \gg R11/R12$.

For example, to obtain $V_{UVP} = 5 \text{ V}$ and 1-V hysteresis, $R11 = 3 \text{ k}\Omega$, $R12 = 1 \text{ k}\Omega$ and $R13 = 50 \text{ k}\Omega$.

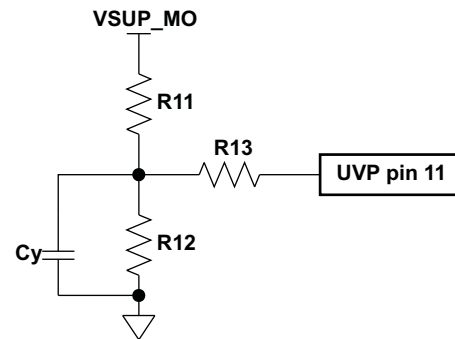

CAPACITIVE LOAD

The DRV603 has the ability to drive a high capacitive load up to 220 pF directly. Higher capacitive loads can be accepted by adding a series resistor of 47 Ω or larger.

LAYOUT RECOMMENDATIONS

A proposed layout for the DRV603 can be seen in the DRV603EVM User's Guide (SLOU248), and the Gerber files can be downloaded from <http://focus.ti.com/docs/toolsw/folders/print/drv603evm.html>. To access this information, open the DRV603 product folder and look in the Tools and Software folder.

GAIN-SETTING RESISTORS

The gain-setting resistors, R_{IN} and R_{fb} , must be placed close to the input pins to minimize capacitive loading on these input pins and to ensure maximum stability of the DRV603. For the recommended PCB layout, see the DRV603EVM user's guide (SLOU248).

APPLICATION CIRCUIT

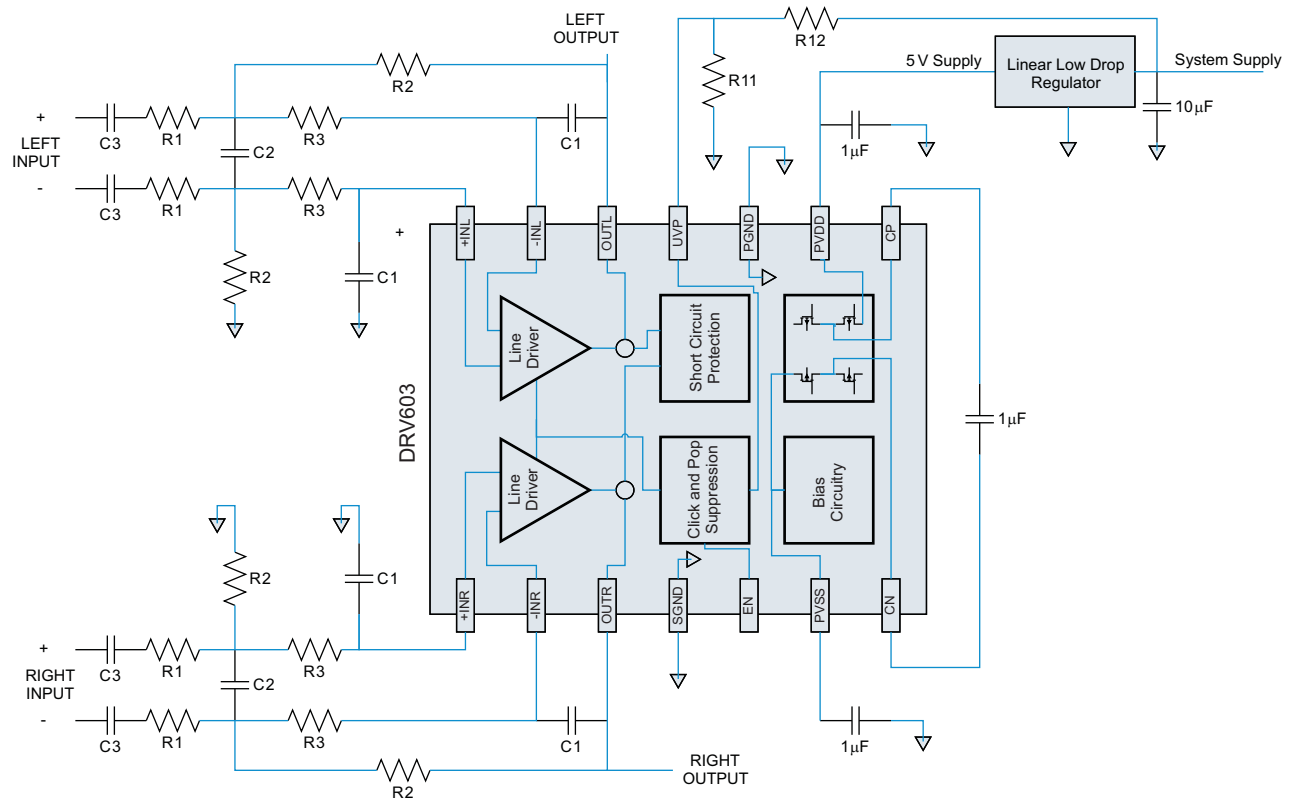

R1 = 5.6 kΩ, R2 = 5.6 kΩ, R3 = 5.6 kΩ, C1 = 220 pF, C2 = 470 pF

Differential-input, single-ended output, second-order filter

REVISION HISTORY

NOTE: Page numbers of current version may differ from previous versions.

Changes from Revision A (February 2009) to Revision B	Page
• Changed Crosstalk spec from –80dB to –100dB	3
• Added missing voltage value (1.25V) to <i>External Undervoltage Detection</i> threshold equation.	12

Changes from Revision B (October 2009) to Revision C	Page
• Changed maximum operating junction temperature	2
• In Dissipation Ratings section, changed θ_{Jx} to $R_{\theta Jx}$ in three places and 185°C to 185°C/W	2
• Corrected reference to Figure 11	9
• Added cross-reference to Figure 13	11

PACKAGING INFORMATION

Orderable Device	Status (1)	Package Type	Package Drawing	Pins	Package Qty	Eco Plan (2)	Lead/Ball Finish	MSL Peak Temp (3)	Op Temp (°C)	Top-Side Markings (4)	Samples
DRV603PW	ACTIVE	TSSOP	PW	14	90	Green (RoHS & no Sb/Br)	CU NIPDAU	Level-1-260C-UNLIM	-40 to 85	DRV603	Samples
DRV603PWR	ACTIVE	TSSOP	PW	14	2000	Green (RoHS & no Sb/Br)	CU NIPDAU	Level-1-260C-UNLIM	-40 to 85	DRV603	Samples

(1) The marketing status values are defined as follows:

ACTIVE: Product device recommended for new designs.

LIFEBUY: TI has announced that the device will be discontinued, and a lifetime-buy period is in effect.

NRND: Not recommended for new designs. Device is in production to support existing customers, but TI does not recommend using this part in a new design.

PREVIEW: Device has been announced but is not in production. Samples may or may not be available.

OBSOLETE: TI has discontinued the production of the device.

(2) Eco Plan - The planned eco-friendly classification: Pb-Free (RoHS), Pb-Free (RoHS Exempt), or Green (RoHS & no Sb/Br) - please check <http://www.ti.com/productcontent> for the latest availability information and additional product content details.

TBD: The Pb-Free/Green conversion plan has not been defined.

Pb-Free (RoHS): TI's terms "Lead-Free" or "Pb-Free" mean semiconductor products that are compatible with the current RoHS requirements for all 6 substances, including the requirement that lead not exceed 0.1% by weight in homogeneous materials. Where designed to be soldered at high temperatures, TI Pb-Free products are suitable for use in specified lead-free processes.

Pb-Free (RoHS Exempt): This component has a RoHS exemption for either 1) lead-based flip-chip solder bumps used between the die and package, or 2) lead-based die adhesive used between the die and leadframe. The component is otherwise considered Pb-Free (RoHS compatible) as defined above.

Green (RoHS & no Sb/Br): TI defines "Green" to mean Pb-Free (RoHS compatible), and free of Bromine (Br) and Antimony (Sb) based flame retardants (Br or Sb do not exceed 0.1% by weight in homogeneous material)

(3) MSL, Peak Temp. -- The Moisture Sensitivity Level rating according to the JEDEC industry standard classifications, and peak solder temperature.

(4) Multiple Top-Side Markings will be inside parentheses. Only one Top-Side Marking contained in parentheses and separated by a "~" will appear on a device. If a line is indented then it is a continuation of the previous line and the two combined represent the entire Top-Side Marking for that device.

Important Information and Disclaimer: The information provided on this page represents TI's knowledge and belief as of the date that it is provided. TI bases its knowledge and belief on information provided by third parties, and makes no representation or warranty as to the accuracy of such information. Efforts are underway to better integrate information from third parties. TI has taken and continues to take reasonable steps to provide representative and accurate information but may not have conducted destructive testing or chemical analysis on incoming materials and chemicals. TI and TI suppliers consider certain information to be proprietary, and thus CAS numbers and other limited information may not be available for release.

In no event shall TI's liability arising out of such information exceed the total purchase price of the TI part(s) at issue in this document sold by TI to Customer on an annual basis.

TAPE AND REEL INFORMATION



QUADRANT ASSIGNMENTS FOR PIN 1 ORIENTATION IN TAPE



*All dimensions are nominal

Device	Package Type	Package Drawing	Pins	SPQ	Reel Diameter (mm)	Reel Width W1 (mm)	A0 (mm)	B0 (mm)	K0 (mm)	P1 (mm)	W (mm)	Pin1 Quadrant
DRV603PWR	TSSOP	PW	14	2000	330.0	12.4	6.9	5.6	1.6	8.0	12.0	Q1

TAPE AND REEL BOX DIMENSIONS



*All dimensions are nominal

Device	Package Type	Package Drawing	Pins	SPQ	Length (mm)	Width (mm)	Height (mm)
DRV603PWR	TSSOP	PW	14	2000	367.0	367.0	38.0

IMPORTANT NOTICE

Texas Instruments Incorporated (TI) reserves the right to make corrections, enhancements, improvements and other changes to its semiconductor products and services per JESD46, latest issue, and to discontinue any product or service per JESD48, latest issue. Buyers should obtain the latest relevant information before placing orders and should verify that such information is current and complete.

TI's published terms of sale for semiconductor products (<http://www.ti.com/sc/docs/stdterms.htm>) apply to the sale of packaged integrated circuit products that TI has qualified and released to market. Additional terms may apply to the use or sale of other types of TI products and services.

Reproduction of significant portions of TI information in TI data sheets is permissible only if reproduction is without alteration and is accompanied by all associated warranties, conditions, limitations, and notices. TI is not responsible or liable for such reproduced documentation. Information of third parties may be subject to additional restrictions. Resale of TI products or services with statements different from or beyond the parameters stated by TI for that product or service voids all express and any implied warranties for the associated TI product or service and is an unfair and deceptive business practice. TI is not responsible or liable for any such statements.

Buyers and others who are developing systems that incorporate TI products (collectively, "Designers") understand and agree that Designers remain responsible for using their independent analysis, evaluation and judgment in designing their applications and that Designers have full and exclusive responsibility to assure the safety of Designers' applications and compliance of their applications (and of all TI products used in or for Designers' applications) with all applicable regulations, laws and other applicable requirements. Designer represents that, with respect to their applications, Designer has all the necessary expertise to create and implement safeguards that (1) anticipate dangerous consequences of failures, (2) monitor failures and their consequences, and (3) lessen the likelihood of failures that might cause harm and take appropriate actions. Designer agrees that prior to using or distributing any applications that include TI products, Designer will thoroughly test such applications and the functionality of such TI products as used in such applications.

TI's provision of technical, application or other design advice, quality characterization, reliability data or other services or information, including, but not limited to, reference designs and materials relating to evaluation modules, (collectively, "TI Resources") are intended to assist designers who are developing applications that incorporate TI products; by downloading, accessing or using TI Resources in any way, Designer (individually or, if Designer is acting on behalf of a company, Designer's company) agrees to use any particular TI Resource solely for this purpose and subject to the terms of this Notice.

TI's provision of TI Resources does not expand or otherwise alter TI's applicable published warranties or warranty disclaimers for TI products, and no additional obligations or liabilities arise from TI providing such TI Resources. TI reserves the right to make corrections, enhancements, improvements and other changes to its TI Resources. TI has not conducted any testing other than that specifically described in the published documentation for a particular TI Resource.

Designer is authorized to use, copy and modify any individual TI Resource only in connection with the development of applications that include the TI product(s) identified in such TI Resource. NO OTHER LICENSE, EXPRESS OR IMPLIED, BY ESTOPPEL OR OTHERWISE TO ANY OTHER TI INTELLECTUAL PROPERTY RIGHT, AND NO LICENSE TO ANY TECHNOLOGY OR INTELLECTUAL PROPERTY RIGHT OF TI OR ANY THIRD PARTY IS GRANTED HEREIN, including but not limited to any patent right, copyright, mask work right, or other intellectual property right relating to any combination, machine, or process in which TI products or services are used. Information regarding or referencing third-party products or services does not constitute a license to use such products or services, or a warranty or endorsement thereof. Use of TI Resources may require a license from a third party under the patents or other intellectual property of the third party, or a license from TI under the patents or other intellectual property of TI.

TI RESOURCES ARE PROVIDED "AS IS" AND WITH ALL FAULTS. TI DISCLAIMS ALL OTHER WARRANTIES OR REPRESENTATIONS, EXPRESS OR IMPLIED, REGARDING RESOURCES OR USE THEREOF, INCLUDING BUT NOT LIMITED TO ACCURACY OR COMPLETENESS, TITLE, ANY EPIDEMIC FAILURE WARRANTY AND ANY IMPLIED WARRANTIES OF MERCHANTABILITY, FITNESS FOR A PARTICULAR PURPOSE, AND NON-INFRINGEMENT OF ANY THIRD PARTY INTELLECTUAL PROPERTY RIGHTS. TI SHALL NOT BE LIABLE FOR AND SHALL NOT DEFEND OR INDEMNIFY DESIGNER AGAINST ANY CLAIM, INCLUDING BUT NOT LIMITED TO ANY INFRINGEMENT CLAIM THAT RELATES TO OR IS BASED ON ANY COMBINATION OF PRODUCTS EVEN IF DESCRIBED IN TI RESOURCES OR OTHERWISE. IN NO EVENT SHALL TI BE LIABLE FOR ANY ACTUAL, DIRECT, SPECIAL, COLLATERAL, INDIRECT, PUNITIVE, INCIDENTAL, CONSEQUENTIAL OR EXEMPLARY DAMAGES IN CONNECTION WITH OR ARISING OUT OF TI RESOURCES OR USE THEREOF, AND REGARDLESS OF WHETHER TI HAS BEEN ADVISED OF THE POSSIBILITY OF SUCH DAMAGES.

Unless TI has explicitly designated an individual product as meeting the requirements of a particular industry standard (e.g., ISO/TS 16949 and ISO 26262), TI is not responsible for any failure to meet such industry standard requirements.

Where TI specifically promotes products as facilitating functional safety or as compliant with industry functional safety standards, such products are intended to help enable customers to design and create their own applications that meet applicable functional safety standards and requirements. Using products in an application does not by itself establish any safety features in the application. Designers must ensure compliance with safety-related requirements and standards applicable to their applications. Designer may not use any TI products in life-critical medical equipment unless authorized officers of the parties have executed a special contract specifically governing such use. Life-critical medical equipment is medical equipment where failure of such equipment would cause serious bodily injury or death (e.g., life support, pacemakers, defibrillators, heart pumps, neurostimulators, and implantables). Such equipment includes, without limitation, all medical devices identified by the U.S. Food and Drug Administration as Class III devices and equivalent classifications outside the U.S.

TI may expressly designate certain products as completing a particular qualification (e.g., Q100, Military Grade, or Enhanced Product). Designers agree that it has the necessary expertise to select the product with the appropriate qualification designation for their applications and that proper product selection is at Designers' own risk. Designers are solely responsible for compliance with all legal and regulatory requirements in connection with such selection.

Designer will fully indemnify TI and its representatives against any damages, costs, losses, and/or liabilities arising out of Designer's non-compliance with the terms and provisions of this Notice.