



Is Now Part of



ON Semiconductor®

To learn more about ON Semiconductor, please visit our website at
www.onsemi.com

Please note: As part of the Fairchild Semiconductor integration, some of the Fairchild orderable part numbers will need to change in order to meet ON Semiconductor's system requirements. Since the ON Semiconductor product management systems do not have the ability to manage part nomenclature that utilizes an underscore (_), the underscore (_) in the Fairchild part numbers will be changed to a dash (-). This document may contain device numbers with an underscore (_). Please check the ON Semiconductor website to verify the updated device numbers. The most current and up-to-date ordering information can be found at www.onsemi.com. Please email any questions regarding the system integration to Fairchild_questions@onsemi.com.

ON Semiconductor and the ON Semiconductor logo are trademarks of Semiconductor Components Industries, LLC dba ON Semiconductor or its subsidiaries in the United States and/or other countries. ON Semiconductor owns the rights to a number of patents, trademarks, copyrights, trade secrets, and other intellectual property. A listing of ON Semiconductor's product/patent coverage may be accessed at www.onsemi.com/site/pdf/Patent-Marking.pdf. ON Semiconductor reserves the right to make changes without further notice to any products herein. ON Semiconductor makes no warranty, representation or guarantee regarding the suitability of its products for any particular purpose, nor does ON Semiconductor assume any liability arising out of the application or use of any product or circuit, and specifically disclaims any and all liability, including without limitation special, consequential or incidental damages. Buyer is responsible for its products and applications using ON Semiconductor products, including compliance with all laws, regulations and safety requirements or standards, regardless of any support or applications information provided by ON Semiconductor. "Typical" parameters which may be provided in ON Semiconductor data sheets and/or specifications can and do vary in different applications and actual performance may vary over time. All operating parameters, including "Typicals" must be validated for each customer application by customer's technical experts. ON Semiconductor does not convey any license under its patent rights nor the rights of others. ON Semiconductor products are not designed, intended, or authorized for use as a critical component in life support systems or any FDA Class 3 medical devices or medical devices with a same or similar classification in a foreign jurisdiction or any devices intended for implantation in the human body. Should Buyer purchase or use ON Semiconductor products for any such unintended or unauthorized application, Buyer shall indemnify and hold ON Semiconductor and its officers, employees, subsidiaries, affiliates, and distributors harmless against all claims, costs, damages, and expenses, and reasonable attorney fees arising out of, directly or indirectly, any claim of personal injury or death associated with such unintended or unauthorized use, even if such claim alleges that ON Semiconductor was negligent regarding the design or manufacture of the part. ON Semiconductor is an Equal Opportunity/Affirmative Action Employer. This literature is subject to all applicable copyright laws and is not for resale in any manner.

FAN7387V

Ballast Control IC for Compact Fluorescent Lamp

Features

- Integrated Half-Bridge MOSFET
- Internal Clock Using RCT
- Enable External Sync Function Using RCT
- Dead-Time Control by using Resistor
- Shut Down (Disable Mode)
- Internal Shunt Regulator
- UVLO Function High and Low Side

Applications

- Compact Fluorescent Lamp Ballast

Description

The FAN7387V, developed using Fairchild's unique high-voltage process and system-in-package (SiP) concept, is a ballast-control integrated circuit (IC) for a compact fluorescent lamp (CFL). The FAN7387V has a simple oscillating circuit using an external resistor and capacitor so the frequency variation is stable across the temperature range. FAN7387V has a external pin for dead time control and shutdown. By using this resistor, a designer can choose the optimum dead time to reduce the power loss on internal switching devices (MOSFETs).

8-DIP



Ordering Information

Part Number	Operating Temperature	Package	Packing Method
FAN7387VN	-40 to +125°C	8-Lead, Dual-In-line Package (DIP)	Tube

Typical Applications Diagrams

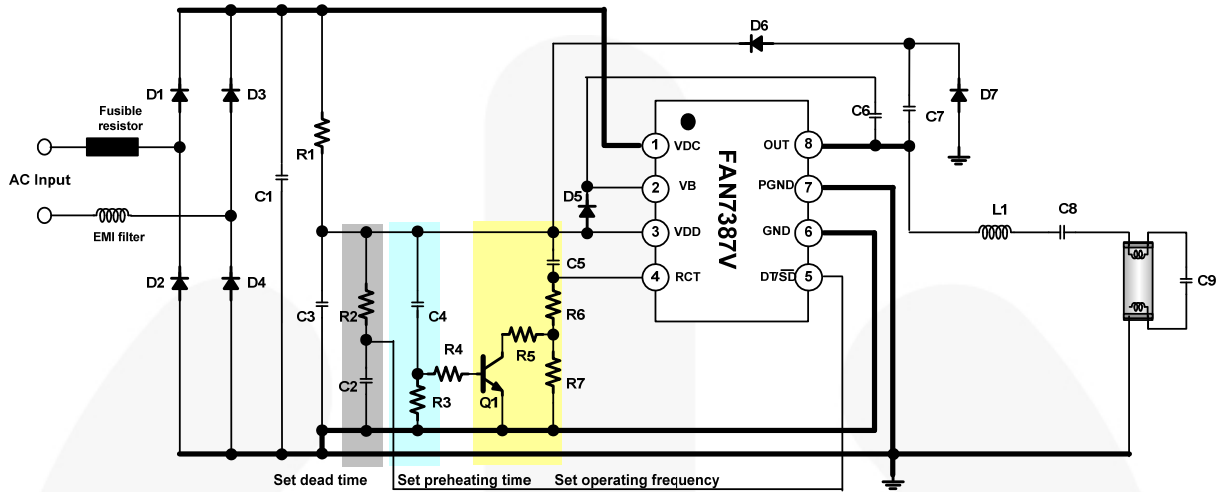

Figure 1. Typical Application Circuit for Fluorescent Lamp (Rapid Starting Method without PTC)

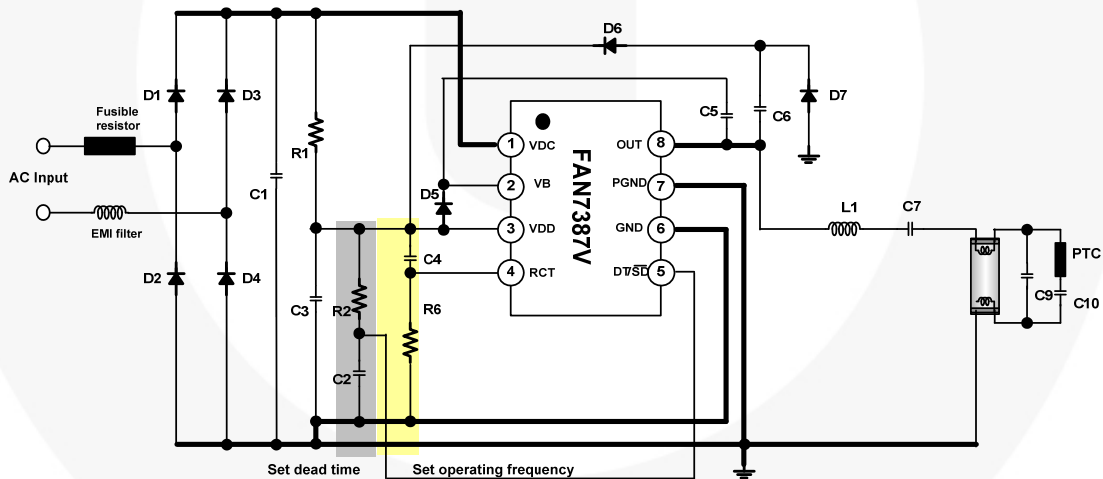

Figure 2. Typical Application Circuit for Fluorescent Lamp (Rapid Starting Method with PTC)

Internal Block Diagram

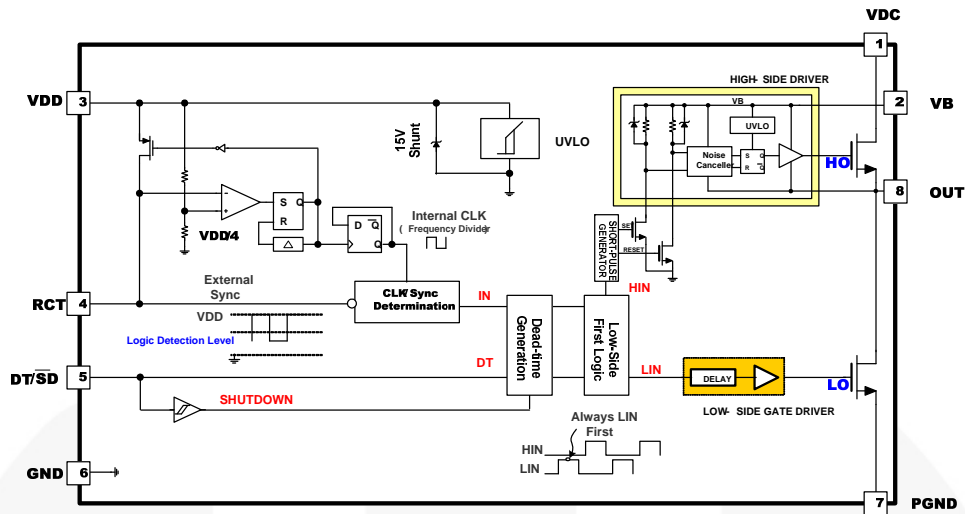

Figure 3. Functional Block Diagram

Pin Configuration

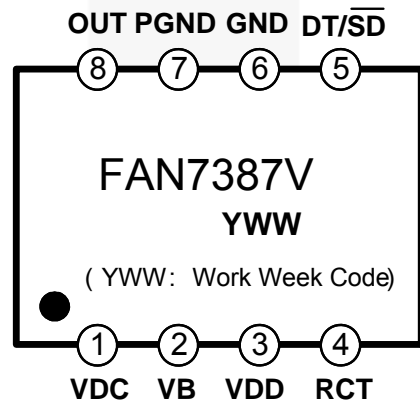

Figure 4. Pin Configurations (Top View)

Pin Definitions

Pin #	Name	Description
1	VDC	High-voltage Supply
2	VB	High-Side Floating Supply
3	VDD	Supply Voltage
4	RCT	Oscillator Frequency Set Resistor and Capacitor
5	DT/SD	Dead Time Set Resistor
6	GND	Signal Ground
7	PGND	Power Ground
8	OUT	High-Side Floating Supply Return

Absolute Maximum Ratings

Stresses exceeding the absolute maximum ratings may damage the device. The device may not function or be operable above the recommended operating conditions and stressing the parts to these levels is not recommended. In addition, extended exposure to stresses above the recommended operating conditions may affect device reliability. The absolute maximum ratings are stress ratings only. $T_A=25^{\circ}\text{C}$ unless otherwise specified.

Symbol	Parameter	Min.	Typ.	Max.	Unit
VB	High-Side Floating Supply	-0.3		465.0	V
V _{OUT}	High-Side Floating Supply Return	-0.3		440.0	V
V _{RCT}	RCT Pins Input Voltage		V _{DD}		V
I _{CL}	Clamping Current Level ⁽¹⁾			25	mA
dV _{OUT} /dt	Allowable Offset Voltage Slew Rate		50		V/ns
T _A	Operating Temperature Range	-40		+125	°C
T _{STG}	Storage Temperature Range	-65		+150	°C
P _D	Power Dissipation		2.1		W
Θ _{JA}	Thermal Resistance (Junction-to-Air)		70		°C/W

Note:

- Do not supply a low-impedance voltage source to the internal clamping Zener diode between the GND and the VDD pin of this device.

Electrical Characteristics

V_{BIAS} (V_{DD} , $V_B - V_{OUT}$)=14.0V, T_A =25°C, unless otherwise specified.

Symbol	Parameter	Conditions	Min.	Typ.	Max.	Unit
High Voltage Supply Section						
V_{DC}	High Voltage Supply Voltage		440			V
Low-Side Supply Characteristics (V_{DD})						
V_{DDUV+}	V_{DD} UVLO Positive-Going Threshold	V_{DD} Increasing	9	11	13	V
V_{DDUV-}	V_{DD} UVLO Negative-Going Threshold	V_{DD} Decreasing	7.8	8.8	9.8	
V_{DDUHY}	V_{DD} -Side UVLO Hysteresis			2.2		
V_{CL}	Supply Camping Voltage	$I_{DD}=10mA$	14.4	15.4		
I_{ST}	Startup Supply Current	$V_{DD}=9V$		60	90	μA
I_{QDD}	Low-Side Quiescent Supply Current	$R_{DT}=100k\Omega$		230	380	
I_{DD}	Dynamic Operating Supply Current	20kHz, $C_L=1nF$		0.6		mA
High-Side Supply Characteristics ($V_B - V_{OUT}$)						
V_{HSUV+}	High-Side UVLO Positive-Going Threshold	$V_B - V_{OUT}$ Increasing	8	9	10	V
V_{HSUV-}	High-Side UVLO Negative-Going Threshold	$V_B - V_{OUT}$ Decreasing	7.5	8.5	9.5	
V_{HSUHY}	V_{BS} Supply UVLO Hysteresis			0.5		
I_{QHS}	High-Side Quiescent Supply Current			50	90	μA
I_{PBS}	High-Side Dynamic Operating Supply Current	20kHz, $C_L=1nF$		130	180	
Oscillator Characteristics						
f_{osc}	Oscillation Frequency	$R_T=50k\Omega$, $C_T=330pF$	18	20	22	kHz
D	Duty Cycle	Running Mode	47.5	49.0		%
V_{RCT+}	Upper Threshold Voltage of RCT	Running Mode		V_{DD}		V
V_{RCT-}	Lower Threshold Voltage of RCT	Running Mode		$V_{DD}/4$		
V_{IH}	Logic "1" Input Voltage of RCT	Running Mode		$3/4 V_{DD}$		
V_{IL}	Logic "0" Input Voltage of RCT	Running Mode			$3/5 V_{DD}$	
t_D	Dead Time	$R_{DT}=100k\Omega$	440	540	640	ns
t_{DMIN}	Minimum Dead Time	$V_{DT/\overline{SD}}=V_{DD}$	280	400	520	
Protection Characteristics						
V_{SD+}	Shutdown "1" Input Voltage	$V_{SD/\overline{DT}}=0$ After Run Mode	2.5			V
V_{SD-}	Shutdown "0" Input Voltage				1	
I_{SD}	Shutdown Current				350	μA
t_{SD}	Shutdown Propagation Delay			180		Ns
Internal MOSFET Section						
$I_{LK MOS}$	Internal MOSFET Leakage Current	$V_{DS}=400V$			50	μA
R_{ON}	Static Drain-Source On-Resistance	$V_{GS}=10V$, $I_D=190mA$		4.6	6.0	Ω
I_S	Maximum Continuous Drain-Source Diode Forward Current			0.38		A
I_{SM}	Maximum Pulsed Continuous Drain-Source Diode Forward Current			3.04		A
V_{SD}	Drain-Source Diode Forward Voltage	$V_{GS}=0V$, $I_S=0.38A$			1.2	V

Typical Performance Characteristics

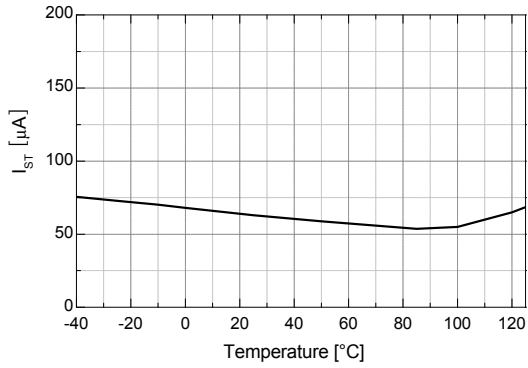

Figure 5. Startup Current vs. Temperature

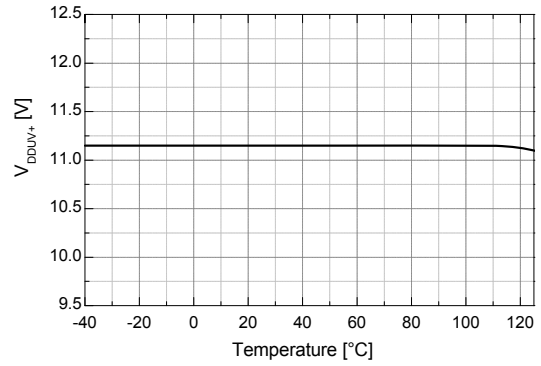

Figure 6. V_{DD} UVLO+ vs. Temperature

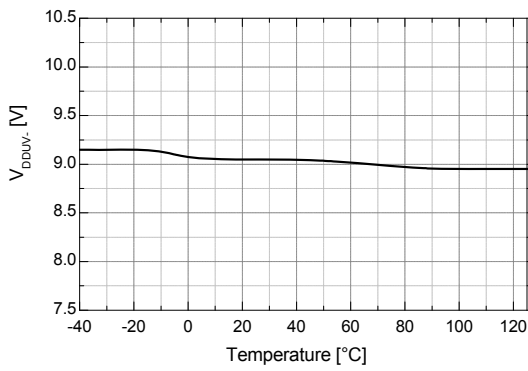

Figure 7. V_{DD} UVLO- vs. Temperature

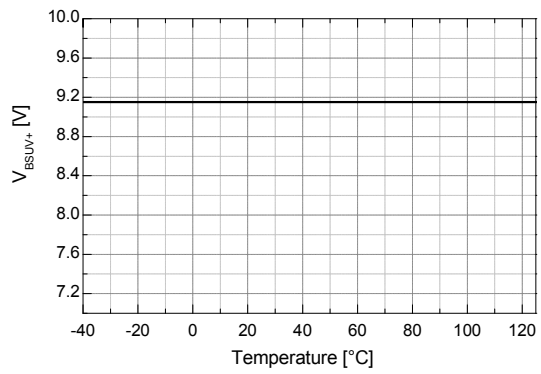

Figure 8. $V_{B.V_{OUT}}$ UVLO+ vs. Temperature

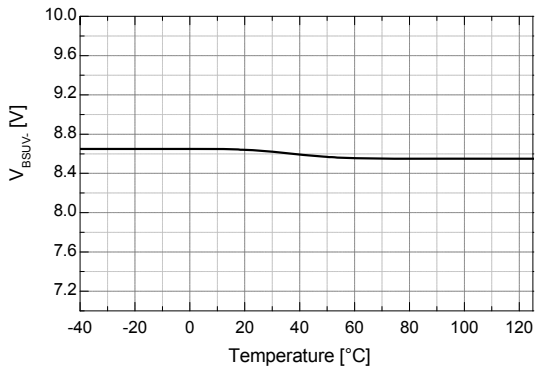

Figure 9. $V_{B.V_{OUT}}$ UVLO- vs. Temperature

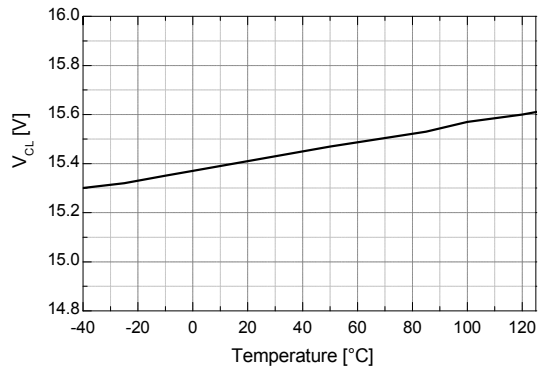

Figure 10. V_{CL} vs. Temperature

Typical Performance Characteristics (Continued)

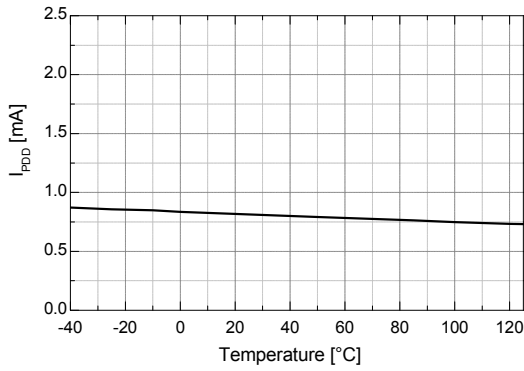

Figure 11. I_{PDD} vs. Temperature

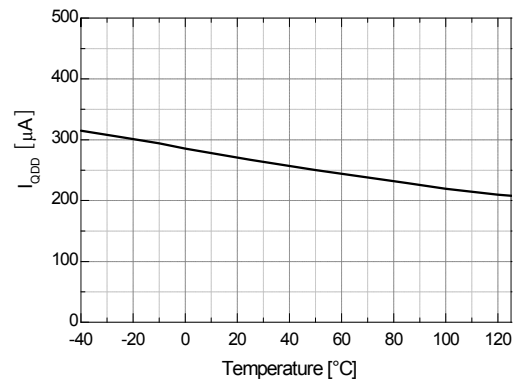

Figure 12. I_{QDD} vs. Temperature

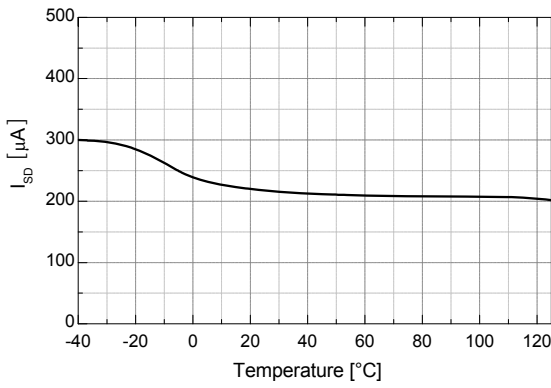

Figure 13. I_{SD} vs. Temperature

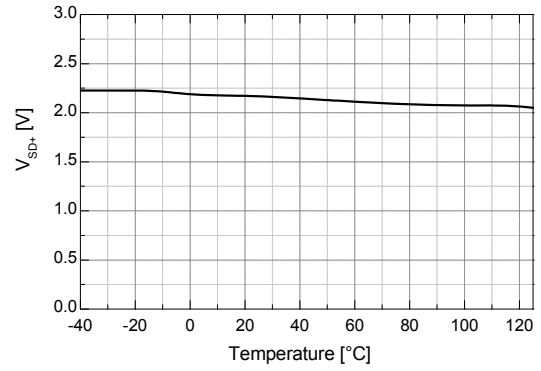

Figure 14. V_{SD+} vs. Temperature

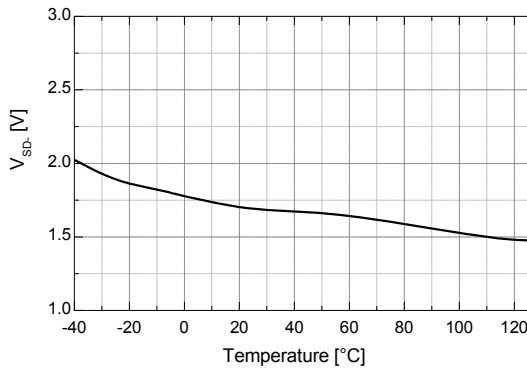

Figure 15. V_{SD-} vs. Temperature

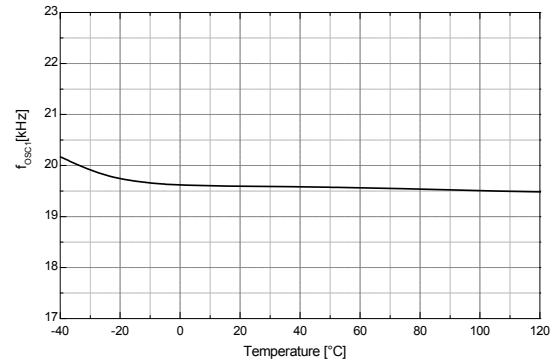

Figure 16. Operating Frequency vs. Temperature

Typical Performance Characteristics (Continued)

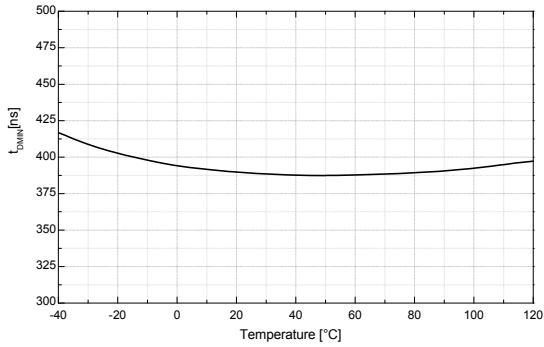

Figure 17. $t_{D\text{MIN}}$ vs. Temperature

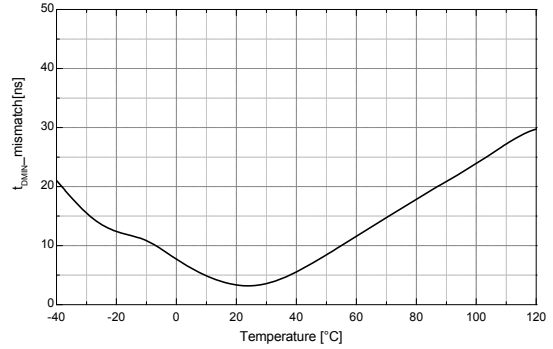

Figure 18. Dead-Time Mismatch vs. Temperature

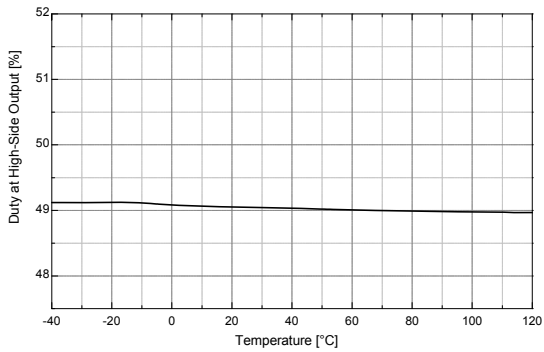

Figure 19. High-Side Duty Ratio vs. Temperature

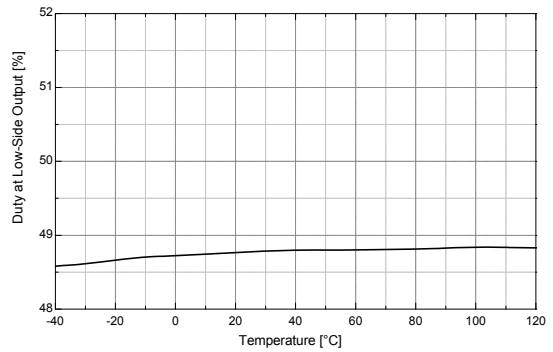

Figure 20. Low-Side Duty Ratio vs. Temperature

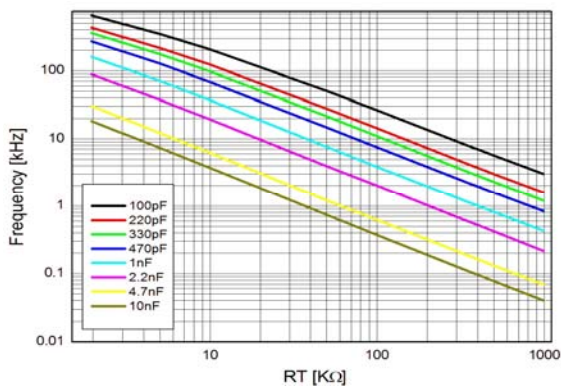

Figure 21. Frequency vs. R_T

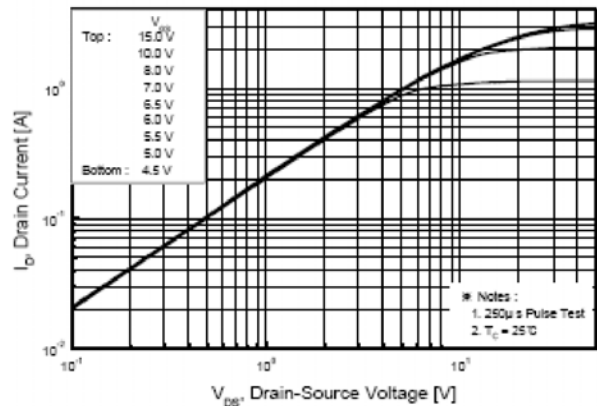

Figure 22. On-Region Characteristics

Typical Performance Characteristics (Continued)

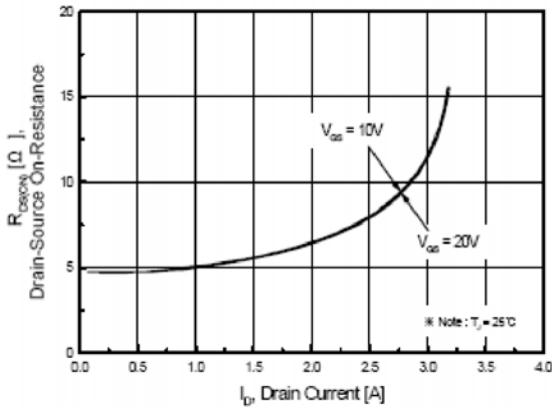

Figure 23. On-Resistance Variation vs. Drain Current and Gate Voltage

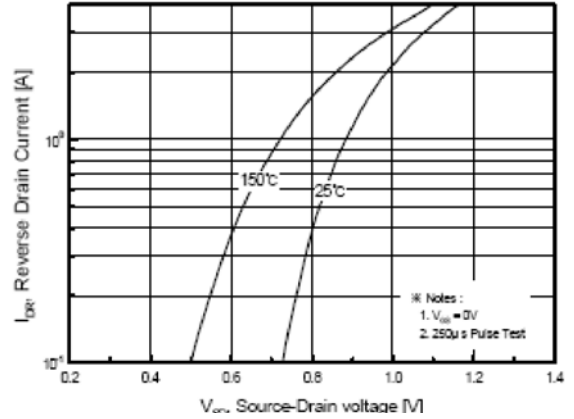

Figure 24. Body Diode Forward Voltage Variation vs. Source Current and Temperature

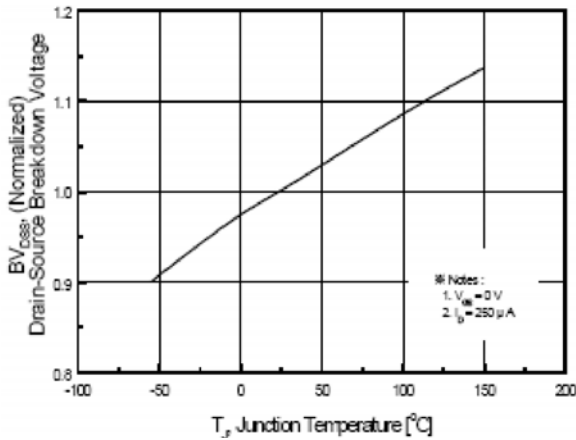

Figure 25. Breakdown Voltage Variation vs. Temperature

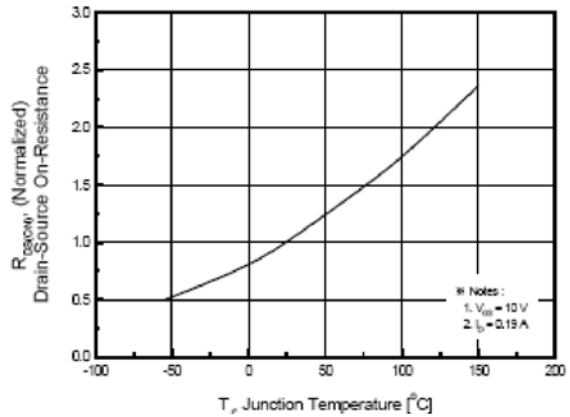

Figure 26. On-Resistance Variation vs. Temperature

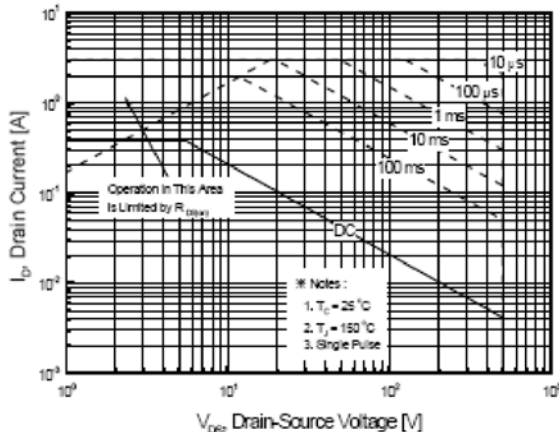

Figure 27. Maximum Safe Operating Area

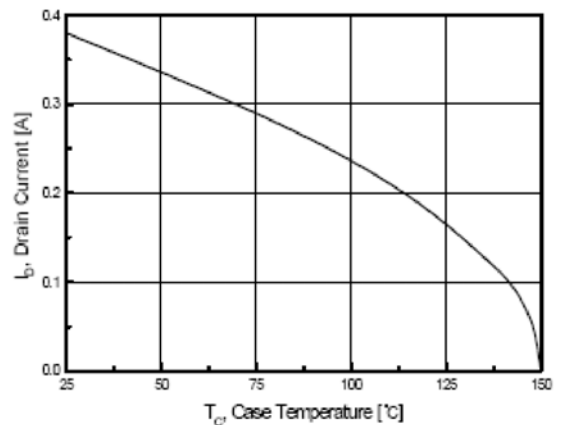

Figure 28. Maximum Drain-Current vs. Case Temperature

Application Information

1. Under-Voltage Lockout (UVLO) Function

FAN7387V has a UVLO circuit for a low-side and high-side block. When V_{DD} reaches to the $V_{DD_{UV+}}$, the UVLO circuit is released and the FAN7387V operates normally. At UVLO condition, the FAN7387V has a low supply current of less than $130\mu A$. Once UVLO is released, FAN7387V operates normally until V_{DD} goes below $V_{DD_{UV-}}$, the UVLO hysteresis. FAN7387V also has a high-side gate driver. The supply for the high-side driver is applied between VB and V_{OUT} . To prevent malfunction at low supply voltage between VB and V_{OUT} , FAN7387V provides an additional UVLO circuit. If $V_{B-V_{OUT}}$ is under V_{HSUV+} , the driver holds LOW state to turn off the high-side switch. Once the voltage of $V_{B-V_{OUT}}$ is higher than V_{HSUV+} , after $V_{B-V_{OUT}}$ exceeds V_{HSUV-} , the operation of driver resumes.

2. Oscillator

The running frequency is determined by an external timing resistor (R_T) and timing capacitor (C_T). The charge time of capacitor C_T from $1/4 V_{DD}$ to V_{DD} determines the running frequency of gate driver output (V_{OUT}).

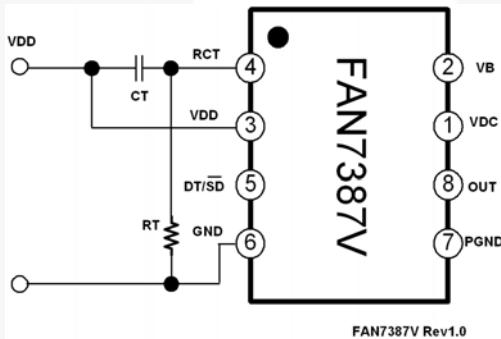

Figure 29. Typical Connection Method

Figure 30 shows the typical waveforms of RCT and internal signals (LO and HO) of IC. From the circuit analysis, the discharging time of RCT, t , is given by:

$$V_{RCT}(t) = V_{DD} \times \ln\left(\frac{-t}{R_T \cdot C_T}\right) \quad (1)$$

From Equation 1, it is possible to calculate the discharging time, t , from V_{DD} to one quarter ($1/4$) of V_{DD} by substituting $V_{RCT}(t)$ with $1/4 V_{DD}$.

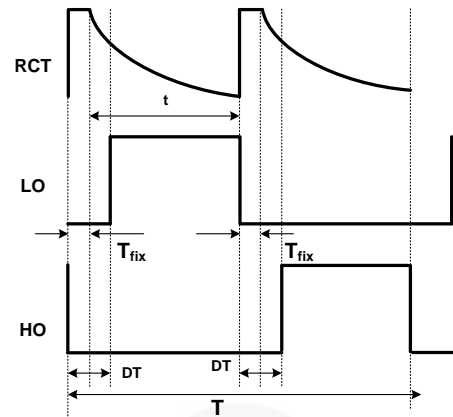

Figure 30. Typical Waveforms of RCT and Internal Signal (LO, HO) of IC

$$t = 1.38 \cdot R_T \cdot C_T \quad (2)$$

The running frequency of IC is determined by $1/t$ and is approximately given as:

$$f_{\text{running}} = \frac{1}{t} = \frac{1}{2(t + t_{\text{fix}})} \quad (3)$$

where t is the discharging time of the RCT voltage and t_{fix} is constant value about 450ns of IC.

3. Programming Dead Time Control / Shutdown

A multi-function pin controls dead time using an external resistor (R_{DT}) and protects abnormal condition using an external switch. This pin should be connected to an external capacitor to maintain stable operation.

If the voltage of DT/SD is decreased to under 1V by an external switch, such as the TR or MOSFET, the FAN7387V enters shutdown mode. In this mode, the FAN7387V doesn't have any output signal.

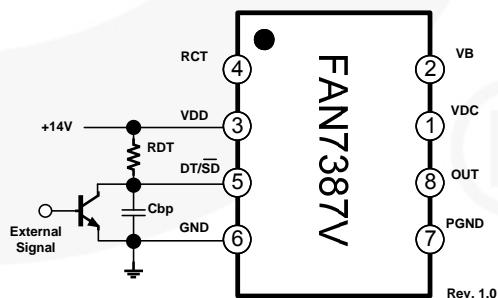
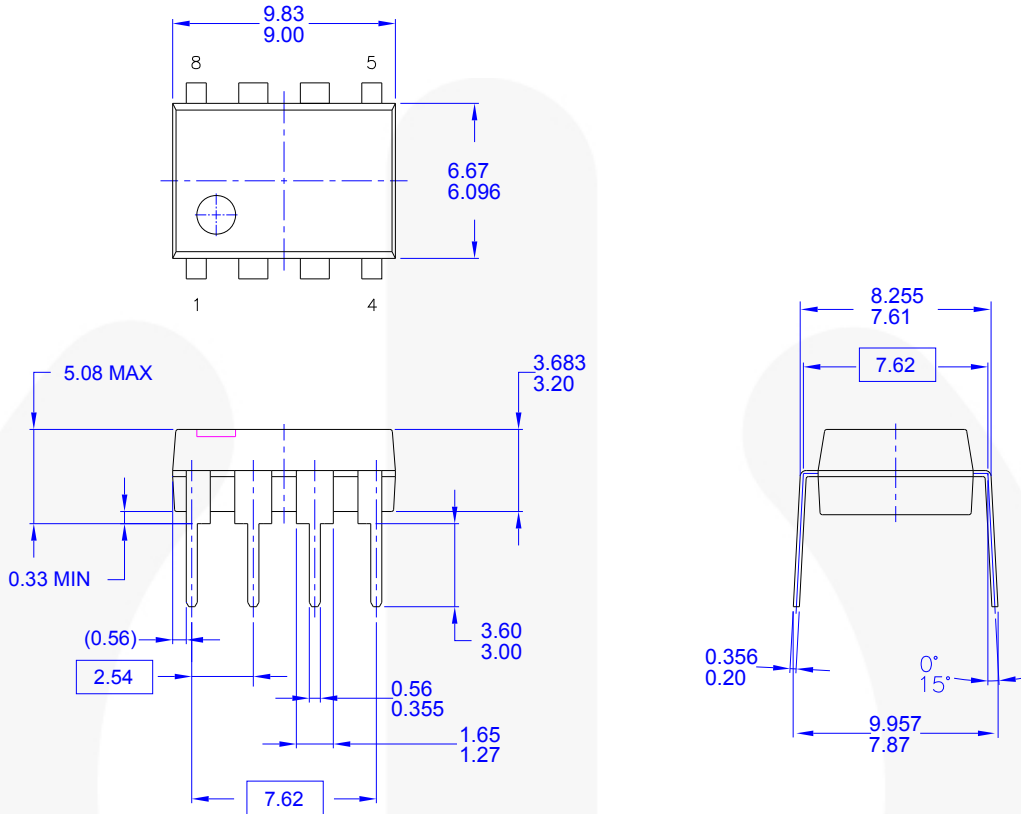

Figure 31. External Shutdown Circuit

Physical Dimensions



- NOTES: UNLESS OTHERWISE SPECIFIED
- THIS PACKAGE CONFORMS TO JEDEC MS-001 VARIATION BA
 - ALL DIMENSIONS ARE IN MILLIMETERS.
 - DIMENSIONS ARE EXCLUSIVE OF BURRS, MOLD FLASH, AND TIE BAR EXTRUSIONS.
 - DIMENSIONS AND TOLERANCES PER ASME Y14.5M-1994
 - DRAWING FILENAME AND REVISION: MKT-N08FREV2.

Figure 32. 8-Lead Dual In-line Package (DIP)



Package drawings are provided as a service to customers considering Fairchild components. Drawings may change in any manner without notice. Please note the revision and/or date on the drawing and contact a Fairchild Semiconductor representative to verify or obtain the most recent revision. Package specifications do not expand the terms of Fairchild's worldwide terms and conditions, specifically the warranty therein, which covers Fairchild products.

Always visit Fairchild Semiconductor's online packaging area for the most recent package drawings:
<http://www.fairchildsemi.com/packaging/>.



TRADEMARKS

The following includes registered and unregistered trademarks and service marks, owned by Fairchild Semiconductor and/or its global subsidiaries, and is not intended to be an exhaustive list of all such trademarks.

- | | | | |
|--|--|--|---|
| 2Cool™ | F-PFS™ | PowerTrench® | The Power Franchise® |
| AccuPower™ | FRFET® | PowerXS™ | the power franchise |
| AX-CAP™* | Global Power Resource™ | Programmable Active Droop™ | TinyBoost™ |
| BitSiC™ | GreenBridge™ | QFET® | TinyBuck™ |
| Build it Now™ | Green FPS™ | QS™ | TinyCalc™ |
| CorePLUS™ | Green FPS™ e-Series™ | Quiet Series™ | TinyLogic® |
| CorePOWER™ | Gmax™ | RapidConfigure™ | TINYOPTO™ |
| CROSSVOLT™ | GTO™ |  ™ | TinyPower™ |
| CTL™ | IntelliMAX™ | Saving our world, 1mW/W/kW at a time™ | TinyPWM™ |
| Current Transfer Logic™ | ISOPLANAR™ | SignalWise™ | TinyWire™ |
| DEUXPEED® | Making Small Speakers Sound Louder and Better™ | SmartMax™ | TranSiC™ |
| Dual Cool™ | MegaBuck™ | SMART START™ | TriFault Detect™ |
| EcoSPARK® | MICROCOUPLER™ | Solutions for Your Success™ | TRUECURRENT®* |
| EfficientMax™ | MicroFET™ | SPM® | µSerDes™ |
| ESBC™ | MicroPak™ | STEALTH™ |  SerDes™ |
|  Fairchild® | MicroPak2™ | SuperFET® | UHC® |
| Fairchild Semiconductor® | MillerDrive™ | SuperSOT™-3 | Ultra FRFET™ |
| FACT Quiet Series™ | MotionMax™ | SuperSOT™-6 | UniFET™ |
| FACT® | Motion-SPM™ | SuperSOT™-8 | VCM™ |
| FAST® | mWSaver™ | SupreMOS® | VisualMax™ |
| FastvCore™ | OptoHiT™ | SyncFET™ | VoltagePlus™ |
| FETBench™ | OPTOLOGIC® | Sync-Lock™ | XS™ |
| FlashWriter®* | OPTOPLANAR® |  SYSTEM GENERAL®* | |
| FPS™ | | | |

* Trademarks of System General Corporation, used under license by Fairchild Semiconductor.

DISCLAIMER

FAIRCHILD SEMICONDUCTOR RESERVES THE RIGHT TO MAKE CHANGES WITHOUT FURTHER NOTICE TO ANY PRODUCTS HEREIN TO IMPROVE RELIABILITY, FUNCTION, OR DESIGN. FAIRCHILD DOES NOT ASSUME ANY LIABILITY ARISING OUT OF THE APPLICATION OR USE OF ANY PRODUCT OR CIRCUIT DESCRIBED HEREIN; NEITHER DOES IT CONVEY ANY LICENSE UNDER ITS PATENT RIGHTS, NOR THE RIGHTS OF OTHERS. THESE SPECIFICATIONS DO NOT EXPAND THE TERMS OF FAIRCHILD'S WORLDWIDE TERMS AND CONDITIONS, SPECIFICALLY THE WARRANTY THEREIN, WHICH COVERS THESE PRODUCTS.

LIFE SUPPORT POLICY

FAIRCHILD'S PRODUCTS ARE NOT AUTHORIZED FOR USE AS CRITICAL COMPONENTS IN LIFE SUPPORT DEVICES OR SYSTEMS WITHOUT THE EXPRESS WRITTEN APPROVAL OF FAIRCHILD SEMICONDUCTOR CORPORATION.

As used herein:

1. Life support devices or systems are devices or systems which, (a) are intended for surgical implant into the body or (b) support or sustain life, and (c) whose failure to perform when properly used in accordance with instructions for use provided in the labeling, can be reasonably expected to result in a significant injury of the user.
2. A critical component in any component of a life support, device, or system whose failure to perform can be reasonably expected to cause the failure of the life support device or system, or to affect its safety or effectiveness.

ANTI-COUNTERFEITING POLICY

Fairchild Semiconductor Corporation's Anti-Counterfeiting Policy. Fairchild's Anti-Counterfeiting Policy is also stated on our external website, www.fairchildsemi.com, under Sales Support.

Counterfeiting of semiconductor parts is a growing problem in the industry. All manufacturers of semiconductor products are experiencing counterfeiting of their parts. Customers who inadvertently purchase counterfeit parts experience many problems such as loss of brand reputation, substandard performance, failed applications, and increased cost of production and manufacturing delays. Fairchild is taking strong measures to protect ourselves and our customers from the proliferation of counterfeit parts. Fairchild strongly encourages customers to purchase Fairchild parts either directly from Fairchild or from Authorized Fairchild Distributors who are listed by country on our web page cited above. Products customers buy either from Fairchild directly or from Authorized Fairchild Distributors are genuine parts, have full traceability, meet Fairchild's quality standards for handling and storage and provide access to Fairchild's full range of up-to-date technical and product information. Fairchild and our Authorized Distributors will stand behind all warranties and will appropriately address any warranty issues that may arise. Fairchild will not provide any warranty coverage or other assistance for parts bought from Unauthorized Sources. Fairchild is committed to combat this global problem and encourage our customers to do their part in stopping this practice by buying direct or from authorized distributors.

PRODUCT STATUS DEFINITIONS

Definition of Terms

Datasheet Identification	Product Status	Definition
Advance Information	Formative / In Design	Datasheet contains the design specifications for product development. Specifications may change in any manner without notice.
Preliminary	First Production	Datasheet contains preliminary data; supplementary data will be published at a later date. Fairchild Semiconductor reserves the right to make changes at any time without notice to improve design.
No Identification Needed	Full Production	Datasheet contains final specifications. Fairchild Semiconductor reserves the right to make changes at any time without notice to improve the design.
Obsolete	Not In Production	Datasheet contains specifications on a product that is discontinued by Fairchild Semiconductor. The datasheet is for reference information only.

Rev. I61

ON Semiconductor and  are trademarks of Semiconductor Components Industries, LLC dba ON Semiconductor or its subsidiaries in the United States and/or other countries. ON Semiconductor owns the rights to a number of patents, trademarks, copyrights, trade secrets, and other intellectual property. A listing of ON Semiconductor's product/patent coverage may be accessed at www.onsemi.com/site/pdf/Patent-Marking.pdf. ON Semiconductor reserves the right to make changes without further notice to any products herein. ON Semiconductor makes no warranty, representation or guarantee regarding the suitability of its products for any particular purpose, nor does ON Semiconductor assume any liability arising out of the application or use of any product or circuit, and specifically disclaims any and all liability, including without limitation special, consequential or incidental damages. Buyer is responsible for its products and applications using ON Semiconductor products, including compliance with all laws, regulations and safety requirements or standards, regardless of any support or applications information provided by ON Semiconductor. "Typical" parameters which may be provided in ON Semiconductor data sheets and/or specifications can and do vary in different applications and actual performance may vary over time. All operating parameters, including "Typicals" must be validated for each customer application by customer's technical experts. ON Semiconductor does not convey any license under its patent rights nor the rights of others. ON Semiconductor products are not designed, intended, or authorized for use as a critical component in life support systems or any FDA Class 3 medical devices or medical devices with a same or similar classification in a foreign jurisdiction or any devices intended for implantation in the human body. Should Buyer purchase or use ON Semiconductor products for any such unintended or unauthorized application, Buyer shall indemnify and hold ON Semiconductor and its officers, employees, subsidiaries, affiliates, and distributors harmless against all claims, costs, damages, and expenses, and reasonable attorney fees arising out of, directly or indirectly, any claim of personal injury or death associated with such unintended or unauthorized use, even if such claim alleges that ON Semiconductor was negligent regarding the design or manufacture of the part. ON Semiconductor is an Equal Opportunity/Affirmative Action Employer. This literature is subject to all applicable copyright laws and is not for resale in any manner.

PUBLICATION ORDERING INFORMATION

LITERATURE FULFILLMENT:

Literature Distribution Center for ON Semiconductor
19521 E. 32nd Pkwy, Aurora, Colorado 80011 USA
Phone: 303-675-2175 or 800-344-3860 Toll Free USA/Canada
Fax: 303-675-2176 or 800-344-3867 Toll Free USA/Canada
Email: orderlit@onsemi.com

N. American Technical Support: 800-282-9855 Toll Free
USA/Canada
Europe, Middle East and Africa Technical Support:
Phone: 421 33 790 2910
Japan Customer Focus Center
Phone: 81-3-5817-1050

ON Semiconductor Website: www.onsemi.com
Order Literature: <http://www.onsemi.com/orderlit>
For additional information, please contact your local
Sales Representative