

features

- Multi-Rate Operation from 155 Mbps Up To 3.3 Gbps
- 106-mW Power Consumption
- Input Offset Cancellation
- High Input Dynamic Range
- Output Disable
- Output Polarity Select
- CML Data Outputs
- Receive Signal Strength Indicator (RSSI)
- Loss of Signal Detection

- Single 3.3-V Supply
- Surface Mount Small Footprint 3 mm × 3 mm 16-Pin QFN Package

applications

- SONET/SDH Transmission Systems at OC3, OC12, OC24, OC48
- 1.0625-Gbps and 2.125-Gbps Fibre Channel Receivers
- Gigabit Ethernet Receivers

description

The ONET3301PA is a versatile high-speed limiting amplifier for multiple fiber optic applications with data rates up to 3.3 Gbps.

This device provides a gain of about 50 dB, which ensures a fully differential output swing for input signals as low as 3 mV_{p-p}.

The high input signal dynamic range ensures low jitter output signals even when overdriven with input signal swings as high as 1200 mV_{p-p}.

The ONET3301PA includes loss of signal detection, as well as a received signal strength indicator.

The ONET3301PA is available in a small footprint 3 mm × 3 mm 16-pin QFN package and requires a single 3.3-V supply.

This power efficient limiting amplifier typically dissipates less than 106 mW. It is characterized for operation from –40°C to 85°C.



Please be aware that an important notice concerning availability, standard warranty, and use in critical applications of Texas Instruments semiconductor products and disclaimers thereto appears at the end of this data sheet.

PRODUCTION DATA information is current as of publication date. Products conform to specifications per the terms of Texas Instruments standard warranty. Production processing does not necessarily include testing of all parameters.



ONET3301PA 155-Mbps TO 3.3-Gbps LIMITING AMPLIFIER

SLLS603C – MARCH 2004 – REVISED OCTOBER 2005

block diagram

A simplified block diagram of the ONET3301PA is shown in Figure 1.

This compact, low power 3.3-Gbps limiting amplifier consists of a high-speed data path with offset cancellation block, a loss of signal and RSSI detection block, and a bandgap voltage reference and bias current generation block.

The limiting amplifier requires a single 3.3-V supply voltage. All circuit parts are described in detail below.

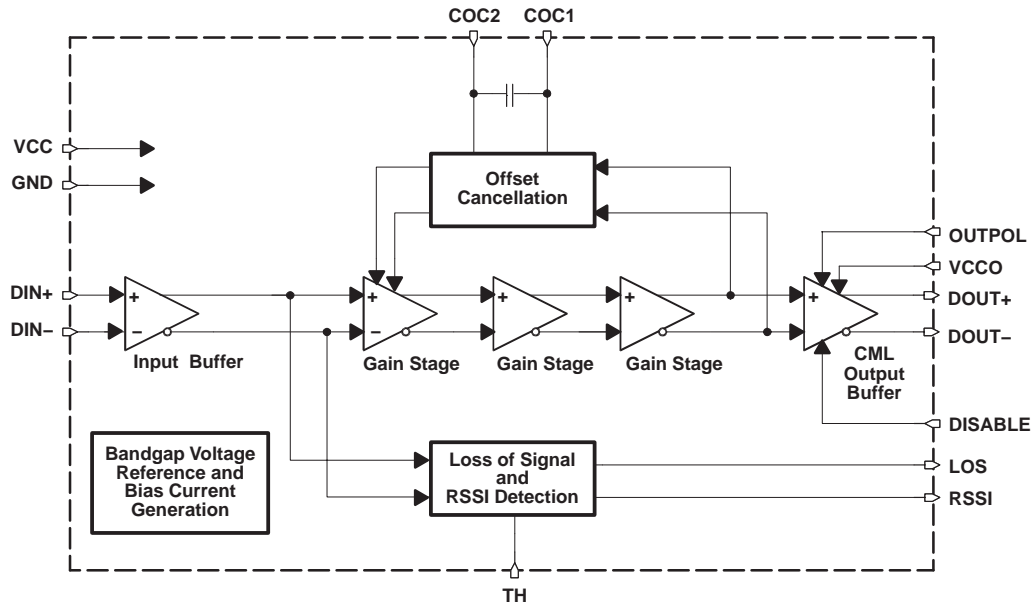

Figure 1. Block Diagram

high-speed data path

The high-speed data signal is applied to the data path by means of the input signal pins DIN+/DIN-. The data path consists of the input stage with $2 \times 50\text{-}\Omega$ on-chip line termination to VCC, three gain stages, which provide the required typical gain of about 50 dB and a CML output stage. The amplified data output signal is available at the output pins DOUT+/DOUT-, which provide $2 \times 50\text{-}\Omega$ back-termination to VCCO. The output stage also includes a data polarity switching function, which is controlled by the OUTPOL input and a disable function, controlled by the signal applied to the DISABLE input pin.

An offset cancellation compensates inevitable internal offset voltages and thus ensures proper operation even for small input data signals.

The low frequency cutoff is as low as 45 kHz with the built-in filter capacitor.

For applications, which require even lower cutoff frequencies, an additional external filter capacitor may be connected to the COC1/COC2 pins.

loss of signal and RSSI detection

The output signal of the input buffer is monitored by the loss of signal and RSSI detection circuitry. In this block a signal is generated, which is linearly proportional to the input amplitude over a wide input voltage range. This signal is available at the RSSI output pin.

Furthermore, this circuit block compares the input signal to a threshold, which can be programmed by means of an external resistor connected to the TH pin. If the input signal falls below the specified threshold, a loss of signal is indicated at the LOS pin.

The relation between the LOS assert voltage V_{AST} (in mV_{p-p}) and the external resistor R_{TH} (in $k\Omega$) connected to the TH pin can be approximated as given below:

$$R_{TH} \approx \frac{43 \text{ k}\Omega}{V_{AST} / mV_{p-p}} - 600 \Omega \quad (1)$$

$$V_{AST} \approx \frac{43 \text{ mV}_{p-p}}{R_{TH} / k\Omega + 0.6} \quad (2)$$

bandgap voltage and bias generation

The ONET3301PA limiting amplifier is supplied by a single 3.3-V $\pm 10\%$ supply voltage connected to the VCC and VCCO pins. This voltage is referred to ground (GND).

An on-chip bandgap voltage circuitry generates a supply voltage independent reference from which all other internally required voltages and bias currents are derived.

package

For the ONET3301PA, a small footprint 3 mm \times 3 mm 16-pin QFN package is used with a lead pitch of 0,5 mm. The pin out is shown in Figure 2.

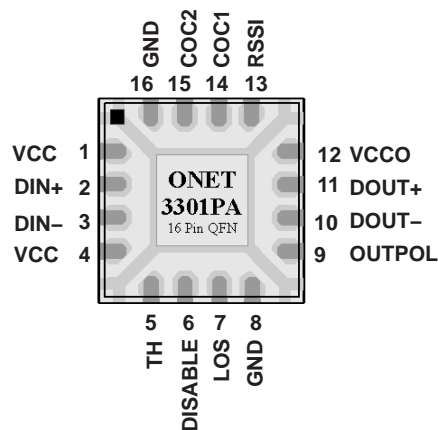

Figure 2. Pinout of ONET3301PA in a 3 mm \times 3 mm 16-Pin QFN Package (Top View)

ONET3301PA

155-Mbps TO 3.3-Gbps LIMITING AMPLIFIER

SLLS603C – MARCH 2004 – REVISED OCTOBER 2005

terminal functions

The following table shows a pin description for the ONET3301PA in a 3 mm x 3 mm 16-pin QFN package.

TERMINAL		TYPE	DESCRIPTION
NAME	NO.		
VCC	1, 4	Supply	3.3-V \pm 10% supply voltage
DIN+	2	Analog in	Noninverted data input. On-chip 50- Ω terminated to VCC
DIN-	3	Analog in	Inverted data input. On-chip 50- Ω terminated to VCC
TH	5	Analog in	LOS threshold adjustment with resistor to GND.
DISABLE	6	CMOS in	Disables CML output stage when set to high level.
LOS	7	CMOS out	High level indicates that the input signal amplitude is below the programmed threshold level.
GND	8, 16, EP	Supply	Circuit ground. Exposed die pad (EP) must be grounded.
OUTPOL	9	CMOS in	Output data signal polarity select (internally pulled up): Setting to high level or leaving pin open selects normal polarity. Low level selects inverted polarity.
DOUT-	10	CML out	Inverted data output. On-chip 50- Ω back-terminated to VCCO
DOUT+	11	CML out	Noninverted data output. On-chip 50- Ω back-terminated to VCCO
VCCO	12	Supply	3.3-V \pm 10% supply voltage for output stage
RSSI	13	Analog out	Analog output voltage proportional to the input data amplitude. Indicates the strength of the received signal (RSSI).
COC1	14	Analog	Offset cancellation filter capacitor terminal 1. Connect an additional filter capacitor between this pin and COC2 (pin 15). To disable the offset cancellation loop connect COC1 and COC2 (pins 14 and 15).
COC2	15	Analog	Offset cancellation filter capacitor terminal 2. Connect an additional filter capacitor between this pin and COC1 (pin 14). To disable the offset cancellation loop connect COC1 and COC2 (pins 14 and 15).

absolute maximum ratings

over operating free-air temperature range unless otherwise noted[†]

		VALUE	UNIT
VCC, VCCO	Supply voltage, See Note 1	-0.3 to 4	V
VDIN+, VDIN-	Voltage at DIN+, DIN-, See Note 1	0.5 to 4	V
VTH, VDISABLE, VLOS, VOUTPOL, VDOUT+, VDOUT-, VRSSI, VCOC1, VCOC2	Voltage at TH, DISABLE, LOS, OUTPOL, DOUT+, DOUT-, RSSI, COC1, and COC2, See Note 1	-0.3 to 4	V
VCOC_DIFF	Differential voltage between COC1 and COC2	\pm 1	V
VDIN_DIFF	Differential voltage between DIN+ and DIN-	\pm 2.5	V
ILOS	Current into LOS	-1 to 9	mA
IDIN+, IDIN-, IDOUT+, IDOUT-	Continuous current at inputs and outputs	-25 to 25	mA
ESD	ESD rating at all pins	3	kV (HBM)
TJ(max)	Maximum junction temperature	125	°C
Tstg	Storage temperature range	-65 to 85	°C
TA	Characterized free-air operating temperature range	-40 to 85	°C
TL	Lead temperature 1,6 mm (1/16 inch) from case for 10 seconds	260	°C

[†] Stresses beyond those listed under "absolute maximum ratings" may cause permanent damage to the device. These are stress ratings only, and functional operation of the device at these or any other conditions beyond those indicated under "recommended operating conditions" is not implied. Exposure to absolute-maximum-rated conditions for extended periods may affect device reliability.

NOTE 1: All voltage values are with respect to network ground terminal.



recommended operating conditions

	MIN	TYP	MAX	UNIT
Supply voltage, V_{CC} , V_{CCO}	3	3.3	3.6	V
Operating free-air temperature, T_A	-40		85	°C

dc electrical characteristics

over recommended operating conditions (unless otherwise noted), typical operating condition is at $V_{CC} = 3.3$ V and $T_A = 25^\circ\text{C}$

PARAMETER	TEST CONDITIONS	MIN	TYP	MAX	UNIT
V_{CC}, V_{CCO} Supply voltage		3	3.3	3.6	V
I_{CC} Supply current	DISABLE = low (excludes CML output current)		32	40	mA
V_{OD} Differential data output voltage swing	DISABLE = high		0.25	10	mV _{p-p}
	DISABLE = low	600	780	1200	mV _{p-p}
r_{IN}, r_{OUT} Data input/output resistance	Single ended		50		Ω
RSSI output voltage	Input = 2 mV _{p-p} , $R_{RSSI} \geq 10$ k Ω		100		mV
	Input = 80 mV _{p-p} , $R_{RSSI} \geq 10$ k Ω		2800		
RSSI linearity	20-dB input signal, $V_{IN} \leq 80$ mVpp		$\pm 3\%$	$\pm 8\%$	
$V_{(IN_MIN)}$ Data input sensitivity	BER < 10^{-10}		3	5	mV _{p-p}
$V_{(IN_MAX)}$ Data input overload		1200			mV _{p-p}
CMOS input high voltage		2.1			V
CMOS input low voltage				0.6	V
LOS high voltage	$I_{SINK} = -30$ μ A	2.4			V
LOS low voltage	$I_{SOURCE} = 1$ mA			0.4	V
LOS hysteresis	$2^{23}-1$ PRBS (at 2.5 Gbps and 155 Mbps)	2.5	4.5		dB
V_{TH} LOS assert threshold range	$2^{23}-1$ PRBS (at 2.5 Gbps and 155 Mbps)		5-40		mV _{p-p}

ac electrical characteristics

over recommended operating conditions (unless otherwise noted), typical operating condition is at $V_{CC} = 3.3$ V and $T_A = 25^\circ\text{C}$

PARAMETER	TEST CONDITIONS	MIN	TYP	MAX	UNIT
Low frequency -3-dB bandwidth	COC = open		45	70	kHz
	COC = 100 nF		0.8		
Data rate		3.3			Gb/s
v_{NI} Input referred noise			180		μ V _{RMS}
DJ Deterministic jitter, See Note 2	K28.5 pattern at 3.3 Gbps		8.5	25	ps _{p-p}
	$2^{23}-1$ PRBS equivalent pattern at 2.7 Gbps		9.3	30	
	K28.5 pattern at 2.1 Gbps		7.8	25	
	$2^{23}-1$ PRBS equivalent pattern at 155 Mbps		25	50	
RJ Random jitter	Input = 5 mVpp		6.5		ps _{RMS}
	Input = 10 mVpp		3		
t_r Output rise time	20% to 80%		60	85	ps
t_f Output fall time	20% to 80%		60	85	ps
PSNR Power supply noise rejection	$f < 2$ MHz	26			dB
t_{DIS} Disable response time			20		ns
t_{LOS} LOS assert/deassert time		2		100	μ s

NOTE 2: Deterministic jitter does not include pulse-width distortion due to residual small output offset voltage.

ONET3301PA
155-Mbps TO 3.3-Gbps LIMITING AMPLIFIER

SLLS603C – MARCH 2004 – REVISED OCTOBER 2005

APPLICATION INFORMATION

Figure 3 shows the ONET3301PA connected with an ac-coupled interface to the data signal source as well as to the output load.

Besides the ac-coupling capacitors, C_1 through C_4 in the input and output data signal lines, the only required external component is the LOS threshold setting resistor R_{TH} . In addition, an optional external filter capacitor (C_{OC}) may be used if a lower cutoff frequency is desired.

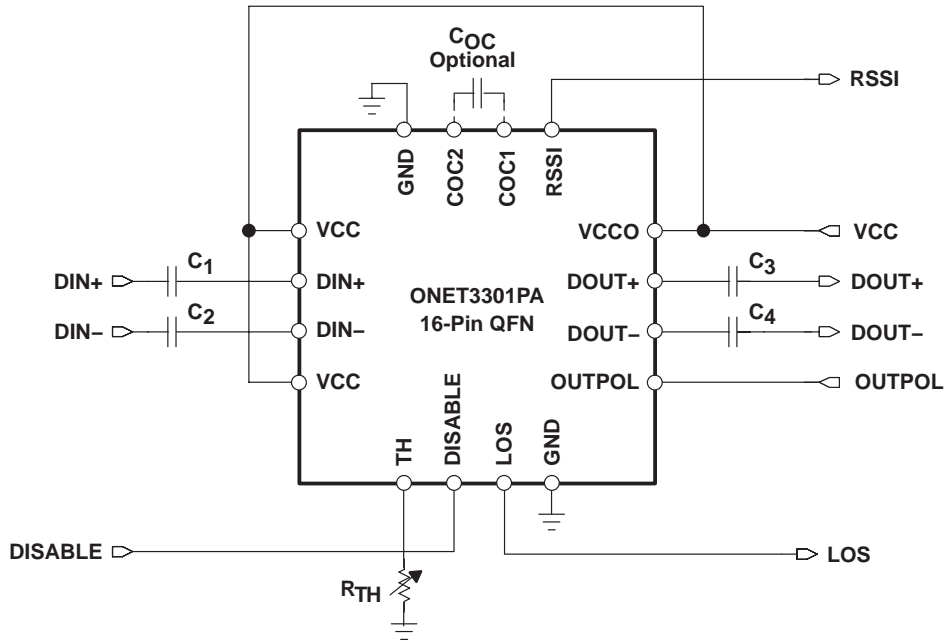
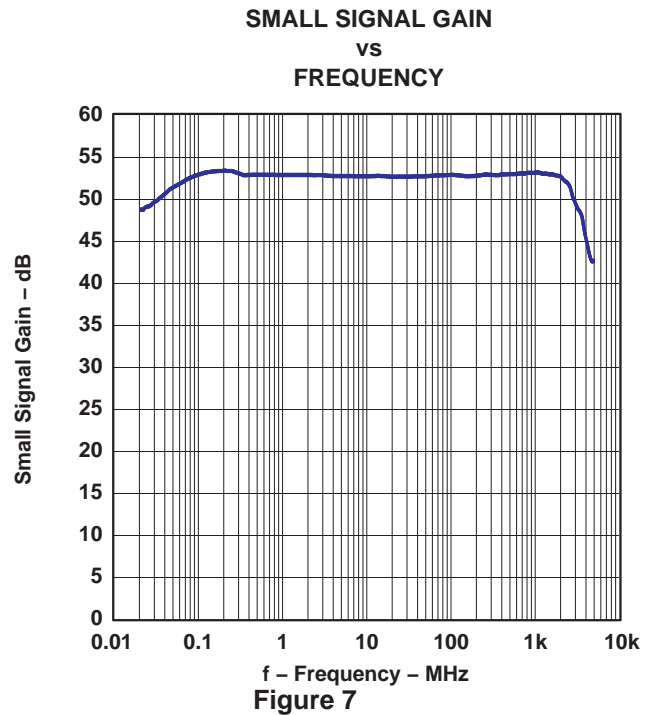
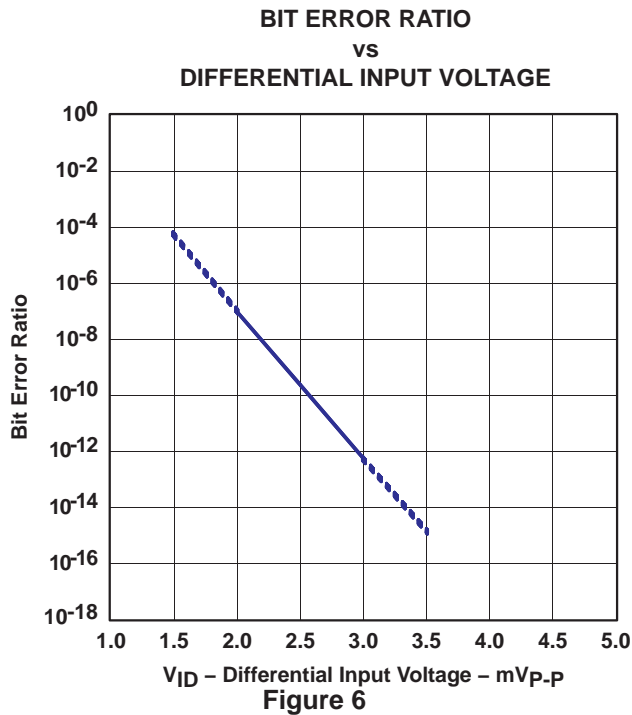
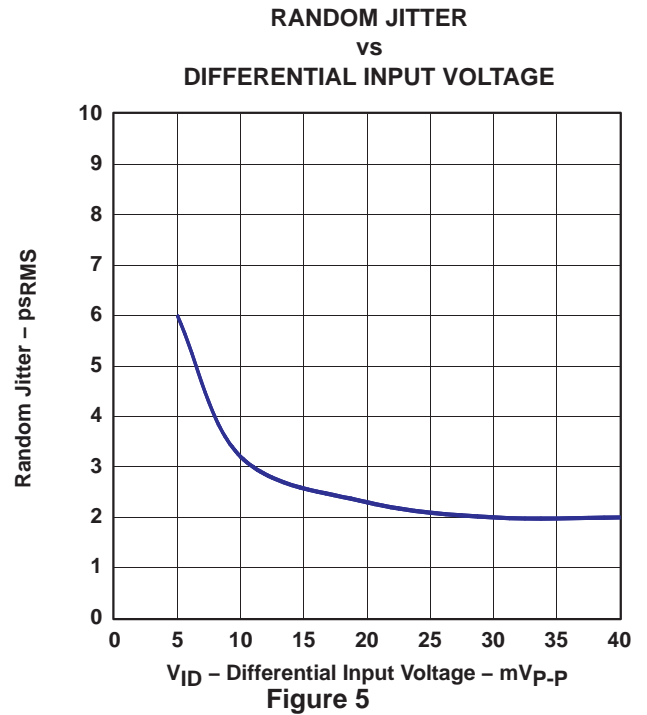
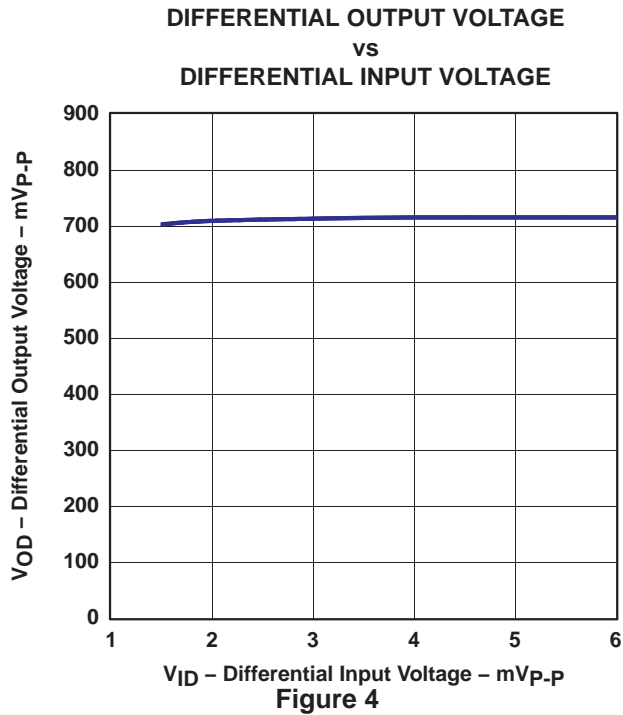
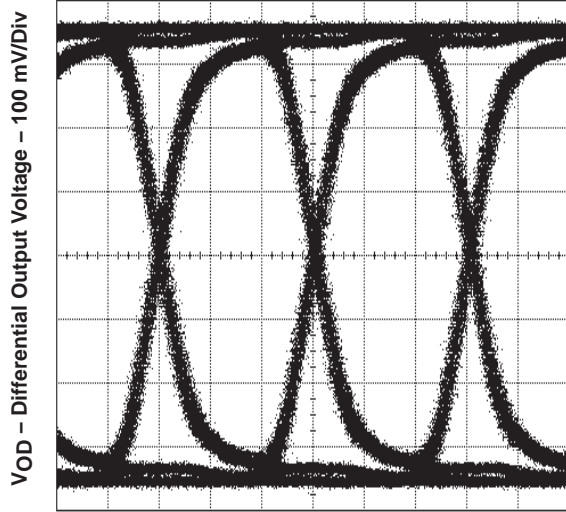

Figure 3. Basic Application Circuit With AC-Coupled I/Os



**OUTPUT EYE-DIAGRAM AT 3.3 GBPS AND
MINIMUM INPUT VOLTAGE (5 mV_{p-p})**



t - Time - 100 ps/Div

Figure 8

**OUTPUT EYE-DIAGRAM AT 3.3 GBPS AND
MAXIMUM INPUT VOLTAGE (1200 mV_{p-p})**

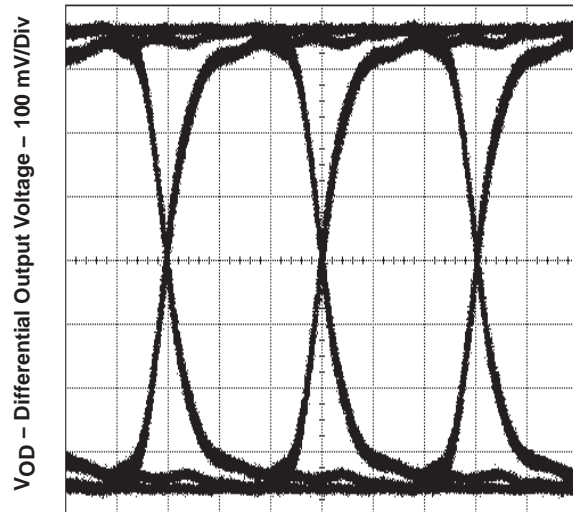

t - Time - 100 ps/Div

Figure 9

**OUTPUT EYE-DIAGRAM AT
3.3 GBPS, 85°C, AND MINIMUM
INPUT VOLTAGE (5 mV_{p-p})**

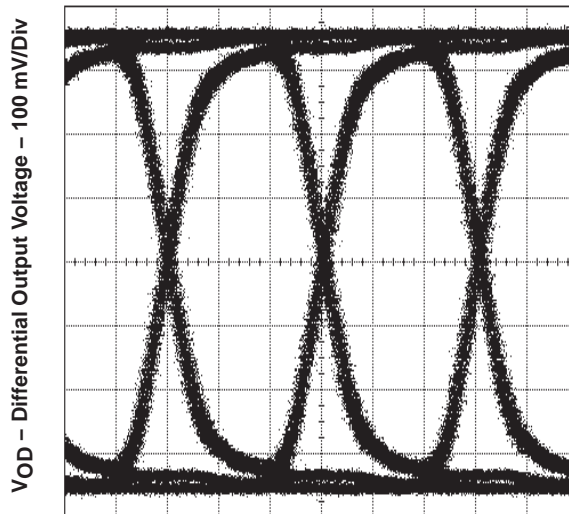

t - Time - 100 ps/Div

Figure 10

**OUTPUT EYE-DIAGRAM AT 2.5 GBPS AND
 MINIMUM INPUT VOLTAGE (5 mV_{p-p})**

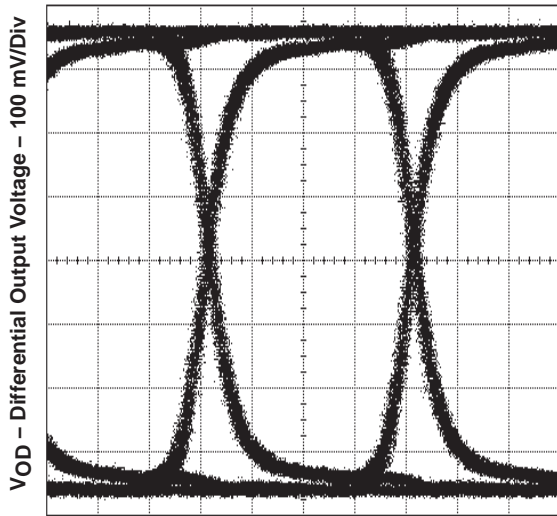

t – Time – 100 ps/Div

Figure 11

**OUTPUT EYE-DIAGRAM AT 2.5 GBPS AND
 MAXIMUM INPUT VOLTAGE (1200 mV_{p-p})**

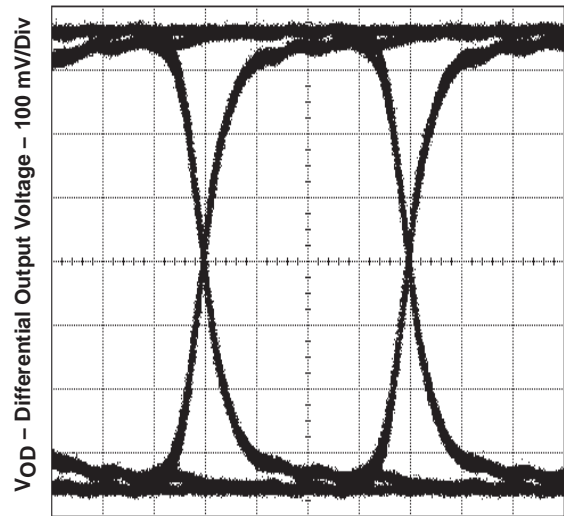

t – Time – 100 ps/Div

Figure 12

**LOS ASSERT/DEASSERT VOLTAGE
 VS
 EXTERNAL RESISTANCE R_{TH}**

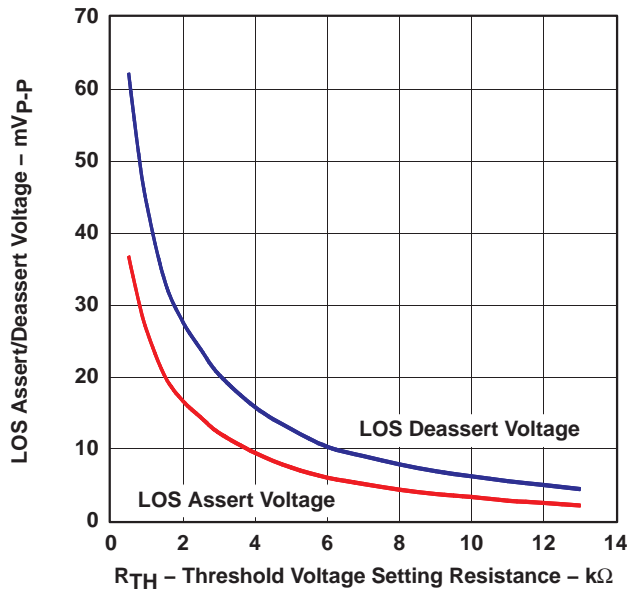

Figure 13

**DIFFERENTIAL INPUT RETURN GAIN
 VS
 FREQUENCY**

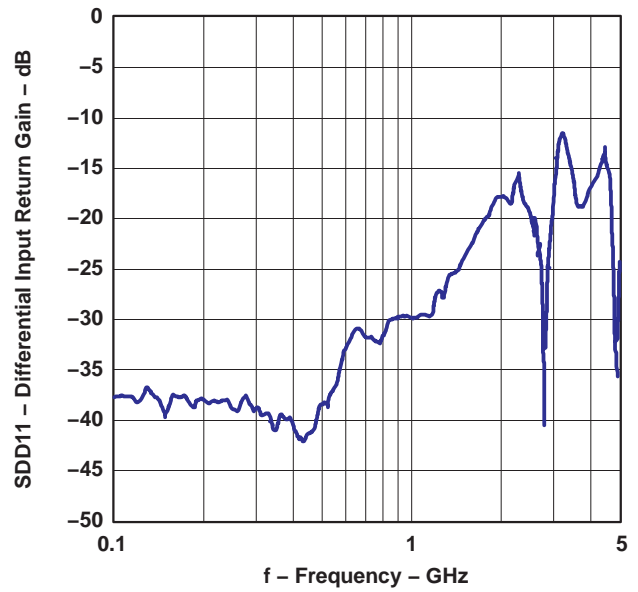

Figure 14

ONET3301PA 155-Mbps TO 3.3-Gbps LIMITING AMPLIFIER

SLLS603C – MARCH 2004 – REVISED OCTOBER 2005

DIFFERENTIAL OUTPUT RETURN GAIN
VS
FREQUENCY

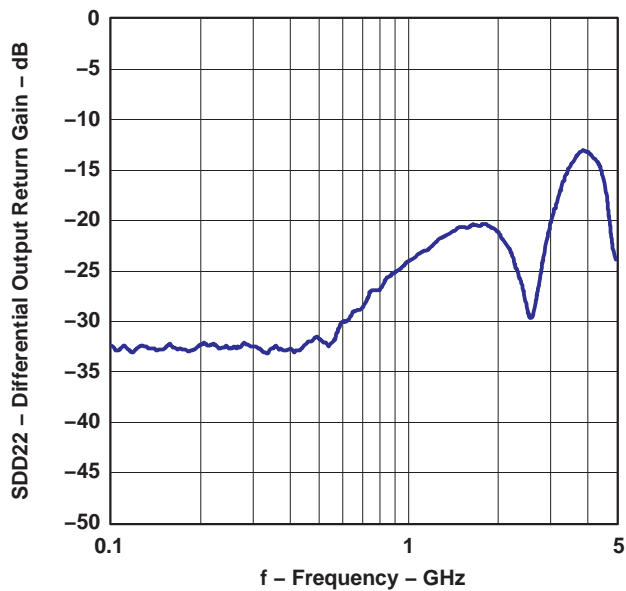

Figure 15

RECEIVE SIGNAL STRENGTH INDICATOR
VS
DIFFERENTIAL INPUT VOLTAGE

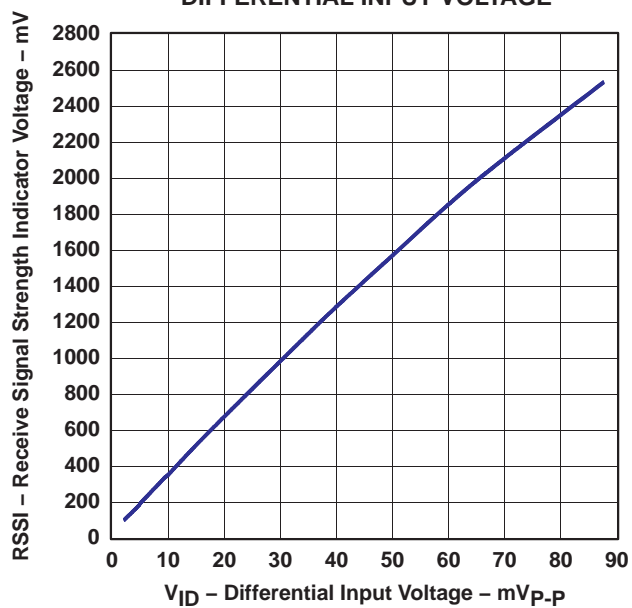

Figure 16

IMPORTANT NOTICE

Texas Instruments Incorporated (TI) reserves the right to make corrections, enhancements, improvements and other changes to its semiconductor products and services per JESD46, latest issue, and to discontinue any product or service per JESD48, latest issue. Buyers should obtain the latest relevant information before placing orders and should verify that such information is current and complete.

TI's published terms of sale for semiconductor products (<http://www.ti.com/sc/docs/stdterms.htm>) apply to the sale of packaged integrated circuit products that TI has qualified and released to market. Additional terms may apply to the use or sale of other types of TI products and services.

Reproduction of significant portions of TI information in TI data sheets is permissible only if reproduction is without alteration and is accompanied by all associated warranties, conditions, limitations, and notices. TI is not responsible or liable for such reproduced documentation. Information of third parties may be subject to additional restrictions. Resale of TI products or services with statements different from or beyond the parameters stated by TI for that product or service voids all express and any implied warranties for the associated TI product or service and is an unfair and deceptive business practice. TI is not responsible or liable for any such statements.

Buyers and others who are developing systems that incorporate TI products (collectively, "Designers") understand and agree that Designers remain responsible for using their independent analysis, evaluation and judgment in designing their applications and that Designers have full and exclusive responsibility to assure the safety of Designers' applications and compliance of their applications (and of all TI products used in or for Designers' applications) with all applicable regulations, laws and other applicable requirements. Designer represents that, with respect to their applications, Designer has all the necessary expertise to create and implement safeguards that (1) anticipate dangerous consequences of failures, (2) monitor failures and their consequences, and (3) lessen the likelihood of failures that might cause harm and take appropriate actions. Designer agrees that prior to using or distributing any applications that include TI products, Designer will thoroughly test such applications and the functionality of such TI products as used in such applications.

TI's provision of technical, application or other design advice, quality characterization, reliability data or other services or information, including, but not limited to, reference designs and materials relating to evaluation modules, (collectively, "TI Resources") are intended to assist designers who are developing applications that incorporate TI products; by downloading, accessing or using TI Resources in any way, Designer (individually or, if Designer is acting on behalf of a company, Designer's company) agrees to use any particular TI Resource solely for this purpose and subject to the terms of this Notice.

TI's provision of TI Resources does not expand or otherwise alter TI's applicable published warranties or warranty disclaimers for TI products, and no additional obligations or liabilities arise from TI providing such TI Resources. TI reserves the right to make corrections, enhancements, improvements and other changes to its TI Resources. TI has not conducted any testing other than that specifically described in the published documentation for a particular TI Resource.

Designer is authorized to use, copy and modify any individual TI Resource only in connection with the development of applications that include the TI product(s) identified in such TI Resource. NO OTHER LICENSE, EXPRESS OR IMPLIED, BY ESTOPPEL OR OTHERWISE TO ANY OTHER TI INTELLECTUAL PROPERTY RIGHT, AND NO LICENSE TO ANY TECHNOLOGY OR INTELLECTUAL PROPERTY RIGHT OF TI OR ANY THIRD PARTY IS GRANTED HEREIN, including but not limited to any patent right, copyright, mask work right, or other intellectual property right relating to any combination, machine, or process in which TI products or services are used. Information regarding or referencing third-party products or services does not constitute a license to use such products or services, or a warranty or endorsement thereof. Use of TI Resources may require a license from a third party under the patents or other intellectual property of the third party, or a license from TI under the patents or other intellectual property of TI.

TI RESOURCES ARE PROVIDED "AS IS" AND WITH ALL FAULTS. TI DISCLAIMS ALL OTHER WARRANTIES OR REPRESENTATIONS, EXPRESS OR IMPLIED, REGARDING RESOURCES OR USE THEREOF, INCLUDING BUT NOT LIMITED TO ACCURACY OR COMPLETENESS, TITLE, ANY EPIDEMIC FAILURE WARRANTY AND ANY IMPLIED WARRANTIES OF MERCHANTABILITY, FITNESS FOR A PARTICULAR PURPOSE, AND NON-INFRINGEMENT OF ANY THIRD PARTY INTELLECTUAL PROPERTY RIGHTS. TI SHALL NOT BE LIABLE FOR AND SHALL NOT DEFEND OR INDEMNIFY DESIGNER AGAINST ANY CLAIM, INCLUDING BUT NOT LIMITED TO ANY INFRINGEMENT CLAIM THAT RELATES TO OR IS BASED ON ANY COMBINATION OF PRODUCTS EVEN IF DESCRIBED IN TI RESOURCES OR OTHERWISE. IN NO EVENT SHALL TI BE LIABLE FOR ANY ACTUAL, DIRECT, SPECIAL, COLLATERAL, INDIRECT, PUNITIVE, INCIDENTAL, CONSEQUENTIAL OR EXEMPLARY DAMAGES IN CONNECTION WITH OR ARISING OUT OF TI RESOURCES OR USE THEREOF, AND REGARDLESS OF WHETHER TI HAS BEEN ADVISED OF THE POSSIBILITY OF SUCH DAMAGES.

Unless TI has explicitly designated an individual product as meeting the requirements of a particular industry standard (e.g., ISO/TS 16949 and ISO 26262), TI is not responsible for any failure to meet such industry standard requirements.

Where TI specifically promotes products as facilitating functional safety or as compliant with industry functional safety standards, such products are intended to help enable customers to design and create their own applications that meet applicable functional safety standards and requirements. Using products in an application does not by itself establish any safety features in the application. Designers must ensure compliance with safety-related requirements and standards applicable to their applications. Designer may not use any TI products in life-critical medical equipment unless authorized officers of the parties have executed a special contract specifically governing such use. Life-critical medical equipment is medical equipment where failure of such equipment would cause serious bodily injury or death (e.g., life support, pacemakers, defibrillators, heart pumps, neurostimulators, and implantables). Such equipment includes, without limitation, all medical devices identified by the U.S. Food and Drug Administration as Class III devices and equivalent classifications outside the U.S.

TI may expressly designate certain products as completing a particular qualification (e.g., Q100, Military Grade, or Enhanced Product). Designers agree that it has the necessary expertise to select the product with the appropriate qualification designation for their applications and that proper product selection is at Designers' own risk. Designers are solely responsible for compliance with all legal and regulatory requirements in connection with such selection.

Designer will fully indemnify TI and its representatives against any damages, costs, losses, and/or liabilities arising out of Designer's non-compliance with the terms and provisions of this Notice.