AUDIO DSP WITH ANALOG INTERFACE

Check for Samples: [TAS3204](#)

1 Introduction

1.1 Features

- **Digital Audio Processor**
 - Fully Programmable With the Graphical, Drag-and-Drop PurePath Studio™ Software Development Environment
 - 135-MHz Operation
 - 48-Bit Data Path With 76-Bit Accumulator
 - Hardware Single-Cycle Multiplier (28 × 48)
 - Five Simultaneous Operations Per Clock Cycle
 - Usable 768 Words Data RAM (48 Bit), Usable 1k Coefficient RAM (28 Bit)
 - Usable 2.5K Program RAM
 - 122 ms at 48 kHz, 5.8k Words 24-Bit Delay Memory
 - Slave Mode F_s is 44.1 kHz and 48 kHz
 - Master Mode F_s is 48 kHz
- **Analog Audio Input/Output**
 - Two 3:1 Stereo Analog Input MUXes
 - Four Differential ADCs (102 dB DNR, Typical)
 - Four Differential DACs (105 dB DNR, Typical)
- **Digital Audio Input/Output**
 - Two Synchronous Serial Audio Inputs (Four Channels)
 - Two Synchronous Serial Audio Outputs (Four Channels)
 - Input and Output Data Formats: 16-, 20-, or 24-Bit Data Left, Right, and I²S
- **System Control Processor**
 - Embedded 8051 WARP Microprocessor
 - Programmable Using Standard 8051 C Compilers
 - Up to Four Programmable GPIO Pins
- **General Features**
 - Two I²C Ports for Slave or Master Download
 - Single 3.3-V Power Supply
 - Integrated Regulators

1.2 Applications

- **MP3 Player/Music Phone Docks**
- **Speaker Bars**
- **Mini/Micro-Component Systems**
- **Musical Instruments**
- **Speaker Equalization**
- **Studio Monitors**



Please be aware that an important notice concerning availability, standard warranty, and use in critical applications of Texas Instruments semiconductor products and disclaimers thereto appears at the end of this data sheet.

PurePath Studio is a trademark of Texas Instruments.

1.3 Description

The TAS3204 is a highly-integrated audio system-on-chip (SOC) consisting of a fully-programmable, 48-bit digital audio processor, a 3:1 stereo analog input MUX, four ADCs, four DACs, and other analog functionality. The TAS3204 is programmable with the graphical PurePath Studio™ suite of DSP code development software. PurePath Studio is a highly intuitive, drag-and-drop environment that minimizes software development effort while allowing the end user to utilize the power and flexibility of the TAS3204's digital audio processing core.

TAS3204 processing capability includes speaker equalization and crossover, volume/bass/treble control, signal mixing/MUXing/splitting, delay compensation, dynamic range compression, and many other basic audio functions. Audio functions such as matrix decoding, stereo widening, surround sound virtualization and psychoacoustic bass boost are also available with either third-party or TI royalty-free algorithms.

The TAS3204 contains a custom-designed, fully-programmable 135-MHz, 48-bit digital audio processor. A 76-bit accumulator ensures that the high precision necessary for quality digital audio is maintained during arithmetic operations.

Four differential 102 dB DNR ADCs and four differential 105 dB DNR DACs ensure that high quality audio is maintained through the whole signal chain as well as increasing robustness against noise sources such as TDMA interference.

The TAS3204 is composed of eight functional blocks:

1. Clocking System
2. Digital Audio Interface
3. Analog Audio Interface
4. Power supply
5. Clocks, digital PLL
6. I²C control interface
7. 8051 MCUcontroller
8. Audio DSP – digital audio processing

Expanded Functional Block Diagram

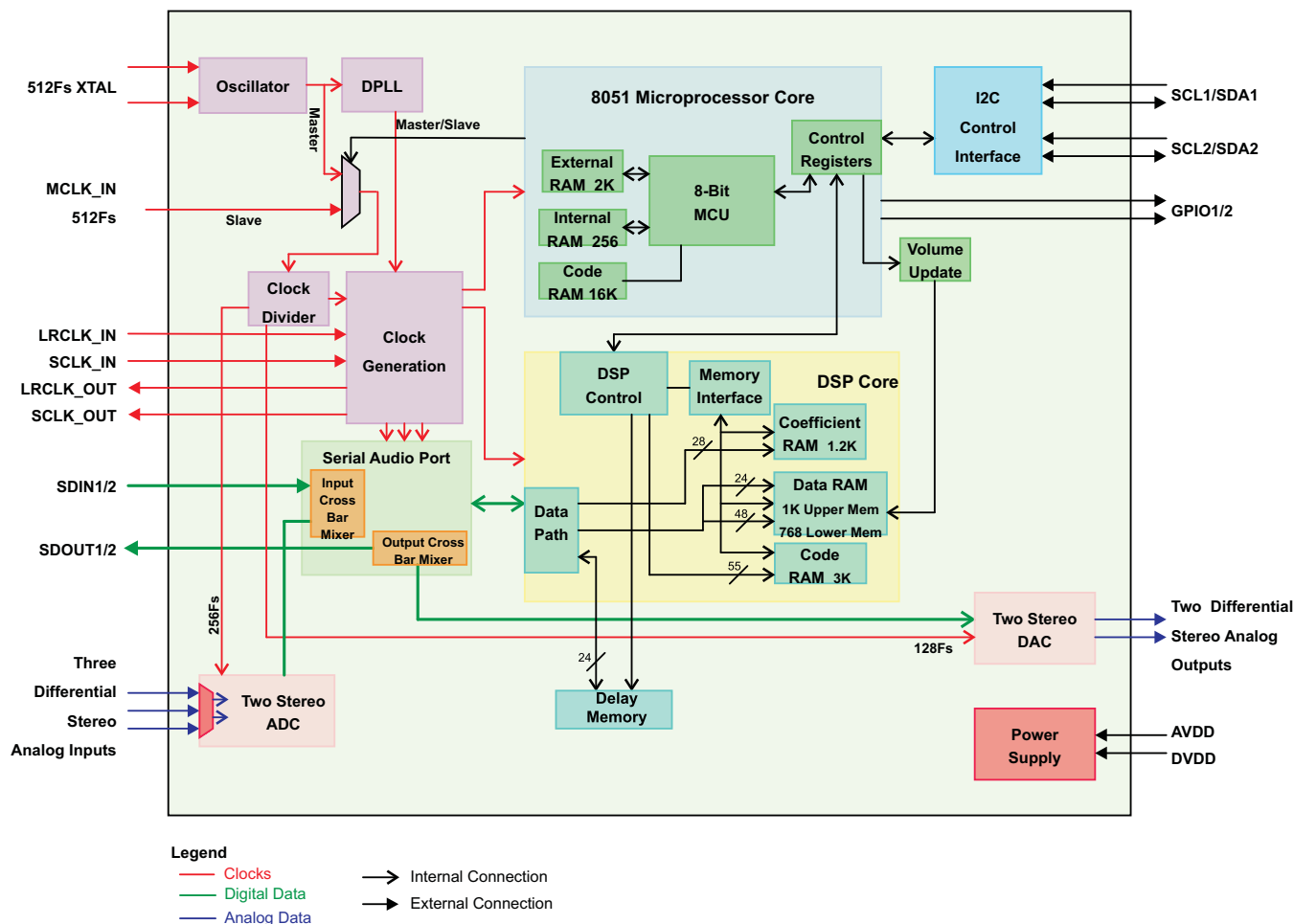

1.4 Ordering Information

T_A	PLASTIC 64-PIN PQFP (PN) ⁽¹⁾⁽²⁾
0°C to 70°C	TAS3204PAG

- (1) Package drawings, thermal data, and symbolization are available at www.ti.com/packaging.
- (2) For the most current package and ordering information, see the Package Option Addendum at the end of this document, or see the TI website at www.ti.com.

1	Introduction	1	11.1	Absolute Maximum Ratings	39
1.1	Features	1	11.2	Package Dissipation Ratings	39
1.2	Applications	1	11.3	Recommended Operating Conditions	39
1.3	Description	2	11.4	Electrical Characteristics	40
1.4	Ordering Information	3	11.5	Audio Specifications	40
2	Physical Characteristics	5	11.6	Timing Characteristics	43
2.1	Terminal Assignments	5	11.7	Master Clock	43
2.2	Terminal Descriptions	6	11.8	Serial Audio Port, Slave Mode	44
3	TAS3204 Clocking System	8	11.9	Serial Audio Port Master Mode Signals (TAS3204)	45
3.1	Core Clock Management	8	11.10	Pin-Related Characteristics of the SDA and SCL I/O Stages for F/S-Mode I ² C-Bus Devices	46
3.2	SAP Clock Management	9	11.11	Bus-Related Characteristics of the SDA and SCL I/O Stages for F/S-Mode I ² C-Bus Devices	46
4	Digital Audio Interface	11	11.12	Reset Timing	48
4.1	Serial Audio Port (SAP)	11	12	I²C Register Map	49
5	Analog Audio Interface	17	12.1	Clock Control Register (0x00)	50
5.1	Analog to Digital Converters ADCs	17	12.2	MCUcontroller Clock Control Register	50
5.2	Digital to Analog Converters DACs	17	12.3	Status Register (0x02)	51
5.3	Analog Reference System	17	12.4	I ² C Memory Load Control and Data Registers (0x04 and 0x05)	52
6	Embedded MCUcontroller	18	12.5	Memory Access Registers (0x06 and 0x07)	53
6.1	MCU Addressing Modes	18	12.6	Device Version (0x08)	54
6.2	Boot Up Sequence	19	12.7	Analog Power Down Control (0x10 and 0x11)	54
7	Digital Audio Processor	20	12.8	Analog Input Control (0x12)	55
7.1	Audio Digital Signal Processor Core	22	12.9	Dynamic Element Matching (0x13)	55
7.2	DAP Instructions Set	22	12.10	Current Control Select (0x14, 0x15, 0x17, 0x18)	56
7.3	DAP Data Word Structure	23	12.11	DAC Control (0x1A, 0x1B, 0x1D)	60
8	I²C Control Interface	25	12.12	ADC and DAC Reset (0x1E)	62
8.1	General I ² C Operations	25	12.13	ADC Input Gain Control (0x1F)	62
8.2	I ² C Master Interface	26	12.14	MCLK_OUT Divider (0x21 and 0x22)	63
8.3	I ² C Slave Mode Operation	31	12.15	Digital Cross Bar (0x30 to 0x3F)	63
9	TAS3204 Control Pins	35	12.16	Extended Special Function Registers (ESFR) Map	65
9.1	Reset ($\overline{\text{RESET}}$) - Power-Up Sequence	35	13	Application Information	70
9.2	Voltage Regulator Enable ($\overline{\text{VREG_EN}}$)	35	13.1	Schematics	70
9.3	Power Down ($\overline{\text{PDN}}$)	35	13.2	Recommended Oscillator Circuit	71
9.4	I ² C Bus Control (CS0)	36			
9.5	Programmable I/O (GPIO)	36			
10	Algorithm and Software Development Tools for TAS3204	38			
11	Electrical Specifications	39			

2 Physical Characteristics

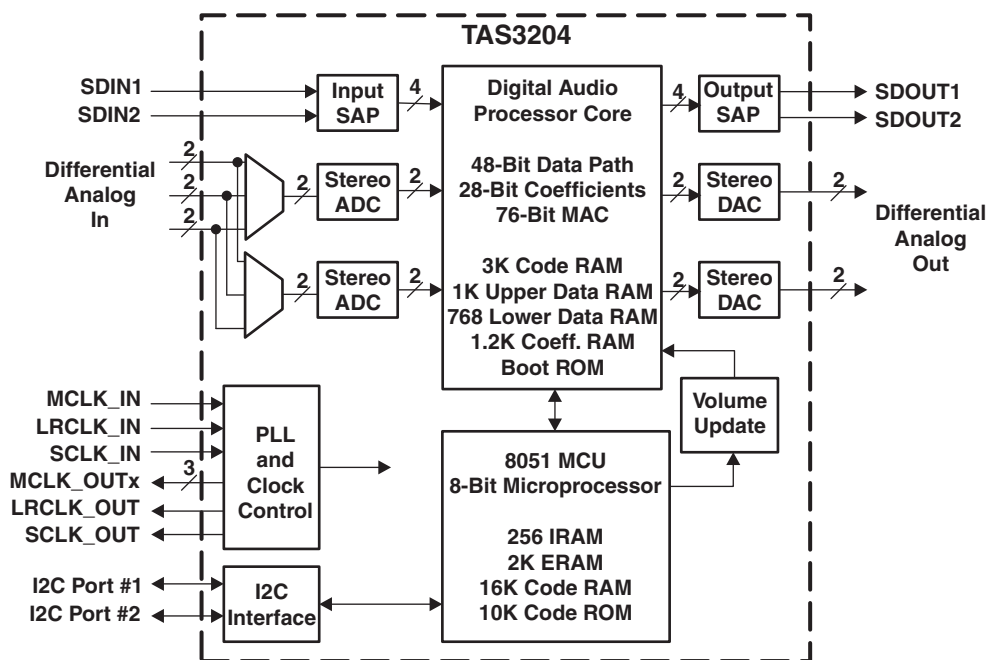

2.1 Terminal Assignments

PAG PACKAGE
(TOP VIEW)

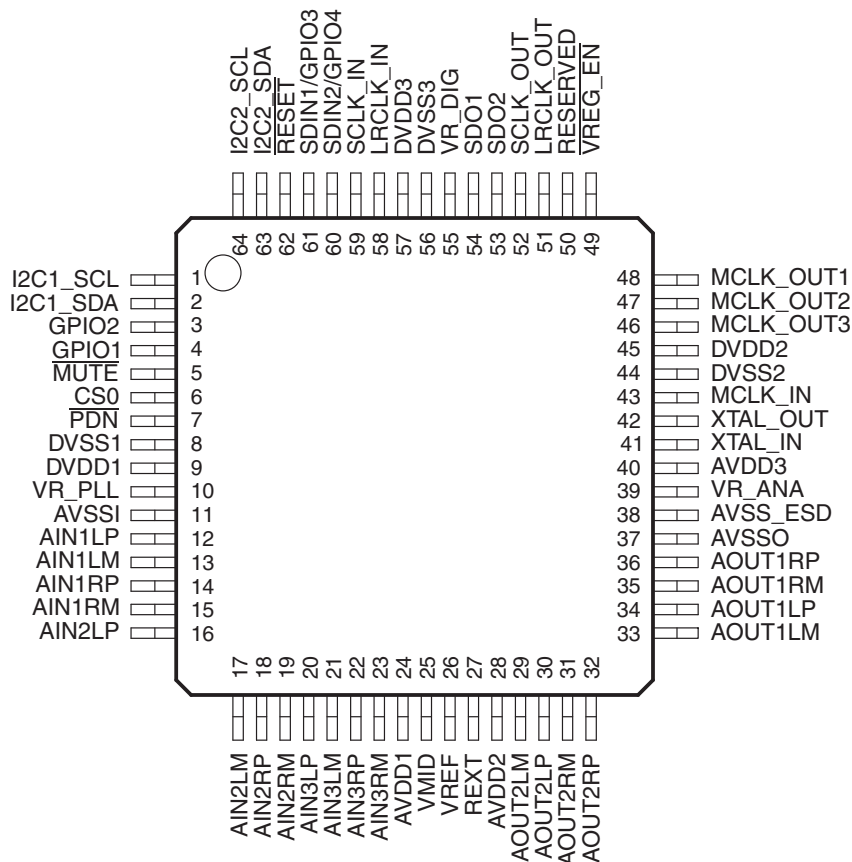

2.2 Terminal Descriptions

TERMINAL		INPUT/ OUTPUT ⁽¹⁾	PULLUP/ PULLDOWN ⁽²⁾	DESCRIPTION
NAME	NO.			
AIN1LM	13	Analog Input	Pull to VMID ⁽³⁾	Analog channel 1 left negative input
AIN1LP	12	Analog Input		Analog channel 1 left positive input
AIN1RM	15	Analog Input	Pull to VMID ⁽³⁾	Analog channel 1 right negative input
AIN1RP	14	Analog Input		Analog channel 1 right positive input
AIN2LM	17	Analog Input	Pull to VMID ⁽³⁾	Analog channel 2 left negative input
AIN2LP	16	Analog Input		Analog channel 2 left positive input
AIN2RM	19	Analog Input	Pull to VMID ⁽³⁾	Analog channel 2 right negative input
AIN2RP	18	Analog Input		Analog channel 2 right positive input
AIN3LM	21	Analog Input	Pull to VMID ⁽³⁾	Analog channel 3 left negative input
AIN3LP	20	Analog Input		Analog channel 3 left positive input
AIN3RM	23	Analog Input	Pull to VMID ⁽³⁾	Analog channel 3 right negative input
AIN3RP	22	Analog Input		Analog channel 3 right positive input
AOUT1LM	33	Analog Output		Analog channel 1 left negative output
AOUT1LP	34	Analog Output		Analog channel 1 left positive output
AOUT1RM	35	Analog Output		Analog channel 1 right negative output
AOUT1RP	36	Analog Output		Analog channel 1 right positive output
AOUT2LM	29	Analog Output		Analog channel 2 left negative output
AOUT2LP	30	Analog Output		Analog channel 2 left positive output
AOUT2RM	31	Analog Output		Analog channel 2 right negative output
AOUT2RP	32	Analog Output		Analog channel 2 right positive output
AVDBit 1	24	Power		3.3-V analog power. This pin must be decoupled according to good design practices.
AVSS1	11	Power		Analog ground
AVDBit 2	28	Power		3.3-V analog power. This pin must be decoupled according to good design practices.
AVSS2	37	Power		Analog ground
AVDBit 3	40	Power		3.3-V analog power supply. This pin must be decoupled according to good design practices.
AVSS3	38	Power		Analog ground
CS0	6	Digital Input		I ² C chip select
DVDBit 1	9	Power		3.3-V digital power. This pin must be decoupled according to good design practices.
DVSS1	8	Power		Digital ground
DVDBit 2	45	Power		3.3-V digital power. This pin must be decoupled according to good design practices.
DVSS2	44	Power		Digital ground
DVDBit 3	57	Power		3.3-V digital power. This pin must be decoupled according to good design practices.
DVSS3	56	Power		Digital ground
GPIO1	4	Digital IO		General purpose input/output pin #1.
GPIO2	3	Digital IO		General purpose input/output pin #2
I2C1_SCL	1	Digital Input		Slave I ² C serial control data interface input/output.
I2C1_SDA	2	Digital I/O		Slave I ² C serial clock input.
I2C2_SCL	64	Digital Input		Master I ² C serial control data interface input/output.

(1) I = input; O = output

(2) All pullups are 20- μ A *weak* pullups, and all pulldowns are 20- μ A *weak* pulldowns. The pullups and pulldowns are included to ensure proper input logic levels if the terminals are left unconnected (pullups \rightarrow logic 1 input; pulldowns \rightarrow logic 0 input). Devices that drive inputs with pullups must be able to sink 20 μ A while maintaining a logic-0 drive level. Devices that drive inputs with pulldowns must be able to source 20 μ A while maintaining a logic-1 drive level.

(3) Pull to VMID when analog input is in single-ended mode.

TERMINAL		INPUT/ OUTPUT ⁽¹⁾	PULLUP/ PULLDOWN ⁽²⁾	DESCRIPTION
NAME	NO.			
I2C2_SDA	63	Digital I/O		Master I ² C serial clock input.
LRCLK_IN	58	Digital Input	Pulldown	Left/right (frame) clock input for I ² S interface
LRCLK_OUT	51	Digital Output		Left/right (frame) clock output for I ² S interface
MCLK_IN	43	Digital Input	Pulldown	Master clock input for I ² S interface. Frequency = 512 x F _s
MCLK_OUT1	48	Digital Output		Master clock output for I ² S interface Frequency = 256 x F _s
MCLK_OUT2	47	Digital Output		Programmable master clock output divider
MCLK_OUT3	46	Digital Output		Programmable master clock output divider
MUTE	5	Digital Input	Pulldown	This pin needs to be programmed as mute pin in the application code. In has no function in default after reset.
$\overline{\text{PDN}}$	7	Digital Input		Powerdown active LOW. After successful boot, its function is defined by the boot code.
RESERVED	50	N/A	Pulldown	Pin must be connected to ground
$\overline{\text{RESET}}$	62	Digital Input	Pullup	Device reset. This pin is active low.
REXT	27	Analog Output		This pin must be connected to a 22 k Ω (1% tolerance) external resistor to ground to set analog currents. Trace capacitance must be kept low.
SCLK_IN	59	Digital Input		Serial (bit) clock input for I ² S interface
SCLK_OUT	52	Digital Output		Serial (bit) clock output for I ² S interface
SDIN1/GPIO3	61	Digital I/O	Pullup	Serial data input #1 for I ² S interface / general purpose input/output #3
SDIN2/GPIO4	60	Digital I/O	Pullup	Serial data input #2 for I ² S interface / general purpose input/output #4
SDOUT1	54	Digital Output		Serial data output #1 for I ² S interface
SDOUT2	53	Digital Output		Serial data output #2 for I ² S interface
VMID	25	Analog Output		Analog mid supply reference. This pin must be decoupled with a 0.1- μF low-ESR capacitor and an external 10- μF filter cap. ⁽⁴⁾
VR_ANA	39	Power		Voltage reference for analog supply. A pin-out of the internally regulated 1.8 V power. A 0.1- μF low ESR capacitor and a 4.7- μF filter capacitor must be connected between this terminal and AVSS. This terminal must not be used to power external devices. ⁽⁴⁾
VR_DIG	55	Power		Voltage reference for digital supply. A pin-out of the internally regulated 1.8 V power. A 0.1- μF low ESR capacitor and a 4.7- μF filter capacitor must be connected between this terminal and DVSS. This terminal must not be used to power external devices. ⁽⁴⁾
VR_PLL	10	Power		Voltage reference for DPLL supply. A pin-out of internally regulated 1.8-V power supply. A 0.1- μF low-ESR capacitor and a 4.7- μF filter capacitor must be connected between this terminal and DVSS. This terminal must not be used to power external devices. ⁽⁴⁾
VREF	26	Analog Output		Band gap output. A 0.1- μF low ESR capacitor should be connected between this terminal and AVSS. This terminal must not be used to power external devices. ⁽⁴⁾
$\overline{\text{VREG_EN}}$	49	Digital Input		Voltage regulator enable active low.
XTAL_IN	41	Digital Input		Crystal input. Frequency = 512 x F _s
XTAL_OUT	42	Digital Output		Crystal output. Frequency = 512 x F _s

(4) If desired, low ESR capacitance values can be implemented by paralleling two or more ceramic capacitors of equal value. Paralleling capacitors of equal value provide an extended high frequency supply decoupling.

3 TAS3204 Clocking System

Clock management for the TAS3204 consists of two control structures:

- Core Clock management
 - Oversees the selection of the clock frequencies for the 8051 MCU, the I²C controller, and the audio DSP core
 - The master clock (MCLK_IN or XTAL_IN) is the source for these clocks.
 - In most applications, the master clock drives an on-chip digital phase-locked loop (DPLL), and the DPLL output drives the MCU and audio DSP clocks.
 - DPLL bypass mode is also available, in which the high-speed master clock directly drives the MCU and audio DSP clocks.
- Serial Audio Port (SAP) clock management
 - Oversees SAP master/slave mode
 - Controls output of SCLKOUT, and LRCLK in the SAP master mode

Figure 3-1 shows a block diagram of the TAS3204 clocking scheme.

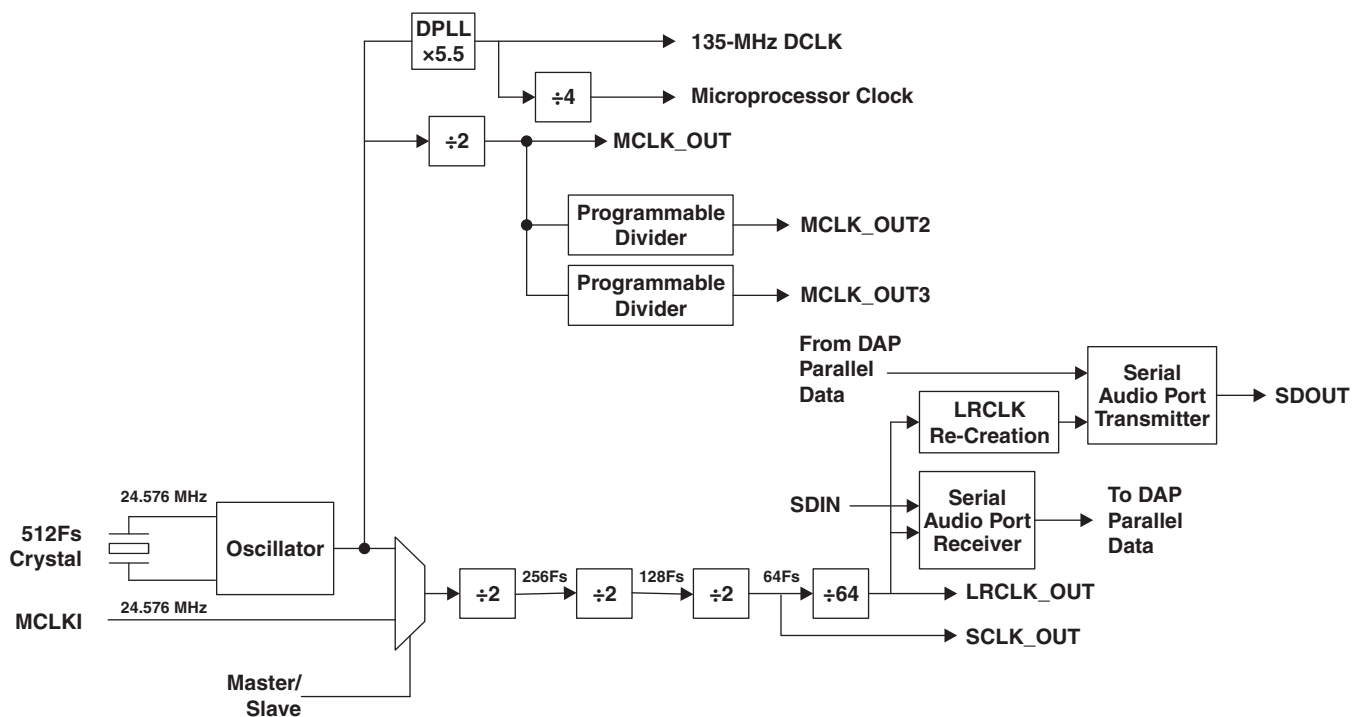

Figure 3-1. Clock Generation

3.1 Core Clock Management

The TAS3204 DSP, MCU, and I²C Controller core clocks are derived from the on chip oscillator provided that an external crystal and associated circuitry are provided. .

- DSP clock operates at a fixed frequency of $2816 \times F_s$
- MCU clock operates at a fixed frequency of $704 \times F_s$.
- I²C controller core operates at a fixed frequency of $(256 \times F_s)$.

3.2 SAP Clock Management

The Serial Audio Port in the TAS3204 can be clocked in two modes of operation: Master and Slave. By default, the TAS3204 is configured in master mode.

Clock Master operation: In Clock Master operation, the onboard oscillator provides the reference for the SAP clock outputs provided an external crystal is present.

- LRCLK_OUT fixed at a frequency of 48 kHz (F_s).
- SCLK_OUT is fixed at a frequency of $(64 \times F_s)$.
- MCLK_OUT is fixed at a frequency of $(256 \times F_s)$.
- In master mode, the external ASRC converts incoming serial audio data to 48-kHz sample rate synchronous to the internally generated serial audio data clocks.

Clock Slave operation: In Clock Slave operation, the SAP clock inputs are provided externally (that is, by a system controller) and passed through to the SAP Outputs. The MCLK_IN signal is internally divided down and sent directly to the ADC and DAC blocks, therefore analog audio performance is dependant on the quality of the MCLK_IN signal. As a result, degradation in analog performance is to be expected if the quality of MCLK_IN (that is, jitter, phase noise, etc) is not robust.

DISCLAIMER: Analog performance is not ensured in slave mode, as the analog performance depends upon the quality of the MCLK_IN. The TAS3204 is not robust with respect to MCLK_IN errors (glitches, etc.); if the MCLK_IN frequency changes under operation, the device must be reset.

- MCLK_IN ($512 \times F_s$),
- SCLK_IN ($64 \times F_s$), and
- LRCLK_IN (F_s) are supplied externally by an clocking device.
-

When the TAS3204 is used in a system in which the master clock frequency (f_{MCLK}) can change, the TAS3204 must be reset during the frequency change. In these cases, the procedure shown in [Figure 3-2](#) should be used.

In slave mode, all incoming serial audio data must be synchronous to an incoming LRCLK_IN of 44.1 kHz or 48 kHz.

The TAS3204 only supports dynamic sample-rate changes between any of the supported sample frequencies when a fixed-frequency master clock is provided. During dynamic sample-rate changes, the TAS3204 remains in normal operation and the register contents are preserved. To avoid producing audio artifacts during the sample-rate changes, a volume or mute control can be included in the application firmware that mutes the output signal during the sample-rate change. The fixed-frequency clock can be provided by a crystal attached to XTAL_IN and XTAL_OUT or an external 3.3-V fixed-frequency TTL source attached to MCLK_IN.

Changing the sample rate on the fly in slave mode should be handled by a host system controller. The TAS3204 does not include any internal clock error or click/pop detection management. Customer specific DAP filter coefficients must be uploaded by a host system controller when changing the sample rate.

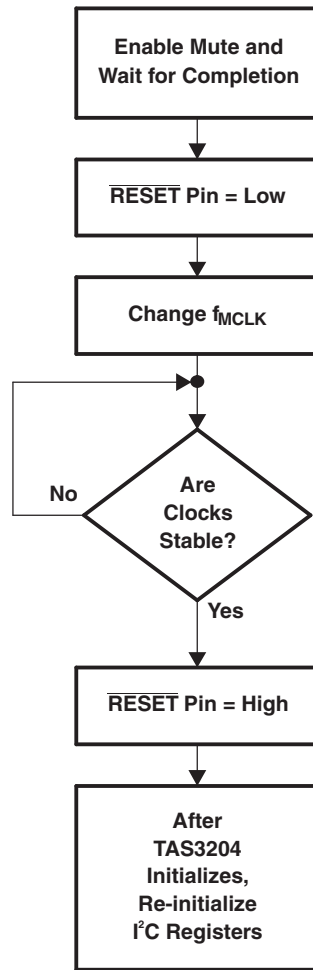

Figure 3-2. Master Clock Frequency (f_{MCLK}) Change Procedure

Table 3-1. TAS3204 MCLK and LRCLK Common Values (MCLK = 24.576 MHz or MCLK = 22.579 MHz)

F_S Sample Rate (kHz)	Ch Per SDIN	MCLK/LRCLK Ratio ($\times f_S$)	MCLK Freq (MHz)	SCLKIN Rate ($\times f_S$)	SCLK_IN Freq (MHz)	SCLK_OUT Rate ($\times f_S$)	Ch Per SDOUT	LRCLK (F_S)	PLL Multiplier	F_{DSPCLK} (MHz)	f_{DSPCLK}/f_S
Slave Mode, 2 Channels In, 2 Channels Out											
44.1	2	512	22.579	64	2.822	64	2	64	5.5	124.2	2816
48	2	256	24.576	64	3.072	64	2	64	5.5	135.2	2816
Master Mode, 2 Channels In, 2 Channels Out											
48	2	256	24.576	N/A	N/A	64	2	64	5.5	135.2	2816

4 Digital Audio Interface

4.1 Serial Audio Port (SAP)

The TAS3204 can accept four channels of 16, 20, or 24 bit digital serial audio in the I²S, discrete left justified, or discrete right justified formats.

The TAS3204 can provide four channels of 16, 20, or 24 bit digital serial audio in I²S, discrete left justified, or discrete right justified format. Output data rate is the same data rate as the input. The SDO_{OUT} output uses the SCLK_OUT and LRCLK_OUT signals to provide synchronization.

The TAS3204 supported data formats are listed in [Table 4-1](#).

Table 4-1. Supported Data Formats

Input SAP (SDIN1, SDIN2)	Output SAP (SDOUT1, SDOUT2)
2-channel I ² S	2-channel I ² S
2-channel left-justified	2-channel left-justified
2-channel right-justified	2-channel right-justified

Table 4-2. Serial Data Input and Output Formats

Mode	Input Control IM[3:0]	Output Control OM[3:0]	Serial Format	Word Lengths	Data Rates (kHz)	MAX SCLK (MHz)
2-channel	0000	0000	Left-justified	16, 20, 24	32–48	3.072
	0001	0001	Right-justified	16, 20, 24		
	0010	0010	I ² S	16, 20, 24		

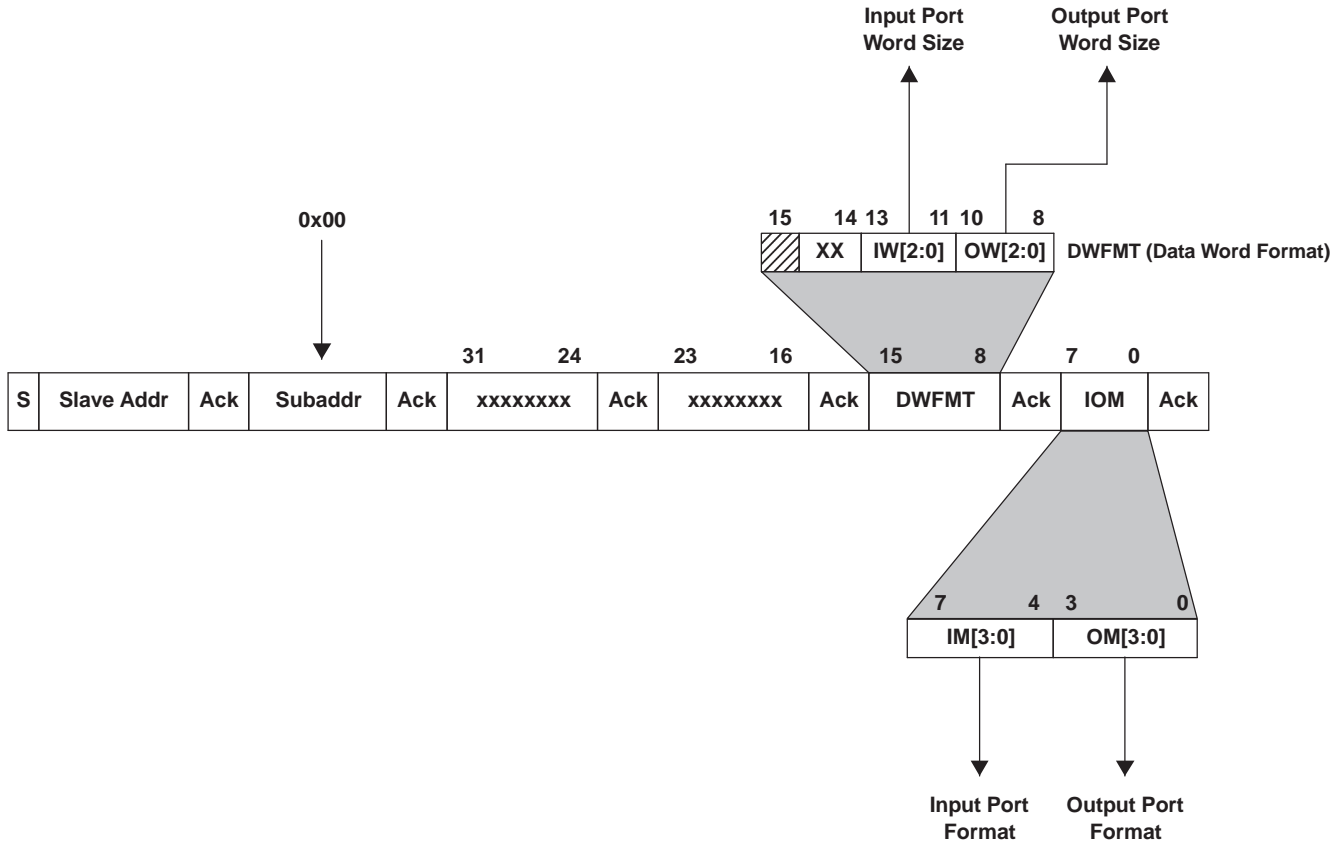

R0003-01

Figure 4-1. Serial Data Controls

Table 4-3. Serial Data Input and Output Data Word Sizes

IW1, OW1	IW0, OW0	FORMAT
0	0	Reserved
0	1	16-bit data
1	0	20-bit data
1	1	24-bit data

Following a reset, ensure that the clock register (0x00) is written before performing volume, treble, or bass updates.

Commands to reconfigure the SAP can be accompanied by mute and unmute commands for quiet operation. However, care must be taken to ensure that the mute command has completed before the SAP is commanded to reconfigure. Similarly, the TAS3204 should not be commanded to unmute until after the SAP has completed a reconfiguration. The reason for this is that an SAP configuration change while a volume or bass or treble update is taking place can cause the update not to be completed properly.

When the TAS3204 is transmitting serial data, it uses the negative edge of SCLK to output a new data bit. The TAS3204 samples incoming serial data on the rising edge of SCLK.

4.1.1 2-Channel I²S Timing

In 2-channel I²S timing, LRCLK is LOW when left-channel data is transmitted and HIGH when right-channel data is transmitted. SCLK is a bit clock running at $64 \times f_s$ which clocks in each bit of the data. There is a delay of one bit clock from the time the LRCLK signal changes state to the first bit of data on the data lines. The data is written MSB first and is valid on the rising edge of the bit clock. The TAS3204 masks unused trailing data-bit positions.

2-Channel I²S (Philips Format) Stereo Input/Output

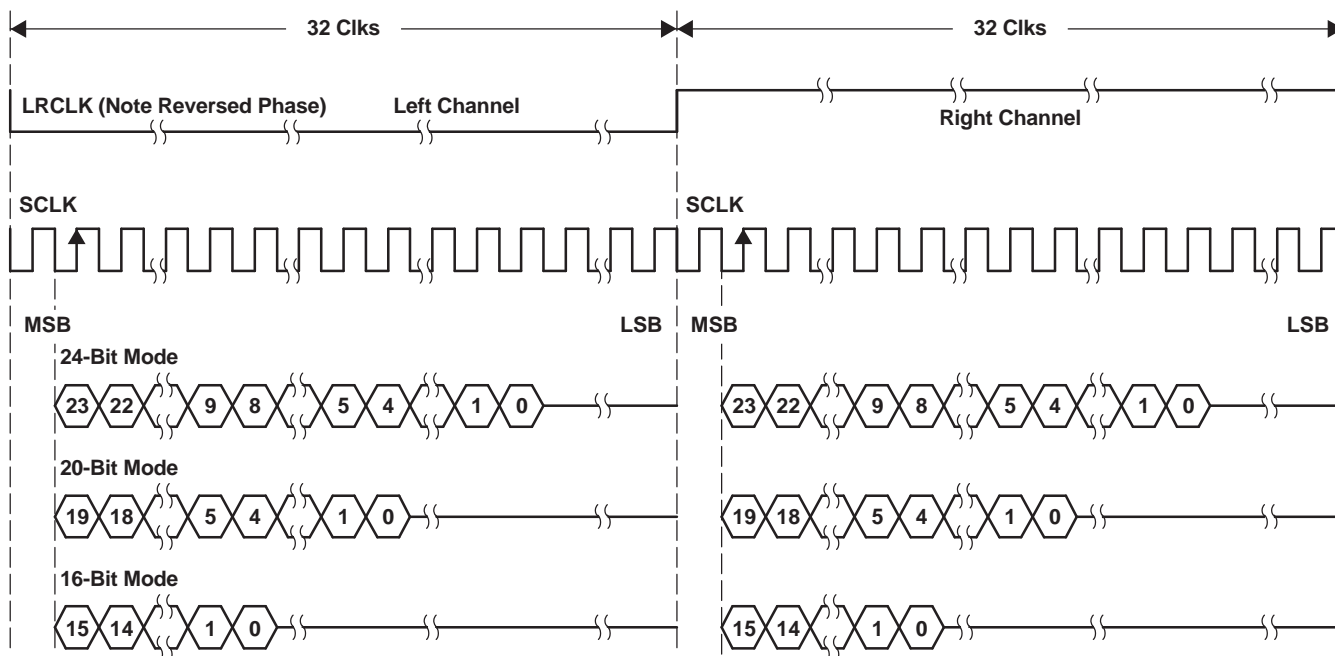

T0034-04

Figure 4-2. I²S 64f_s Format

4.1.2 2-Channel Left-Justified Timing

In 2-channel left-justified timing, LRCLK is HIGH when left-channel data is transmitted and LOW when right-channel data is transmitted. SCLK is a bit clock running at $64 \times f_s$, which clocks in each bit of the data. The first bit of data appears on the data lines at the same time LRCLK toggles. The data is written MSB first and is valid on the rising edge of the bit clock. The TAS3204 masks unused trailing data-bit positions.

2-Channel Left-Justified Stereo Input

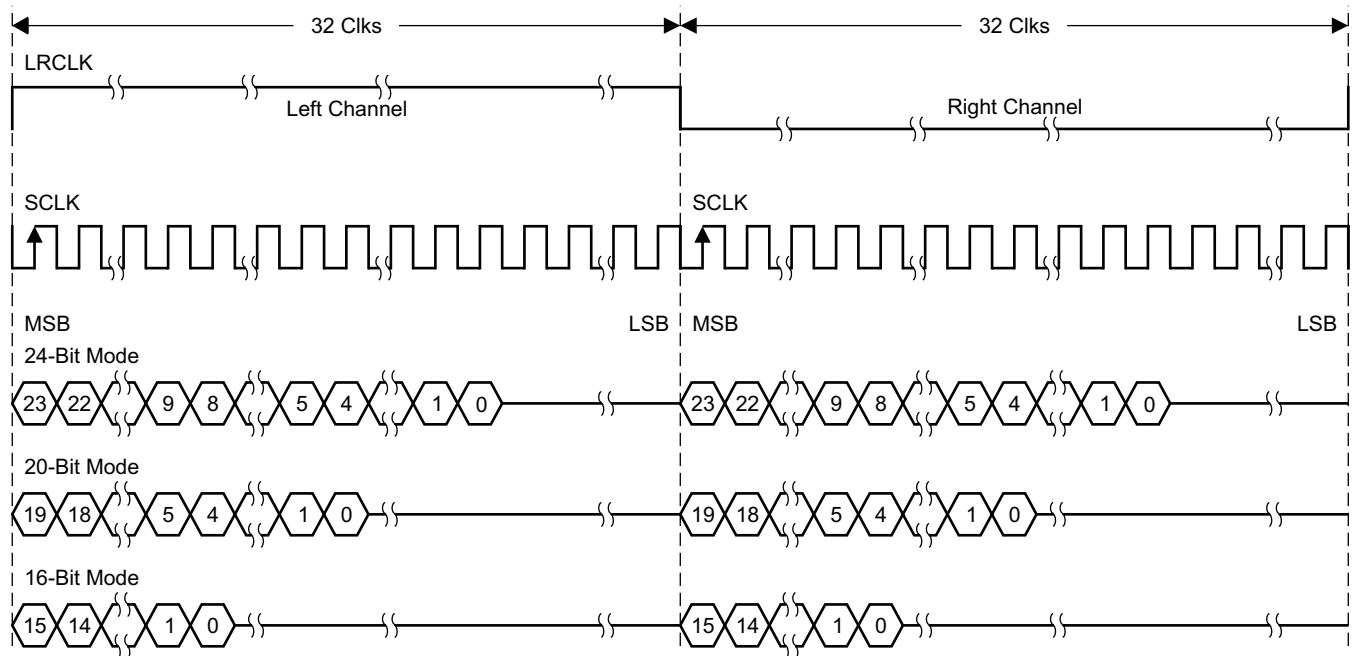

T0034-02

Figure 4-3. Left-Justified $64f_s$ Format

4.1.3 2-Channel Right-Justified Timing

In 2-channel right-justified (RJ) timing, LRCLK is HIGH when left-channel data is transmitted and LOW when right-channel data is transmitted. SCLK is a bit clock running at $64 \times f_s$ which clocks in each bit of the data. The first bit of data appears on the data lines 8 bit-clock periods (for 24-bit data) after LRCLK toggles. In the RJ mode, the last bit clock before LRCLK transitions always clocks the LSB of data. The data is written MSB first and is valid on the rising edge of the bit clock. The TAS3204 masks unused leading data-bit positions.

2-Channel Right-Justified (Sony Format) Stereo Input

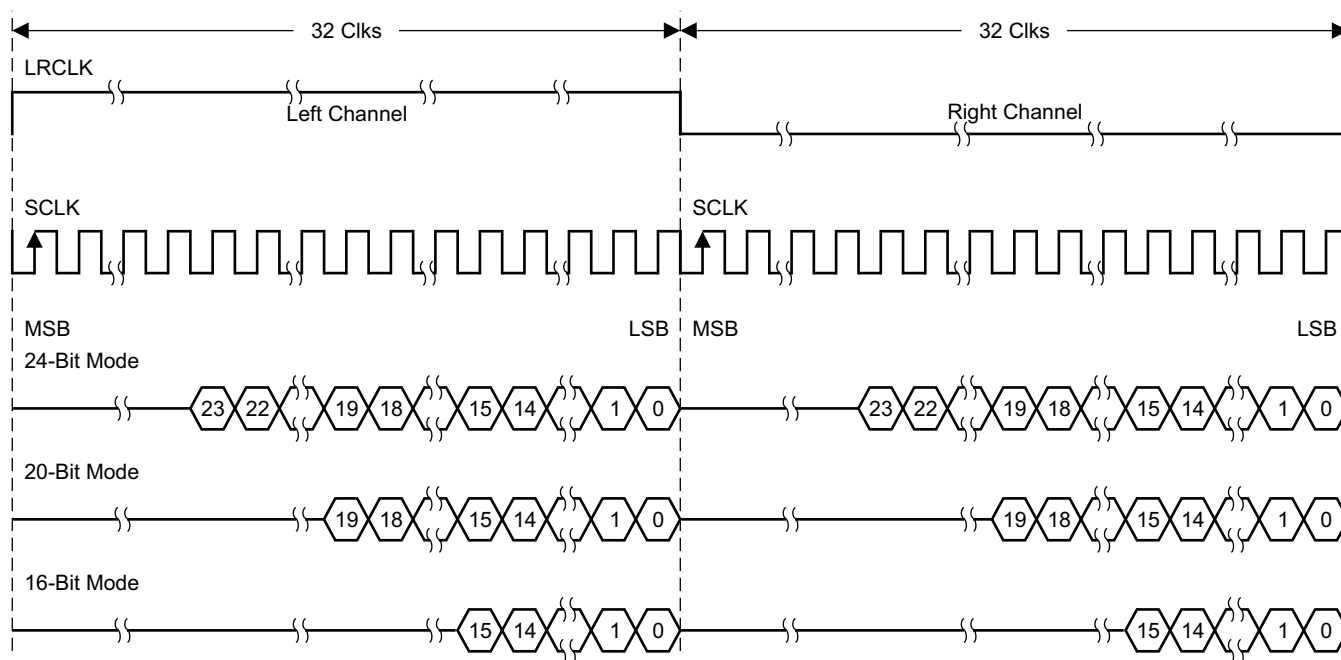

T0034-03

Figure 4-4. Right-Justified $64f_s$ Format

4.1.4 SAP Input to SAP Output—Processing Flow

All SAP data format options other than I²S result in a two-sample delay from input to output. If I²S formatting is used for both the input SAP and the output SAP, the polarity of LRCLK must be inverted. However, if I²S format conversions are performed between input and output, the delay becomes either 1.5 samples or 2.5 samples, depending on the processing clock frequency selected for the audio DSP core relative to the sample rate of the incoming data.

The I²S format uses the falling edge of LRCLK to begin a sample period, whereas all other formats use the rising edge of LRCLK to begin a sample period. This means that the input SAP and audio DSP core operate on sample windows that are 180° out of phase with respect to the sample window used by the output SAP. This phase difference results in the output SAP outputting a new data sample at the midpoint of the sample period used by the audio DSP core to process the data. If the processing cycle completes all processing tasks before the midpoint of the processing sample period, the output SAP outputs this processed data. However, if the processing time extends past the midpoint of the processing sample period, the output SAP outputs the data processed during the previous processing sample period. In the former case, the delay from input to output is 1.5 samples. In the latter case, the delay from input to output is 2.5 samples.

The delay from input to output can thus be either 1.5 or 2.5 sample times when data format conversions are performed that involve the I²S format. However, which delay time is obtained for a particular application is determinable and fixed for that application, providing care is taken in the selection of MCLK_IN/XTAL_IN with respect to the incoming sample clock, LRCLK.

5 Analog Audio Interface

5.1 Analog to Digital Converters ADCs

The TAS3204 has three differential analog stereo inputs that can be sent to either of two ADCs to be converted to digital data. The input multiplexers include a preamplifier. This amplifier is driving the ADCs, and it is digitally controlled with changes synchronized with the sample clock of the ADC. Minimal crosstalk between selected channels and unselected channels is maintained. When inputs are not needed they are configured for minimal noise. Also included in this module are two fully differential over sampled stereo ADCs. The ADCs are sigma-delta modulators with 256 times over-sampling ratio. Because of the over-sampling nature of the audio ADCs and integrated digital decimation filters, requirements for analog anti-aliasing filtering are relaxed. Filter performance for the ADCs are specified under physical characteristics.

5.2 Digital to Analog Converters DACs

The TAS3204 has two stereo audio DACs, each of which consists of a digital interpolation filter, digital sigma-delta modulator and an analog reconstruction filter. Each DAC can operate a maximum sampling frequency of 48 kHz. Each DAC upsamples the incoming data by 128 and performs interpolation filtering and processing on this data before conversion to a stereo analog output signal. The sigma-delta modulator always operates at a rate of 128x xFs, which ensures that quantization noise generated within the modulator stays low within the frequency band below Fs/2.4 at all sample rates. The digital interpolation filters for interpolation from Fs to 8xFs are included in the audio DSP upper memory (reserved for analog processing), while interpolation from 8xFs to 128 x Fs is done in a dedicated hardware sample and hold filter. The TAS3204 includes two stereo line driver outputs. All line drivers are capable of driving up to a 10-kΩ load. Each stereo output can be in power-down mode when not used. Popless operation is achieved by conforming to start and stop sequences in the device controller code.

5.3 Analog Reference System

This module provides all internal references needed by the analog modules. It also provides bias currents for all analog blocks. External decoupling capacitors are needed along with an external 1% tolerance resistor to set the internal bias currents. It includes a band-gap reference and several voltage buffers and a tracking current reference. The TAS3204 also uses an internally generated mid supply that is used to rereference all analog inputs and is present on all analog outputs. VMID is the analog mid supply and can be used when buffered externally to rereference the analog inputs and outputs. The voltage reference REXT requires a 22-kΩ 1% resistor to ground. The reference system can be powered down separately.

6 Embedded MCUcontroller

The 8051 MCUcontroller receives and distributes I²C data, and participates in most processing tasks requiring multiframe processing cycles. The MCU has its own data RAM for storing intermediate values and queuing I²C commands, a fixed boot-program ROM, and a program RAM. The MCU boot program cannot be altered. The MCU controller has specialized hardware for master and slave interface operation, volume updates, and a programmable interval timer interrupt. For more information see the *TAS3108/TAS3108IA Firmware Programmer's Guide* ([SLEU067](#)).

Once the MCUcontroller program memory has been loaded, it cannot be updated until the TAS3204 has been reset.

6.1 MCU Addressing Modes

The 256 bytes of internal data memory address space is accessible using indirect addressing instructions (including stack operations). However, only the lower 128 bytes are accessible using direct addressing. The upper 128 bytes of direct address Data Memory space are used to access Extended Special Function Registers (ESFRs).

6.1.1 Register Banks

There are four directly addressable register banks, only one of which may be selected at one time. The register banks occupy Internal Data Memory addresses from 00 hex to 1F hex.

6.1.2 Bit Addressing

The 16 bytes of Internal Data Memory that occupy addresses from 20 hex to 2F hex are bit addressable. SFRs that have addresses of the form 1XXXX000 binary are also bit addressable.

6.1.3 External Data Memory

External data memory occupies a 2K × 8 address space. This space contains the External Special Function Data Registers (ESFRs). The ESFR permit access and control of the hardware features and internal interfaces of the TAS3204.

6.1.4 Extended Special Function Registers

ESFRs provide signals needed for the M8051 to control the different blocks in the device. ESFR is an extension to the M8051. [Figure 6-1](#) shows how these registers are arranged.

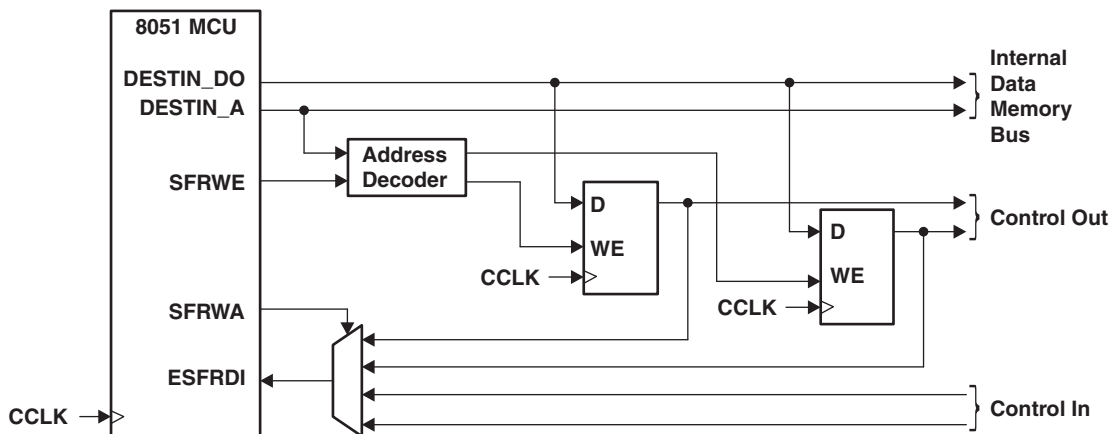

Figure 6-1. Extended Special Function Registers

6.1.5 Memory Mapped Registers for DAP Data Memory

The following memory mapped registers are used for communication with the digital audio processor.

Table 6-1. Memory Mapped Registers

Address	Register	Comment
0x0300	Dither Seed	Sets the dither seed value
0x0301	PC Start	Sets the starting address of the DAP
0x0302	Reserved	Reserved

Note that TAS3204 has the same memory mapped registers distinction of upper and lower memory for these registers.

6.2 Boot Up Sequence

On power up of the TAS3204 or immediately following a reset, the slave interface is disabled and the master interface is enabled. Using the master interface, the TAS3204 automatically tests to see if an I²C EEPROM is at address 1010x. The value x can be chip select, other information, or don't cares, depending on the EEPROM selected. If an EEPROM is present and it contains the correct header information and one or more blocks of program/memory data, the TAS3204 loads the program, coefficient, and/or data memories from the EEPROM. If a EEPROM is present, the download is complete when a header is read that has a zero-length data segment. At this point, the TAS3204 disables the master I²C interface, enables the slave I²C interface, and starts normal operation.

If no EEPROM is present or if an error occurred during the EEPROM read, TAS3204 disables the master I²C interface, enables the slave I²C interface, and loads the default configuration stored in the ROM. In this default configuration, the TAS3204 streams audio from input to output if the GPIO pin is LOW.

The master and slave interfaces do not operate simultaneously.

7 Digital Audio Processor

The DAP arithmetic unit is a fixed-point computational engine consisting of an arithmetic unit and data and coefficient memory blocks. The primary features of the DAP are:

- Two pipe parallel processing architecture
 - 48-bit data path with 76-bit accumulator
 - Hardware single cycle multiplier (28×48)
 - Three 48-bit general-purpose data registers and one 28-bit coefficient register
 - Four simultaneous operations per machine cycle
 - Shift right, shift left and bi-modal clip
 - Log2/Alog2
 - Magnitude Truncation
- Hardware acceleration units
 - Soft volume controller
 - Delay memory
 - Dither generator
 - log₂/2^x estimator
- 1024 + 768 dual port ports words of data (24 and 48 bits, respectively)
- 1228 words of coefficient memory (28 bits)
- 3K word of program RAM (55 bits)
- 5.88K words of 24-bits delay memory (1.22 ms)
- Coefficient RAM, data RAM, LFSR seed, program counter, and memory pointers are all mapped into the same memory space for convenient addressing by the MCUcontroller.
- Memory interface block contains four pointers, two for data memory and two for coefficient memory.

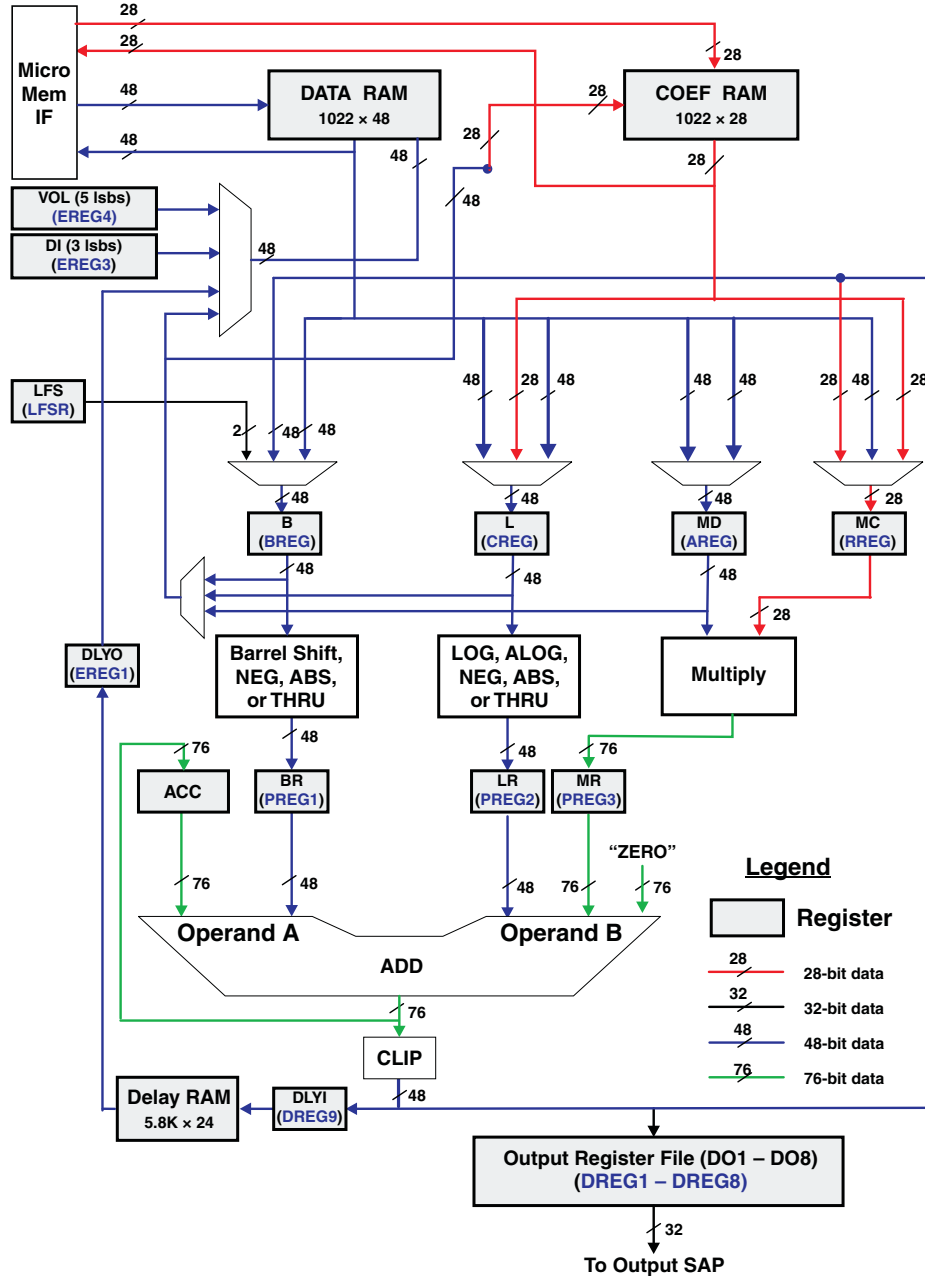

Figure 7-1. DSP Core Block Diagram

7.1 Audio Digital Signal Processor Core

The audio digital signal processor core arithmetic unit is a fixed-point computational engine consisting of an arithmetic unit and data and coefficient memory blocks. The audio processing structure, which can include mixers, multiplexers, volume, bass and treble, equalizers, dynamic range compression, or third-party algorithms, is running in the DAP. The 8051 MCUcontroller has access to DAP resources such as coefficient RAM and is able to support the DAP with certain tasks; for example, a volume ramp. The primary blocks of the audio DSP core are:

- 48-bit data path with 76-bit accumulator
- DSP controller
- Memory interface
- Coefficient RAM (1K×28)
- Data RAM – 24-bit upper memory (1K×24), 48-bit lower memory (768×48)
- Program RAM (3K×55)

The DAP is discussed in detail in the following sections.

7.2 DAP Instructions Set

Please see this information in the *TAS3xxx Audio DSP Instruction Set Reference Guide*

7.3 DAP Data Word Structure

Figure 7-2 shows the data word structure of the DAP arithmetic unit. Eight bits of overhead or guard bits are provided at the upper end of the 48-bit DAP word, and 16 bits of computational precision or noise bits are provided at the lower end of the 48-bit word. The incoming digital audio words are all positioned with the most significant bit abutting the 8-bit overhead/guard boundary. The sign bit in bit 39 indicates that all incoming audio samples are treated as signed data samples. The arithmetic engine is a 48-bit (25.23 format) processor consisting of a general-purpose 76-bit arithmetic logic unit and function-specific arithmetic blocks. Multiply operations (excluding the function-specific arithmetic blocks) always involve 48-bit DAP words and 28-bit coefficients (usually I²C programmable coefficients). If a group of products is to be added together, the 76-bit product of each multiplication is applied to a 76-bit adder, where a DSP-like multiply-accumulate (MAC) operation takes place. Biquad filter computations use the MAC operation to maintain precision in the intermediate computational stages.

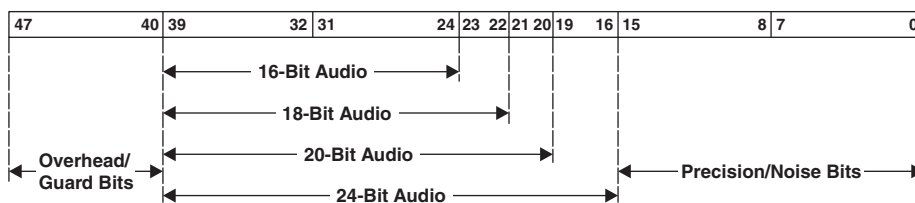

Figure 7-2. Arithmetic Unit Data Word Structure

To maximize the linear range of the 76-bit ALU, saturation logic is not used. In MAC computations, intermediate overflows are permitted, and it is assumed that subsequent terms in the computation flow correct the overflow condition (see Figure 7-3). The DAP memory banks include a dual port data RAM for storing intermediate results, a coefficient RAM, and a fixed program ROM. Only the coefficient RAM, assessable via the I²C bus, is available to the user.

		1	0	1	1	0	1	1	1	(-73)	-73
	+	1	1	0	0	1	1	0	1	(-51)	+ -51
		1	0	0	0	0	1	0	0	(-124)	-124
	+	1	1	0	1	0	0	1	1	(-45)	+ -45
Rollover		0	1	0	1	0	1	1	1	(57)	57
	+	0	0	1	1	1	0	1	1	(59)	+ 59
		1	0	0	1	0	0	1	0	(-110)	-110

Figure 7-3. DSP ALU Operation With Intermediate Overflow

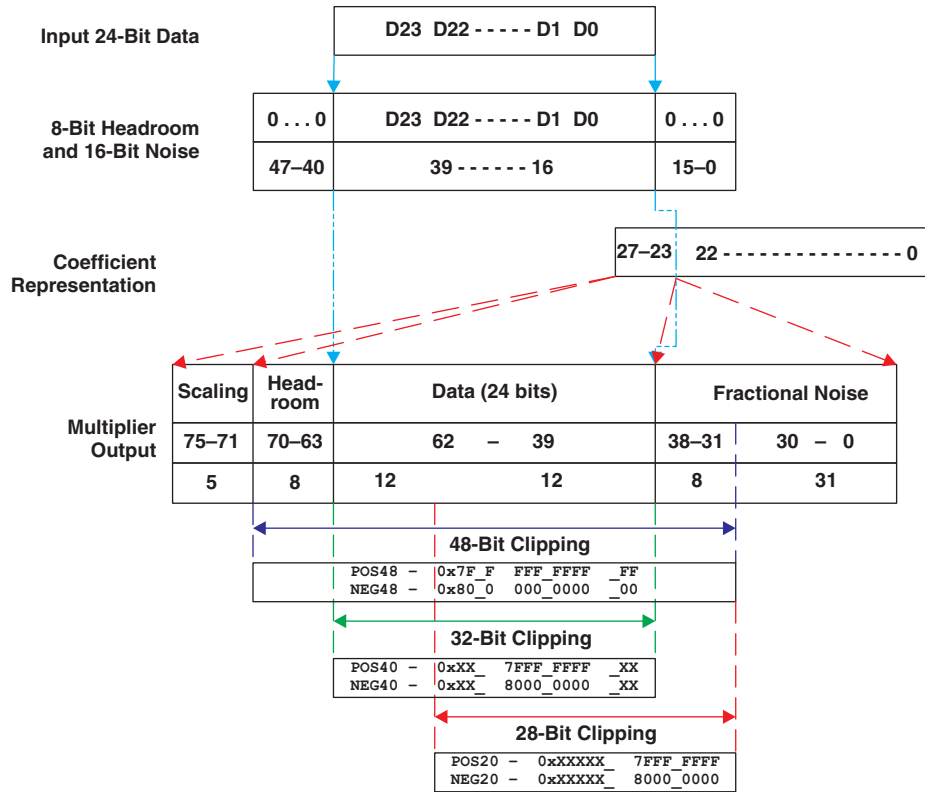

Figure 7-4. DAP Data-Path Data Representation

8 I²C Control Interface

The TAS3204 also two I²C interfaces that is compatible with the I²C bus protocol. The Master I²C supports 375-kbps data transfer rates for multiple 4-byte write and read operations (maximum is 20 bytes). The master I²C interface is used to load program and data from an external I²C EEPROM. The slave I²C interface supports both 100 kbps and 400 kbps data transfer rates for multiply 4 byte write and read operations (maximum 20 bytes). The slave I²C interface is used to program the registers of the device or to read the device status registers. Additionally, the slave I²C can be used to replace the information loaded by the I²C master interface.

8.1 General I²C Operations

The I²C bus employs two signals, SDA (serial data) and SCL (serial clock), to communicate between integrated circuits in a system. Data is transferred on the bus serially one bit at a time. The address and data are transferred in byte (8-bit) format with the most-significant bit (MSB) transferred first. In addition, each byte transferred on the bus is acknowledged by the receiving device with an acknowledge bit. Each transfer operation begins with the master device driving a start condition on the bus and ends with the master device driving a stop condition on the bus. The bus uses transitions on the data terminal (SDA) while the clock is HIGH to indicate a start and stop conditions. A HIGH-to-LOW transition on SDA indicates a start, and a LOW-to-HIGH transition indicates a stop. Normal data bit transitions must occur within the low time of the clock period. The master generates the 7-bit slave address and the read/write (R/W) bit to open communication with another device and then waits for an acknowledge condition. The slave holds SDA LOW during acknowledge clock period to indicate an acknowledgement. When this occurs, the master transmits the next byte of the sequence. Each device is addressed by a unique 7-bit slave address plus R/W bit (one byte). All compatible devices share the same signals via a bidirectional bus using a wired-AND connection. An external pullup resistor must be used for the SDA and SCL signals to set the HIGH level for the bus.

There is no limit on the number of bytes that can be transmitted between start and stop conditions. When the last word transfers, the master generates a stop condition to release the bus. [Figure 8-1](#) shows the TAS3204 read and write operation sequences.

As shown in [Figure 8-1](#), an I²C read transaction requires that the master device first issue a write transaction to give the TAS3204 the subaddress to be used in the read transaction that follows. This subaddress assignment write transaction is then followed by the read transaction. For write transactions, the subaddress is supplied in the first byte of data written, and this byte is followed by the data to be written. For I²C write transactions, the subaddress must always be included in the data written. There cannot be a separate write transaction to supply the subaddress, as was required for read transactions. If a subaddress-assignment-only write transaction is followed by a second write transaction supplying the data, erroneous behavior results. The first byte in the second write transaction is interpreted by the TAS3204 as another subaddress replacing the one previously written.

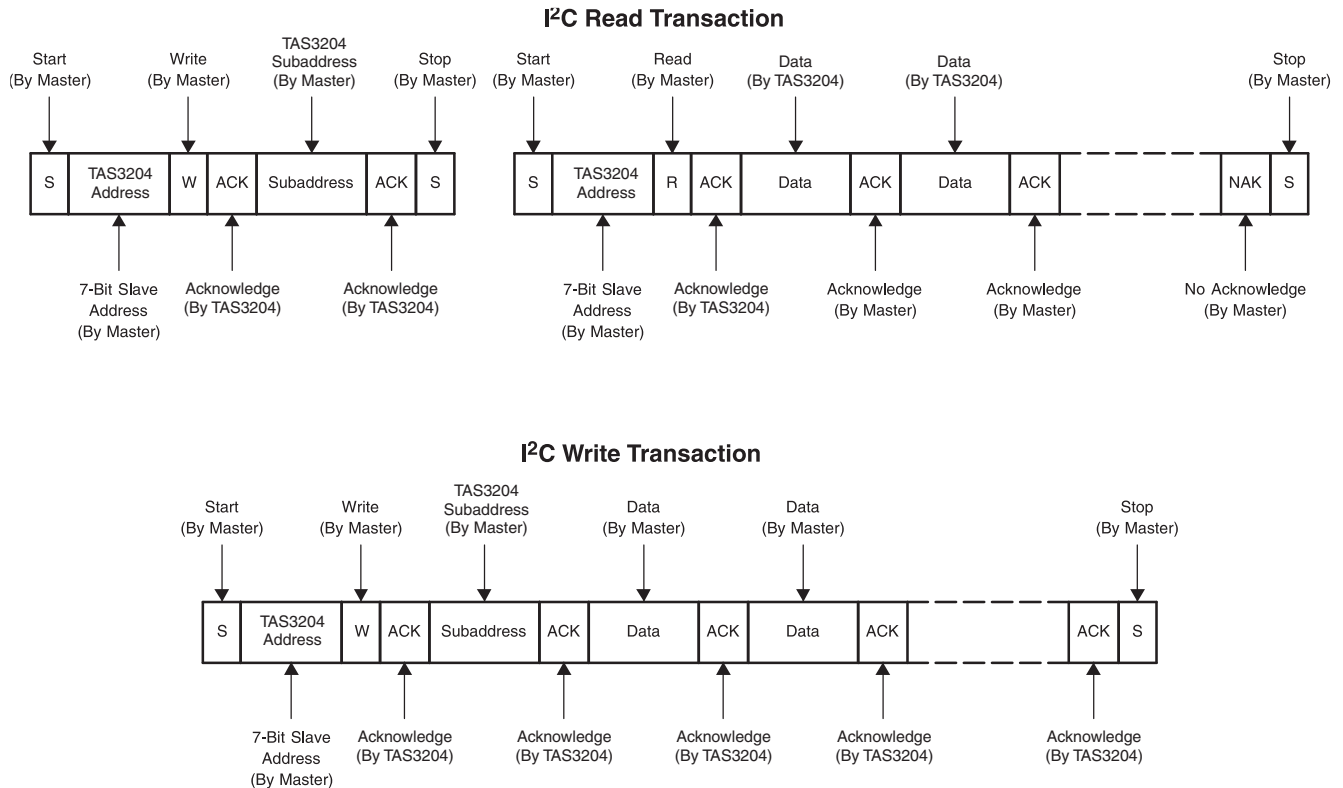

Figure 8-1. I²C Subaddress Access Protocol

8.2 I²C Master Interface

In the master mode, the I²C bus is used to:

- Load the program and coefficient data
 - MCU program memory
 - MCU extended memory
 - Audio DSP core program memory
 - Audio DSP core coefficient memory
 - Audio DSP core data memory

The TAS3204, when operating as an I²C master, can execute a complete download of any internal memory or any section of any internal memory without requiring any wait states.

When the TAS3204 operates as an I²C master, the TAS3204 generates a repeated start without an intervening stop command while downloading program and memory data from EEPROM. When a repeated start is sent to the EEPROM in read mode, the EEPROM enters a sequential read mode to transfer large blocks of data quickly.

The first action of the TAS3204 as master is to transmit a start condition along with the device address of the I²C EEPROM with the read/write bit cleared (0) to indicate a write. The EEPROM acknowledges the address byte, and the TAS3204 sends a subaddress byte, which the EEPROM acknowledges. Most EEPROMs have at least 2-byte addresses and acknowledge as many as are appropriate. At this point, the EEPROM sends a last acknowledge and becomes a slave transmitter. The TAS3204 acknowledges each byte repeatedly to continue reading each data byte that is stored in memory.

The memory load information starts with reading the header and data information that starts at subaddress 0 of the EEPROM. This information must then be stored in sequential memory addresses with no intervening gaps. The data blocks are contiguous blocks of data that immediately follow the header locations.

The TAS3204 memory data can be stored and loaded in (almost) any order. Additionally, this addressing scheme permits portions of the TAS3204 internal memories to be loaded.

I²C EEPROM Memory Map

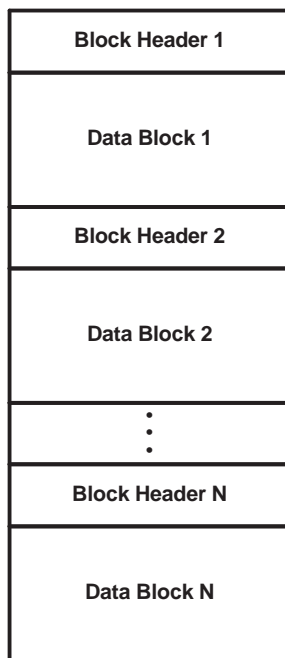

M0040–01

Figure 8-2. EEPROM Address Map

The TAS3204 sequentially reads EEPROM memory and loads its internal memory unless it does not find a valid memory header block, is not able to read the next memory location because the end of memory was reached, detects a checksum error, or reads an end-of-program header block. When it encounters an invalid header or read error, the TAS3204 attempts to read the header or memory location three times before it determines that it has an error. If the TAS3204 encounters a checksum error it attempts to reread the entire block of memory two more times before it determines that it has an error.

Once the MCU program memory has been loaded, it cannot be reloaded until the TAS3204 has been reset.

If an error is encountered, TAS3204 terminates its memory-load operation, loads the default configuration, and disables further master I²C bus operations.

If an end-of-program data block is read, the TAS3204 has completed the initial program load.

The I²C master mode uses the starting and ending I²C checksums to verify a proper EEPROM download. The first 16-bit data word received from the EEPROM, the I²C checksum at subaddress 0x00, is stored and compared against the 16-bit data word received for the last subaddress, the ending I²C checksum, and the checksum that is computed during the download. These three values must be equal. If the read and computed values do not match, the TAS3204 sets the memory read error bits in the status register and repeats the download from the EEPROM two more times. If the comparison check fails the third time, the TAS3204 sets the MCU program to the default value.

Table 8-1 shows the format of the EEPROM or other external memory load file. Each line of the file is a byte (in ASCII format). The checksum is the summation of all the bytes (with beginning and ending checksum fields = 00). The final checksum inserted into the checksum field is the lowest significant four bytes of the checksum.

Example:

Given the following example MCU data or program block (must be a multiple of 4 bytes for these blocks):

0x10 0x20 0x30 0x40 0x50 0x60 0x70 0x80

The checksum = 0x10 + 0x20 + 0x30 + 0x30 + 0x40 + 0x50 + 0x60 + 0x70 + 0x80 = 0x240, so

the values put in the checksum fields are MS byte = 0x02 and LS byte = 0x40.

If the checksum is >FFFFh, then the 2-byte checksum field is the least-significant 2 bytes.

For example, if the checksum is 0x1D 45B6, the checksum field is MS byte = 0x45 and LS byte = 0xB6.

Table 8-1. TAS3204 Master I²C Memory Block Structures

STARTING BYTE	DATA BLOCK FORMAT	SIZE	NOTES
12-Byte Header Block			
0	Checksum code Most Significant Byte	2 Bytes	Checksum of bytes 2 through N + 12. If this is a termination header, this value is 00 00
	Checksum code Least Significant Byte		
2	Header ID byte 1 = 0x00	2 Bytes	Must be 0x001F for the TAS3204 to load as part of initialization. Any other value terminates the initialization memory load sequence.
	Header ID byte 2 = 0x1F		
4	Memory to be loaded	1 Byte	0x00 – MCU program memory - or - termination header 0x01 – MCU external data memory 0x02 – Audio DSP core program memory 0x03 – Audio DSP core coefficient memory 0x04 – Audio DSP core data memory 0x05–06 – Audio DSP upper program memory 0x07 – Audio DSP Upper Coefficient Memory 0x08–FF – Reserved for future expansion
5	0x00	1 Byte	Reserved
6	Start TAS3204 memory address Most Significant Byte	2 Bytes	If this is a termination header, this value is 0000.
	Start TAS3204 memory address Least Significant Byte		
8	Total number of bytes transferred Most Significant Byte	2 Bytes	12 + data bytes + last checksum bytes. If this is a termination header, this value is 0000.
	Total number of bytes transferred Least Significant Byte		
10	0x00	1 Byte	Unused
11	0x00	1 Byte	Unused
Data Block for MCU Program or Data Memory (Following 12-Byte Header)			
12	Data Byte 1 (LSB)	4 Bytes	MCU Bytes 1-4
	Data Byte 2		
	Data Byte 3		
	Data byte 4 (MSB)		
16	Data byte 5	4 Bytes	MCU Bytes 5-8
	Data byte 6		
	Data byte 7		
	Data byte 8		
	⋮		
N + 8	Data byte 4x(Z – 1) + 1	4 Bytes	MCU Bytes N-N+4
	Data byte 4x(Z – 1) + 2		
	Data byte 4x(Z – 1) + 3		
	Data byte 4x(Z – 1) + 4 = N		

Table 8-1. TAS3204 Master I²C Memory Block Structures (continued)

STARTING BYTE	DATA BLOCK FORMAT	SIZE	NOTES
N + 12	0x00	4 Bytes	Repeated checksum bytes 2 through N + 11
	0x00		
	Checksum code MS Byte		
	Checksum code LS Byte		
Data Block for Audio DSP Core Coefficient Memory (Following 12-Byte Header)			
12	Data byte 1 (LS byte)	4 bytes	Coefficient word 1 (valid data in Bit 27–Bit 0) Bit 7–Bit 0
	Data byte 2		Bit 15–Bit 8
	Data byte 3		Bit 23–Bit 16
	Data byte 4 (MS byte)		Bit 31–Bit 24
16	Data byte 5	4 bytes	Coefficient word 2
	Data byte 6		
	Data byte 7		
	Data byte 8		
	⋮		
N + 8	Data byte $4 \times (Z - 1) + 1$	4 bytes	Coefficient word Z
	Data byte $4 \times (Z - 1) + 2$		
	Data byte $4 \times (Z - 1) + 3$		
	Data byte $4 \times (Z - 1) + 4 = N$		
N + 12	0x00	4 bytes	Repeated checksum bytes 2 through N + 11
	0x00		
	Checksum code MS byte		
	Checksum code LS byte		
Data Block for Audio DSP Core Data Memory (Following 12-Byte Header)			
12	Data byte 1 (LS byte)	6 bytes	Data word 1 Bit 7–Bit 0
	Data byte 2		Bit 15–Bit 8
	Data byte 3		Bit 23–Bit 16
	Data byte 4		Bit 31–Bit 24
	Data byte 5		Bit 39–Bit 32
	Data byte 6 (MS byte)		Bit 47–Bit 40
18	Data byte 7	6 bytes	Data 2
	Data byte 8		
	Data byte 9		
	Data byte 10		
	Data byte 11		
	Data byte 12		
	⋮		
N + 6	Data byte $6 \times (Z - 1) + 1$	6 bytes	Data Z
	Data byte $6 \times (Z - 1) + 2$		
	Data byte $6 \times (Z - 1) + 3$		
	Data byte $6 \times (Z - 1) + 4$		
	Data byte $6 \times (Z - 1) + 5$		
	Data byte $6 \times (Z - 1) + 6 = N$		

Table 8-1. TAS3204 Master I²C Memory Block Structures (continued)

STARTING BYTE	DATA BLOCK FORMAT	SIZE	NOTES
N + 12	0x00	6 bytes	Repeated checksum bytes 2 through N + 11
	0x00		
	0x00		
	0x00		
	Checksum code MS byte		
	Checksum code LS byte		
Data Block for Audio DSP Core Program Memory (Following 12-Byte Header)			
12	Program byte 1 (LS byte)	7 bytes	Program word 1 (valid data in Bit 53–Bit 0) Bit 7–Bit 0
	Program byte 2		Bit 15–D8
	Program byte 3		Bit 23–Bit 16
	Program byte 4		Bit 31–Bit 24
	Program byte 5		Bit 39–Bit 32
	Program byte 6		Bit 47–Bit 40
	Program byte 7 (MS byte)		Bit 55–Bit 48
19	Program byte 8	7 bytes	Program word 2
	Program byte 9		
	Program byte 10		
	Program byte 11		
	Program byte 12		
	Program byte 14		
	⋮		
N + 5	Program byte $7 \times (Z - 1) + 1$	7 bytes	Program word Z
	Program byte $7 \times (Z - 1) + 2$		
	Program byte $7 \times (Z - 1) + 3$		
	Program byte $7 \times (Z - 1) + 4$		
	Program byte $7 \times (Z - 1) + 5$		
	Program byte $7 \times (Z - 1) + 6$		
	Program byte $7 \times (Z - 1) + 7 = N$		
N + 12	0x00	7 bytes	Repeated checksum bytes 2 through N + 11
	0x00		
	0x00		
	0x00		
	0x00		
	Checksum code MS byte		
	Checksum code LS byte		
20-Byte Termination Block (Last Block of Entire Load Block)			
B _{LAST} – 19	0x00	2 bytes	First 2 bytes of termination block are always 0x0000.
	0x00		
B _{LAST} – 17	0x00	2 bytes	Second 2 bytes are always 0x001F.
	0x1F		
B _{LAST} – 15	0x00	1 byte	Last 16 bytes must each be 0x00.
B _{LAST} – 14	0x00	1 byte	
	⋮		
B _{LAST}	0x00	1 byte	

8.3 I²C Slave Mode Operation

In the slave mode, the I²C bus is used to:

- Load the program and coefficient data
 - MCU program memory
 - MCU extended memory
 - Audio DSP core program memory
 - Audio DSP core coefficient memory
 - Audio DSP core data memory
- Update coefficient and other control values
- Read status flags

The coefficient download operation in slave mode can be used to replace the I²C master-mode EEPROM download. The TAS3204 supports both random and sequential I²C transactions. The TAS3204 I²C slave address is 0b011010xy, where the first six bits are the TAS3204 device address and bit x is CS0, which is set by the TAS3204 internal MCU at power up. Bit y is the R/W bit. The pulldown resistance of CS0 creates a default 00 address when no connection is made to the pin. Table 6-1 and Table 8-3 show all the legal addresses for I²C slave and master modes.

Once the MCU program memory has been loaded, it cannot be updated until the TAS3204 has been reset.

The master and slave modes do not operate simultaneously.

When acting as an I²C slave, the data transfer rate is determined by the master device on the bus.

The I²C communication protocol for the I²C slave mode is shown in Figure 8-3.

The I²C communication protocol for the I²C slave mode is shown in Figure 8-3.

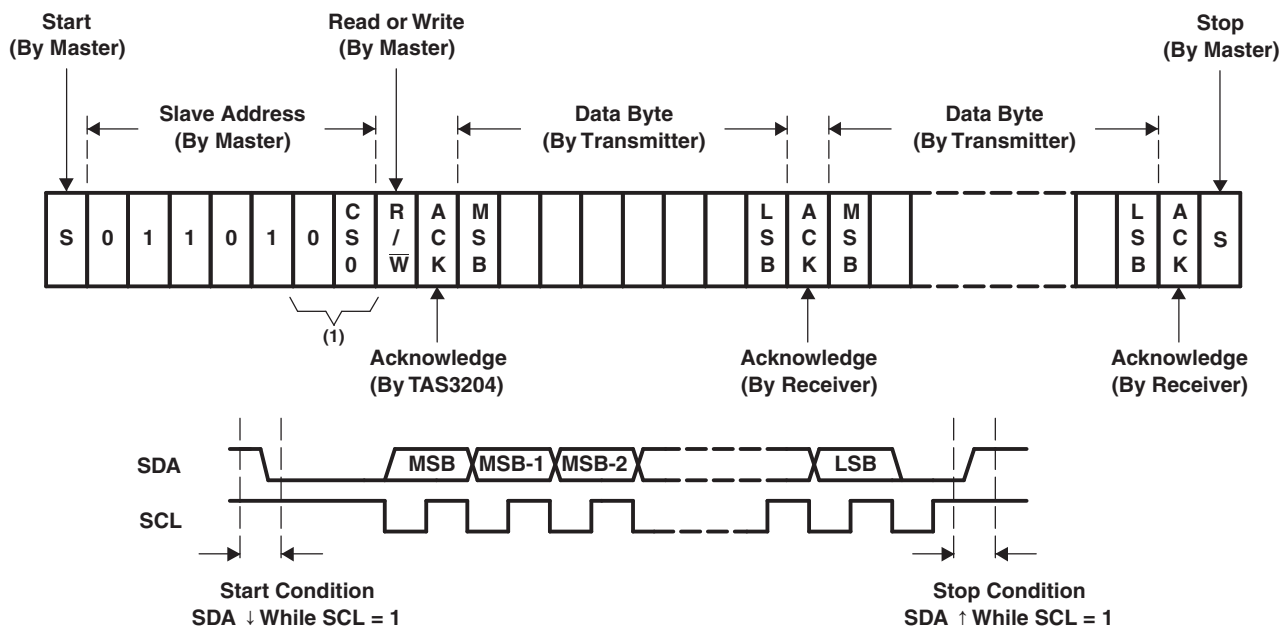

Figure 8-3. I²C Slave-Mode Communication Protocol

The number of data bytes plus the two bytes checksum must be evenly divisible by the word size.

The size field is equal to (header + payload + end checksum).

The checksum is contained in the last two data transfer bytes. These are bytes 7 and 8. On single word transfers (DAP data, DAP instruction), the checksum is always contained in a 8 byte frame that follows the last data word, last two bytes. For multiword data register transfers data (MCU Program RAM, MCU External Data RAM, and DAP Coefficient RAM), the checksum is included in the same byte transfer as data. To meet the requirement above, the number of words that are transferred contain modulo 8 + 6 in the case of MCU program and data memory, and modulo 2 + 1 in the case of coefficient memory. When the slave I²C download is used to replace or update sections of MCU program, MCU data, or DAP coefficient memory, it is necessary to take these transfer size restrictions into consideration when determining program, data, and coefficient placements.

The multi word transfers always store first word on the bus at a lower RAM address and increment such that the last word in the transfer is stored with the highest target RAM address. Consecutive I²C frame transfers increment target address such that the data in the last transfer is last in target memory address space.

When the first I²C slave download register is written by the system controller, the TAS3204 updates the status register by setting a error bit to indicate an error for the memory type that is being loaded. This error bit is reset when the operation complete and a valid checksum has been received. For example when the MCU program memory is being loaded, the TAS3204 sets a MCU program memory error indication in the status register at the start of the sequence. When the last byte of the MCU program memory and checksum is received, the TAS3204 clears the MCU program memory error indication. This enables the TAS3204 to preserve any error status indications that occur as a result of incomplete transfers of data/ checksum error during a series of data and program memory load operations.

The checksum is always contained in the last two bytes of the data block. The I²C slave download is terminated when a termination header with a zero-length byte-count file is received.

The status register always reflects status of EEPROM boot attempts, unless the user writes to the slave control register. A write to the slave boot control register causes the EEPROM status register to reflect slave boot attempt status.

NOTE

Once the MCU program memory has been loaded, further updates to this memory are prohibited until the device is reset. The TAS3204 I²C block does respond to the broadcast address (0x00).

Figure x.x shows the block format of the I²C slave Interface. or other external memory load file. Each line of the file is a byte (in ASCII format). The checksum is the summation of all the bytes (with beginning and ending checksum fields = 00). The final checksum inserted into the checksum field is the lowest significant four bytes of the checksum

Table 8-2. Slave Addresses

Base Address	CS0	R/W	Slave Address
0110 10	0	0	0x68
0110 10	0	1	0x69
0110 10	1	0	0x6A
0110 10	1	1	0x6B

Table 8-3. Master Addresses

Base Address	CS0	R/W	Master Address
1010 00	0	0	0xA0
1010 00	0	1	0xA1
1010 00	1	0	0xA2
1010 00	1	1	0xA3

The following is an example use of the I²C master address to access an external EEPROM. The TAS3204 can address up to two EEPROMs depending on the state of CS0. Initially, the TAS3204 comes up in I²C master mode. If it finds a memory such as the 24C512 EEPROM, it reads the headers and data as previously described. In this I²C master mode, the TAS3204 addresses the EEPROMs as shown in Table 8-4 and Table 8-5.

Table 8-4. EEPROM Address I²C TAS3204 Master Mode = 0xA1/A0

MSB					A0 (EEPROM)	CS0	R/W
1	0	1	0	0	0	0	1/0

Table 8-5. EEPROM Address I²C TAS3204 Master Mode = 0xA3/A2

MSB					A0 (EEPROM)	CS0	R/W
1	0	1	0	0	0	1	1/0

8.3.1 Multiple-Byte Write

Multiple data bytes are transmitted by the master device to slave as shown in Figure 8-4. After receiving each data byte, the TAS3204 responds with an acknowledge bit.

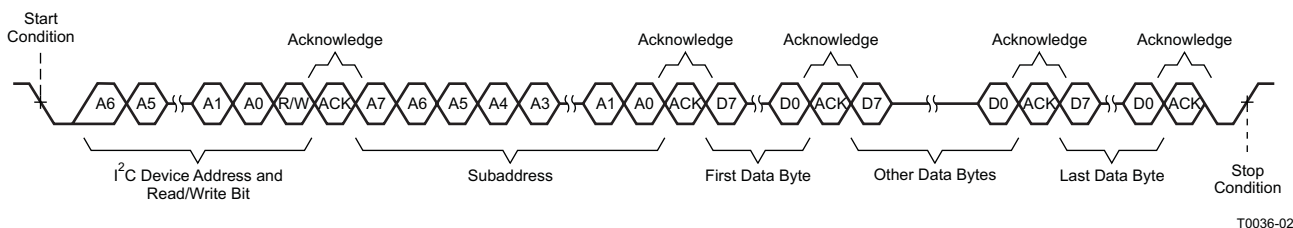

Figure 8-4. Multiple-Byte Write Transfer

8.3.2 Multiple-Byte Read

Multiple data bytes are transmitted by the TAS3204 to the master device as shown in Figure 8-5. Except for the last data byte, the master device responds with an acknowledge bit after receiving each data byte.

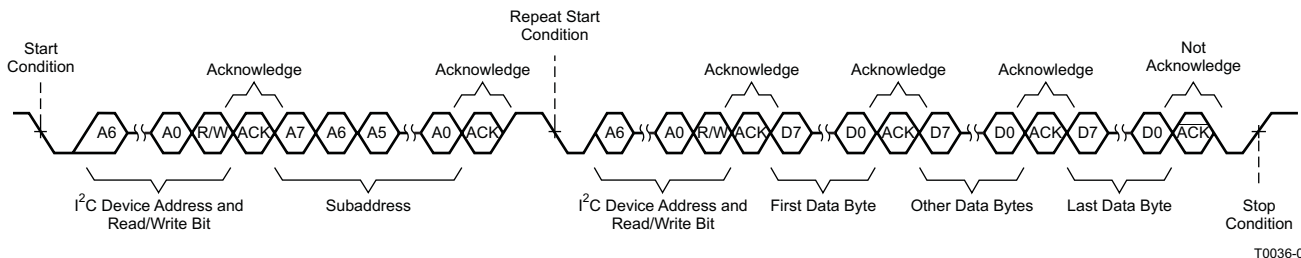

Figure 8-5. Multiple-Byte Read Transfer

Random I²C Transactions

Supplying a subaddress for each subaddress transaction is referred to as random I²C addressing. For random I²C read commands, the TAS3204 responds with data, a byte at a time, starting at the subaddress assigned, as long as the master device continues to respond with acknowledges. If a given subaddress does not use all 32 bits, the unused bits are read as logic 0. I²C write commands, however, are treated in accordance with the data assignment for that address space. If a write command is received for a mixer subaddress, for example, the TAS3204 expects to see five 32-bit words. If fewer than five data words have been received when a stop command (or another start command) is received, the data received is discarded.

Sequential I²C Transactions

The TAS3204 also supports sequential I²C addressing. For write transactions, if a subaddress is issued followed by data for that subaddress and the 15 subaddresses that follow, a sequential I²C write transaction has taken place, and the data for all 16 subaddresses is successfully received by the TAS3204. For I²C sequential write transactions, the subaddress then serves as the start address and the amount of data subsequently transmitted, before a stop or start is transmitted, determines how many subaddresses are written to. As was true for random addressing, sequential addressing requires that a complete set of data be transmitted. If only a partial set of data is written to the last subaddress, the data for the last subaddress is discarded. However, all other data written is accepted; just the incomplete data is discarded.

Sequential read transactions do not have restrictions on outputting only complete subaddress data sets.

If the master does not issue enough data-received acknowledges to receive all the data for a given subaddress, the master device simply does not receive all the data.

If the master device issues more data-received acknowledges than required to receive the data for a given subaddress, the master device simply receives complete or partial sets of data, depending on how many data-received acknowledges are issued from the subaddress(es) that follow. I²C read transactions, both sequential and random, can impose wait states.

9 TAS3204 Control Pins

9.1 Reset ($\overline{\text{RESET}}$) - Power-Up Sequence

The $\overline{\text{RESET}}$ pin is an asynchronous control signal that restores all TAS3204 components to the default configuration. When a reset occurs, the audio DSP core is put into an idle state and the 8051 starts initialization. A valid XTAL_IN must be present when clearing the $\overline{\text{RESET}}$ pin to initiate a device reset. A reset can be initiated by applying a logic 0 on $\overline{\text{RESET}}$.

As long as $\overline{\text{RESET}}$ is held LOW, the device is in the reset state. During reset, all I²C and serial data bus operations are ignored. The I²C interface SCL and SDA lines go into a high-impedance state and remain in that state until device initialization has completed.

The rising edge of the reset pulse begins the initialization housekeeping functions of clearing memory and setting the default register values. Once these are complete, the TAS3204 enables its master I²C interface and disables its slave I²C interface and starts the boot sequence.

Using the master interface, the TAS3204 automatically tests to see if an external I²C EEPROM is at address "1010x". The value x can be chip selects, other information, or don't care, depending on the EEPROM selected.

If a memory is present and it contains the correct header information and one or more blocks of program/memory data, the TAS3204 begins to load the program, coefficient and/or data memories from the external EEPROM. The download is considered complete when an end of program header is read by the TAS3204. At this point, the TAS3204 disables the master I²C interface, enable the slave I²C interface, and start normal operation. After a successful download, the MCU program counter is reset, and the downloaded MCU and DAP application firmware controls execution.

If no external EEPROM is present or if an error occurs during the EEPROM read, TAS3204 disables the master I²C interface and enables the slave I²C interface initialization to load the slave default configuration. In this default configuration, the TAS3204 streams audio from input to output if GPIO1 is asserted LOW; if the GPIO1 pin is asserted HIGH, the ADC and the DAC are muted.

On power up, it is recommended that the TAS3204 $\overline{\text{RESET}}$ be held LOW until DVDD has reached 3.3 V. This can be done by programming the system controller or by using an external RC delay circuit. The 1-k Ω and 1- μ F values provide a delay of approximately 200 μ s. The values of R and C can be adjusted to provide other delay values as necessary.

Note: The master and slave interfaces do not operate simultaneously.

9.2 Voltage Regulator Enable ($\overline{\text{VREG_EN}}$)

Setting the $\overline{\text{VREG_EN}}$ high shuts down all voltage regulators in the device. Internal register settings are lost in this power down mode. A full power-up/reset/program-load sequence must be completed before the device is operational.

9.3 Power Down ($\overline{\text{PDN}}$)

The TAS3204 supports a number of power-down modes.

$\overline{\text{PDN}}$ can be used to put the device into power saving standby mode. $\overline{\text{PDN}}$ is user-firmware definable. Its default configuration is to stop all clocks, power down all analog circuitry, and ramp down volume for all digital inputs. This mode is used to minimize power consumption while preserving register settings. If there is no EEPROM or if the EEPROM has an invalid image–i.e., an unsuccessful boot from the EEPROM–and $\overline{\text{PDN}}$ is pulled low, the TAS3204 is in powerdown mode. After a successful boot, $\overline{\text{PDN}}$ is defined by the boot code.

Individual power down DAC and ADC – Each stereo DAC and ADC can be powered down individually. To avoid audible artifacts at the outputs, the sequences defined in the TI document *TAS3108/TAS3108IA Firmware Programmer's Guide* ([SLEU067](#)) must be followed. The control signals for these operations are defined as ESFR. The feature is made available to the board controller via the I²C interface.

Power down of analog reference – The analog reference can be powered down if all DAC and ADC are powered down. This operation is handled by the device controller through the ESFRs, and is made available to the board controller via the I²C interface.

9.4 I²C Bus Control (CS0)

The TAS3204 has a control to specify the slave and master I²C address. This control permits up to two TAS3204 devices to be placed in a system without external logic. GPIO pins are level sensitive. They are not edge triggered.

See [Section 8.3](#) for a complete description of this pin.

9.5 Programmable I/O (GPIO)

The TAS3204 has four GPIO pins and two general purpose input pins that are 8051 firmware programmable.

GPIO1 and GPIO2 pins are single function I/O pins. Upon power up, GPIO1 is an input. If there is an unsuccessful boot and GPIO1 is pulled high externally, the DAC output is disabled. If there is an unsuccessful boot and the GPIO1 is pulled low externally, the DAC output is enabled. If there is a successful boot, GPIO1 is pulled low by the internal MCU, and its function is defined by the boot code in the EEPROM.

GPIO3 and GPIO4 pins are dual function I/O pins. These pins can be used as SDIN1 and SDIN2 respectively.

Mute and power down functions have to be programmed in the EEPROM boot code. These are general-purpose input pins and can be programmed for functions other than mute and power down.

9.5.1 No EEPROM is Present or a Memory Error Occurs

Following reset or power-up initialization with the EEPROM not present or if a memory error occurs, the TAS3204 is in one of two modes, depending on the setting of GPIO1.

• GPIO1 is logic HIGH

With GPIO1 held HIGH during initialization, the TAS3204 comes up in the default configuration with the serial data outputs not active. Once the TAS3204 has completed the default initialization procedure, after the status register is updated and the I²C slave interface is enabled, then GPIO1 is an output and is driven LOW. Following the HIGH-to-LOW transition of the GPIO pin, the system controller can access the TAS3204 through the I²C interface and read the status register to determine the load status.

If a memory-read error occurs, the TAS3204 reports the error in the status register (I²C subaddress 0x02).

• GPIO1 is logic LOW

With GPIO1 held LOW during initialization, the TAS3204 comes up in an I/O test configuration. In this case, once the TAS3204 completes its default test initialization procedure, the status register is updated, the I²C slave interface is enabled, and the TAS3204 streams audio unaltered from input to output as SDIN1 to SDOUT1, SDIN2 to SDOUT2, etc.

In this configuration, GPIO1 is an output signal that is driven LOW. If the external logic is no longer driving GPIO1 low after the load has completed (~100 ms following a reset if no EEPROM is present), the state of GPIO1 can be observed.

Then the system controller can access the TAS3204 through the I²C interface and read the status register to determine the load status.

If the GPIO1 state is not observed, the only indication that the device has completed its initialization procedure is the fact that the TAS3204 streams audio and the I²C slave interface has been enabled.

9.5.2 GPIO Pin Function After Device Is Programmed

Once the TAS3204 has been programmed, either through a successful boot load or via slave I²C download, the operation of GPIO can be programmed to be an input and/or output.

10 Algorithm and Software Development Tools for TAS3204

The TAS3204 algorithm and software development tool set is a combination of classical development tools and graphical development tools. The tool set is used to build, debug, and execute programs in both the audio DSP and 8051 sections of the TAS3204.

Classical development tooling includes text editors, compilers, assemblers, simulators, and source-level debuggers. The 8051 can be programmed exclusively in ANSI C.

The 8051 tool set is an off-the-shelf tool set, with modifications as specified in this document. The 8051 tool set is a complete environment with an IDE, editor, compiler, debugger, and simulator.

The audio DSP core is programmed exclusively in assembly. The audio DSP tool set is a complete environment with an IDE, context-sensitive editor, assembler, and simulator/debugger.

Graphical development tooling provides a means of programming the audio DSP core and 8051 through a graphical drag-and-drop interface using modular audio software components from a component library. The graphical tooling produces audio DSP assembly and 8051 ANSI C code as well as coefficients and data. The classical tools can also be used to produce the executable code.

In addition to building applications, the tool set supports the debug and execution of audio DSP and 8051 code on both simulators and EVM hardware.

11 Electrical Specifications

11.1 Absolute Maximum Ratings⁽¹⁾

over operating temperature range (unless otherwise noted)

DVDD	Digital supply voltage range		–0.5 V to 3.8 V
AVDD	Analog supply voltage range		–0.5 V to 3.8 V
V _I	Input voltage range	3.3-V TTL	–0.5 V to DVDD + 0.5 V
		1.8 V LVCMOS (XTLI)	–0.5 V to 2.3 V
V _O	Output voltage range	3.3 V TTL	–0.5 V to DVDD + 0.5 V
		1.8 V LVCMOS (XTLO)	–0.5 V to 2.3 V ⁽²⁾
I _{IK}	Input clamp current (V _I < 0 or V _I > DVDD)		±20 µA
I _{OK}	Output clamp current (V _O < 0 or V _O > DVDD)		±20 µA
T _A	Operating free-air temperature range		0°C to 70°C
T _{stg}	Storage temperature range		–65°C to 150°C

- (1) Stresses beyond those listed under *Absolute Maximum Ratings* may cause permanent damage to the device. These are stress ratings only, and functional operation of the device at these or any other conditions beyond those indicated under *Recommended Operating Conditions* is not implied. Exposure to absolute-maximum-rated conditions for extended periods may affect device reliability.
- (2) Pin XTAL_OUT is the only TAS3204 output that is derived from the internal 1.8-V logic supply. The absolute maximum rating listed is for reference; only a crystal should be connected to XTAL_OUT.

Note:

- VR_ANA is derived from TAS3204 internal 1.8-V voltage regulator. This terminal must not be used to power external devices.
- VR_DIG is derived from TAS3204 internal 1.8-V voltage regulator. This terminal must not be used to power external devices.
- VR_PLL is derived from TAS3204 internal 1.8-V voltage regulator. This terminal must not be used to power external devices.

11.2 Package Dissipation Ratings

Package Description			T _A ≤ 25°C Power Rating (mW)	Derating Factor Above T _A = 25°C (mW/°C)	T _A = 70°C Power Rating (mW)
Package Type	Pin Count	Package Designator			
TQFP	64	PAG	1869	23.36	818

11.3 Recommended Operating Conditions

		MIN	NOM	MAX	UNIT
DVDD	Digital supply voltage	3	3.3	3.6	V
AVDD	Analog supply voltage	3	3.3	3.6	V
V _{IH}	High-level input voltage	3.3 V TTL			V
		1.8 V LVCMOS (XTL_IN)	1.2		
V _{IL}	Low-level input voltage	3.3 V TTL		0.8	V
		1.8 V LVCMOS (XTL_IN)		0.5	
T _A	Operating ambient air temperature	0	25	70	°C
T _J	Operating junction temperature	0		105	°C
	Analog differential input		2		V _{RMS}
	Analog output load	Resistance		10	kΩ
		Capacitance		100	pF

11.4 Electrical Characteristics

over recommended operating conditions (unless otherwise noted)

PARAMETER		TEST CONDITIONS	MIN	TYP	MAX	UNIT	
V _{OH}	High-level output voltage	3.3-V TTL	I _{OH} = –4 mA			2.4	V
		1.8-V LVCMOS (XTL_OUT)	I _{OH} = –0.55 mA			1.44	
V _{OL}	Low-level output voltage	3.3-V TTL	I _{OL} = 4 mA			0.5	V
		1.8-V LVCMOS (XTL_OUT)	I _{OL} = 0.75 mA			0.4	
I _{OZ}	High-impedance output current	3.3-V TTL	V _I = V _{IL}			±20	μA
I _{IL}	Low-level input current	3.3-V TTL	V _I = V _{IL}			±20	μA
		1.8-V LVCMOS (XTL_IN)	V _I = V _{IL}			±20	
I _{IH}	High-level input current	3.3-V TTL	V _I = V _{IH}			±20	μA
		1.8-V LVCMOS (XTL_IN)	V _I = V _{IH}			±20	
I _{DVDD}	Digital supply current	Normal operation	MCLK_IN = 24.576 MHz, LRCLK = 48 kHz			130	mA
I _{AVDD}	Analog supply current	Normal operation	MCLK_IN = 24.576 MHz, LRCLK = 48 kHz			60	mA
Power Dissipation (Total)	Digital and analog supply current	Normal operation	MCLK_IN = 24.576 MHz, LRCLK = 48 kHz			627	mW
		Standby mode	With voltage regulators on			23	mW
			With voltage regulators off			825	μW
		Reset mode				20	mW
VR_ANA	Internal voltage regulator – analog		1.6	1.8	1.98	V	
VR_PLL	Internal voltage regulator – PLL		1.6	1.8	1.98	V	
VR_DIG	Internal voltage regulator – digital		1.6	1.8	1.98	V	

11.5 Audio Specifications

T_A = 25°C, AVDD = 3.3 V, DVDD = 3.3 V, Fs = 48 kHz, 1-kHz sine wave full scale, over operating free-air temperature range (unless otherwise noted)

PARAMETER		TEST CONDITIONS	MIN	TYP	MAX	UNIT
Overall performance: input ADC – DAP – DAC – line out	Dynamic range	Evaluation module. A-weighted, –60 dB with respect to full scale		100		dB
	THD+N	Evaluation module. –3 dB with respect to full scale		101		dB
ADC section	Dynamic range	A-weighted, –60 dB with respect to full scale.		102		dB
	THD+N	–4 dB with respect to full scale.		93		dB
	Crosstalk	One channel = –3 dB; Other channel = 0 V		84		dB
	Power supply rejection ratio	1 kHz, 100 mVpp on AVDD		57		dB
	Input resistance			20		kΩ
	Input capacitance			10		pF
ADC decimation filter	Pass band edge			0.45Fs		Hz
	Pass band ripple			±0.01		dB
	Stop band edge			0.55Fs		Hz
	Stop band attenuation			100		dB
	Group delay			37±Fs		Sec

Audio Specifications (continued)

T_A = 25°C, AVDD = 3.3 V, DVDD = 3.3 V, Fs = 48 kHz, 1-kHz sine wave full scale, over operating free-air temperature range (unless otherwise noted)

PARAMETER		TEST CONDITIONS	MIN	TYP	MAX	UNIT	
DAC section	Differential full scale output voltage			2		V _{RMS}	
	Dynamic range	A-weighted, –60 dB with respect to full scale		105		dB	
	THD+N	–1-dBFS input, 0-dB gain		95		dB	
	Crosstalk	DAC to ADC	One channel –3 dBFS; Other channel 0 V		84		dB
		ADC to DAC	One channel –3 dB; Other channel 0 V		84		dB
		DAC to DAC	One channel –3 dBFS; Other channel 0 V		84		dB
	Power supply rejection ratio	1 kHz, 100 mVpp on AVDD		56		dB	
DC offset	With respect to V _{REF}				mV		
DAC interpolation filter	Pass band edge			0.45Fs		Hz	
	Pass band ripple			±0.06		dB	
	Transition band			1.45 Fs to 0.55Fs		Hz	
	Stop band edge			7.4Fs		Hz	
	Stop band attenuation			–65		dB	
	Filter group delay			21÷Fs		Sec	

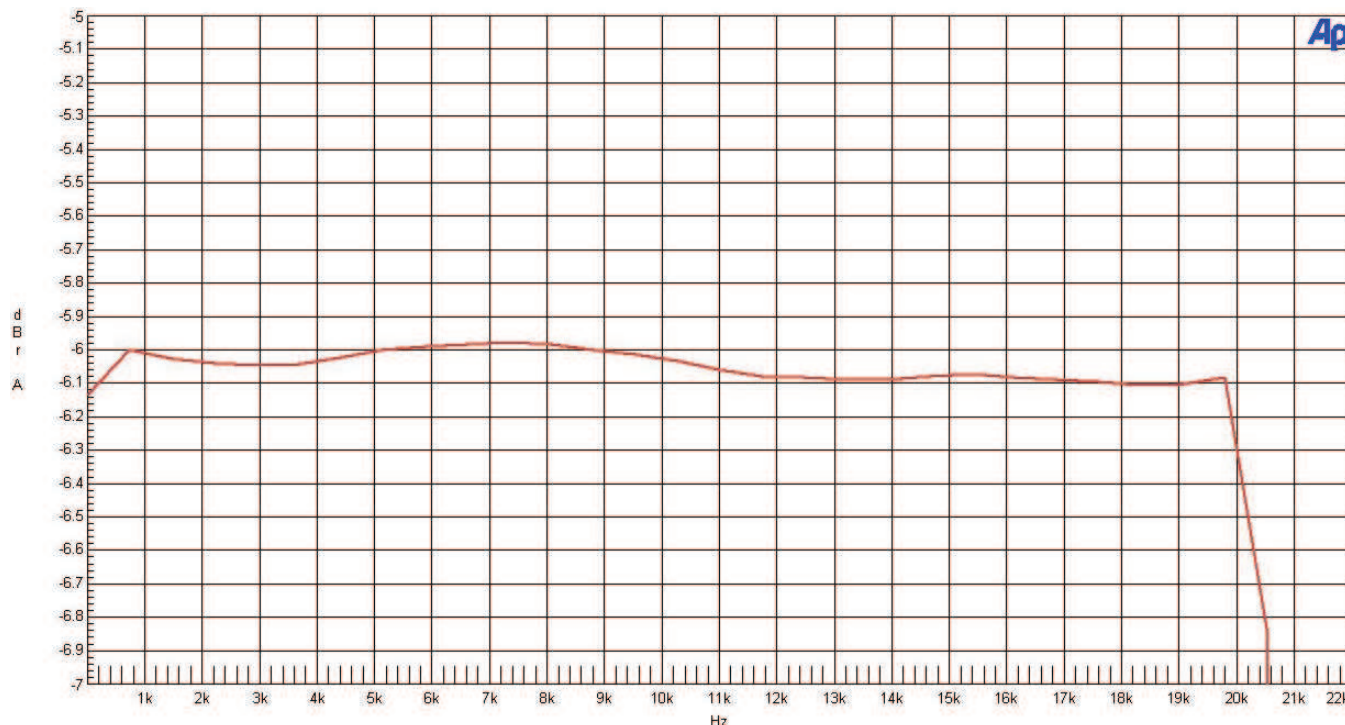

Figure 11-1. Frequency Response (ADC-DAC)

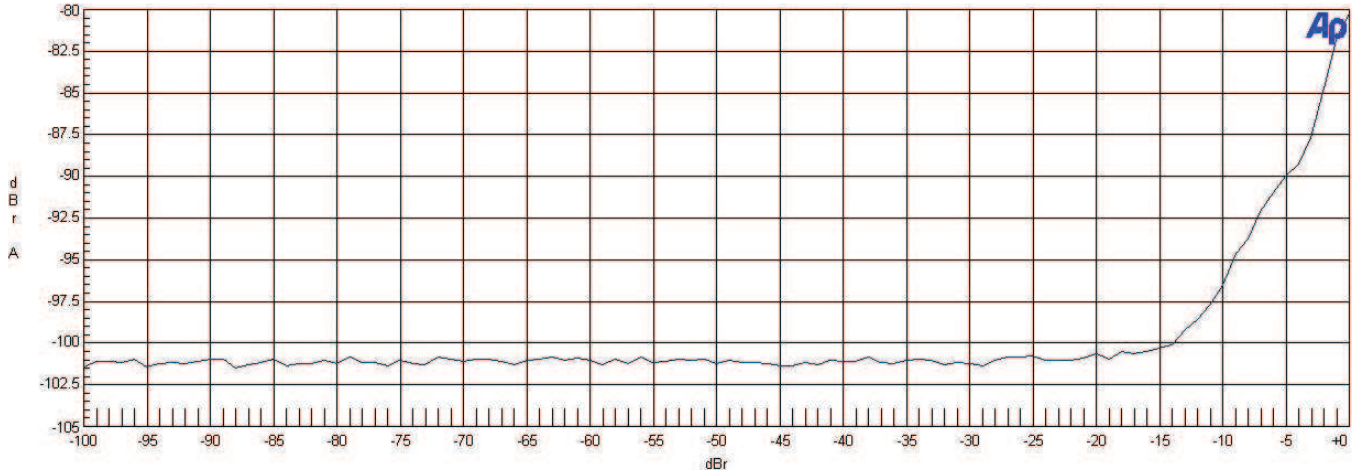

Figure 11-2. THD+N (ADC-DAC)

11.6 Timing Characteristics

The following sections describe the timing characteristics of the TAS3204.

11.7 Master Clock

over recommended operating conditions (unless otherwise noted)

PARAMETER		TEST CONDITIONS	MIN	TYP	MAX	UNIT
$f_{(XTAL_IN)}$	Frequency, XTAL_IN ($1/ t_{c(1)}$)	See ⁽¹⁾		512Fs		Hz
$t_{c(1)}$	Cycle time, XTAL_IN			1÷512Fs		Sec
$f_{(MCLK_IN)}$	Frequency, MCLK_IN ($1/ t_{c(2)}$)			512Fs		Hz
$t_{w(MCLK_IN)}$	Pulse duration, MCLK_IN high	See ⁽²⁾	0.4 $t_{c(2)}$	0.5 $t_{c(2)}$	0.6 $t_{c(2)}$	ns
	Crystal frequency deviation				50	ppm
$f_{(MCLKO)}$	Frequency, MCLKO ($1/ t_{c(3)}$)			256Fs		Hz
$t_{r(MCLKO)}$	Rise time, MCLKO	$C_L = 30$ pF			15	ns
$t_{f(MCLKO)}$	Fall time, MCLKO	$C_L = 30$ pF			15	ns
$t_{w(MCLK_IN)}$	Pulse duration, MCLKO high	See ⁽³⁾		H_{MCLKO}		ns
MCLKO jitter	XTAL_IN master clock source			80		ps
	MCLK_IN master clock source	See ⁽⁴⁾				ps
$t_{d(MI-MO)}$	Delay time, MCLK_IN rising edge to MCLKO rising edge	MCLKO = MCLK_IN	See ⁽⁵⁾		20	ns
		MCLKO < MCLK_IN	See ⁽⁵⁾ ⁽⁶⁾		20	ns

(1) Duty cycle is 50/50.

(2) Period of MCLK_IN = $T_{MCLK_IN} = 1/f_{MCLK_IN}$

(3) $H_{MCLKO} = 1/(2 \times MCLKO)$. MCLKO has the same duty cycle as MCLK_IN when MCLKO = MCLK_IN. When MCLKO = 0.5 MCLK_IN or 0.25 MCLK_IN, the duty cycle of MCLKO is typically 50%.

(4) When MCLKO is derived from MCLK_IN, MCLKO jitter = MCLK_IN jitter

(5) Only applies when MCLK_IN is selected as master source clock

(6) Also applies to MCLKO falling edge when MCLKO = MCLK_IN/2 or MCLK_IN/4

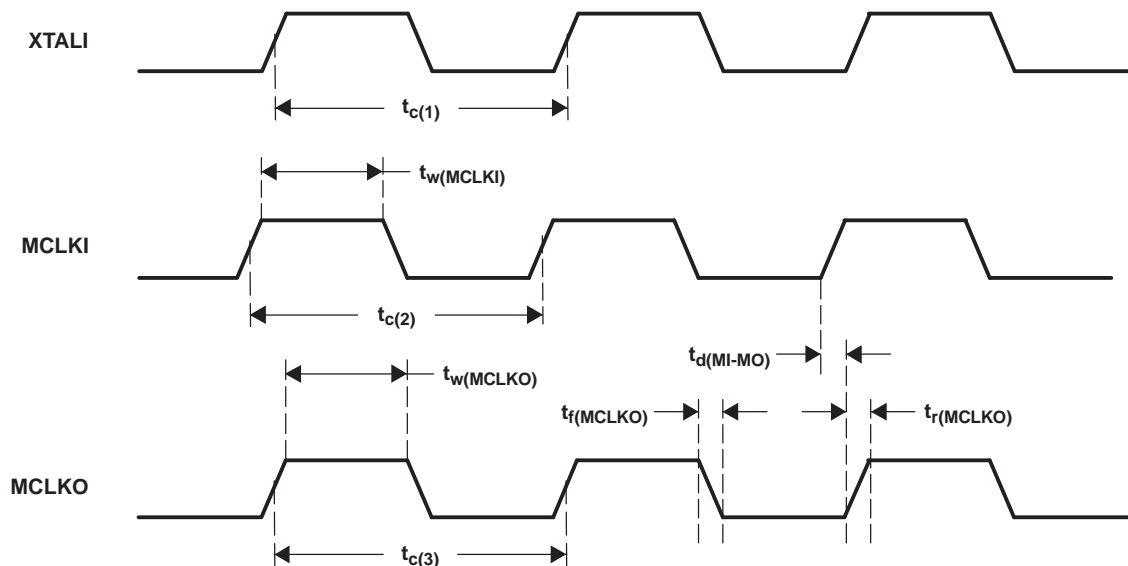

T0088-01

Figure 11-3. Master Clock Signal Timing Waveforms

11.8 Serial Audio Port, Slave Mode

over recommended operating conditions (unless otherwise noted)

PARAMETER	TEST CONDITIONS	MIN	TYP	MAX	UNIT	
f_{LRCLK}	Frequency, LRCLK (f_S)			48	kHz	
$t_{w(SCLKIN)}$	Pulse duration, SCLKIN high	See ⁽¹⁾	$0.4 t_{c(SCLKIN)}$	$0.5 t_{c(SCLKIN)}$	$0.6 t_{c(SCLKIN)}$	ns
f_{SCLKIN}	Frequency, SCLKIN	See ⁽²⁾	$64 F_S$		MHz	
$t_{pBit 1}$	Propagation delay, SCLKIN falling edge to SDOUT			16	ns	
t_{su1}	Setup time, LRCLK to SCLKIN rising edge	10			ns	
t_{h1}	Hold time, LRCLK from SCLKIN rising edge	5			ns	
t_{su2}	Setup time, SDIN to SCLKIN rising edge	10			ns	
t_{h2}	Hold time, SDIN from SCLKIN rising edge	5			ns	
$t_{pBit 2}$	Propagation delay, SCLKIN falling edge to SCLKOUT2 falling edge			15	ns	

- (1) Period of SCLKIN = $T_{SCLKIN} = 1/f_{SCLKIN}$
- (2) Duty cycle is 50/50.

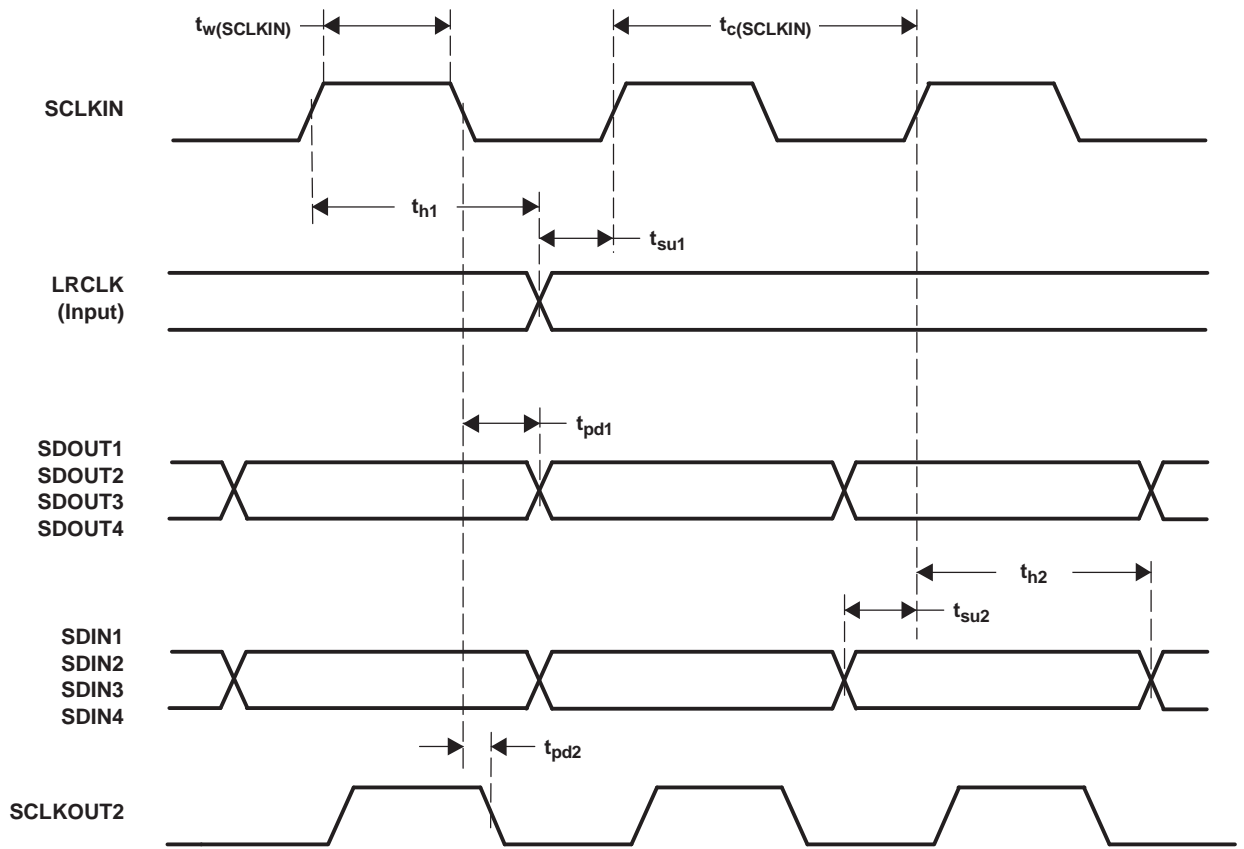

T0090-01

Figure 11-4. Serial Audio Port Slave Mode Timing Waveforms

11.9 Serial Audio Port Master Mode Signals (TAS3204)

over recommended operating conditions (unless otherwise noted)

PARAMETER		TEST CONDITIONS	MIN	TYP	MAX	UNIT
$f_{(LRCLK)}$	Frequency LRCLK	$C_L = 30 \text{ pF}$		48		kHz
$t_{r(LRCLK)}$	Rise time, LRCLK ⁽¹⁾	$C_L = 30 \text{ pF}$			12	ns
$t_{f(LRCLK)}$	Fall time, LRCLK ⁽¹⁾	Duty cycle is 50/50			12	ns
$f_{(SCLKOUT)}$	Frequency, SCLKOUT	$C_L = 30 \text{ pF}$		$64F_S$		MHz
$t_{r(SCLKOUT)}$	Rise time, SCLKOUT	$C_L = 30 \text{ pF}$			12	ns
$t_{f(SCLKOUT)}$	Fall time, SCLKOUT	$C_L = 30 \text{ pF}$			12	ns
$t_{pBit 1(SCLKOUT)}$	Propagation delay, SCLKOUT falling edge to LRCLK edge				5	ns
$t_{pBit 2}$	Propagation delay, SCLKOUT falling edge to SDOUT1-2				5	ns
t_{su}	Setup time, SDIN to SCLKOUT rising edge		25			ns
t_h	Hold time, SDIN from SCLKOUT rising edge		30			ns

(1) Rise time and fall time measured from 20% to 80% of maximum height of waveform.

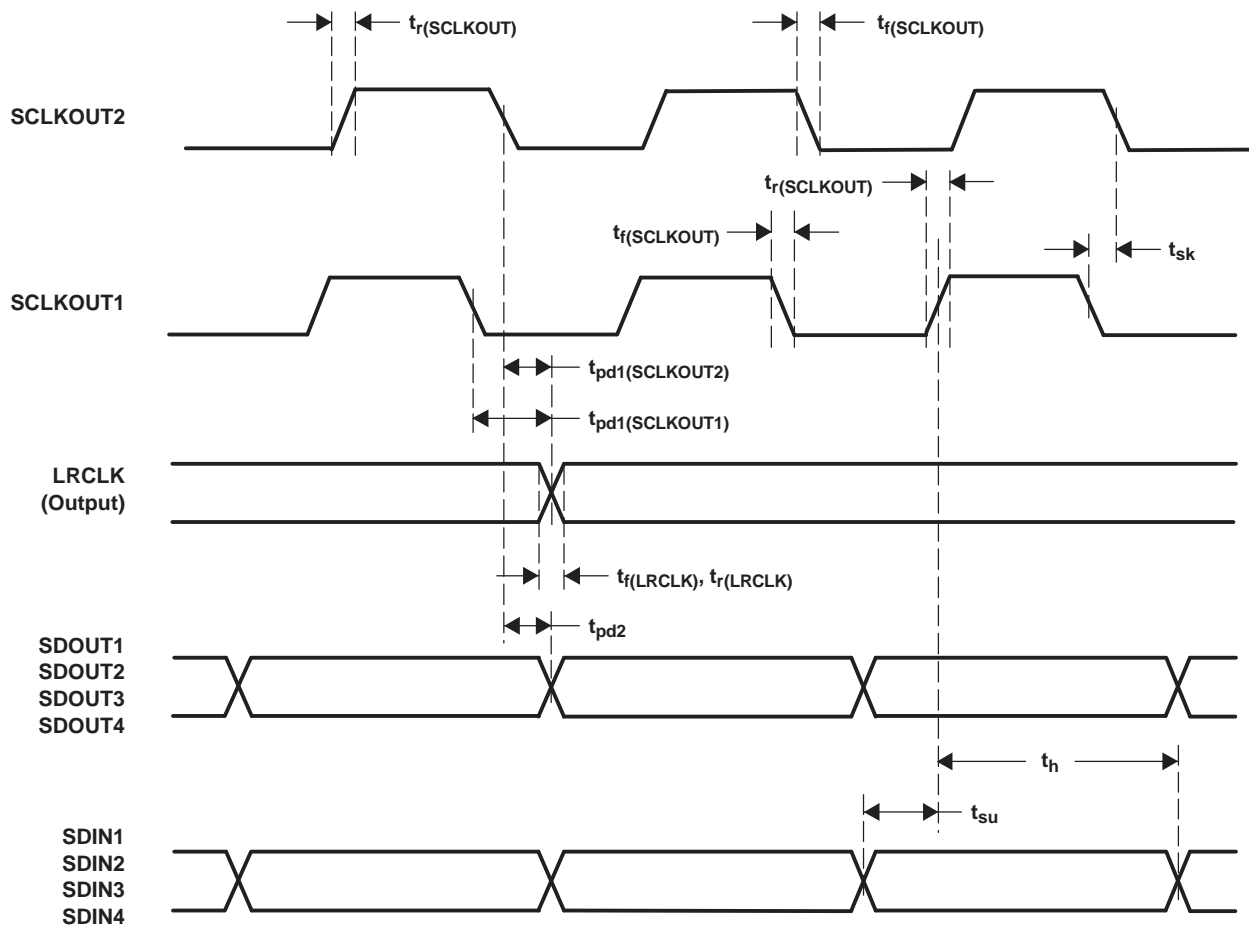

T0091-01

Figure 11-5. Serial Audio Port Master Mode Timing Waveforms

11.10 Pin-Related Characteristics of the SDA and SCL I/O Stages for F/S-Mode I²C-Bus Devices

PARAMETER	TEST CONDITIONS	STANDARD MODE		FAST MODE		UNIT
		MIN	MAX	MIN	MAX	
V _{IL}	LOW-level input voltage	-0.5	0.8	-0.5	0.8	V
V _{IH}	HIGH-level input voltage	2		2		V
V _{hys}	Hysteresis of inputs	N/A	N/A	0.05 V _{DD}		V
V _{OL1}	LOW-level output voltage (open drain or open collector)	3-mA sink current		0	0.4	V
t _{of}	Output fall time from V _{IHmin} to V _{ILmax}	Bus capacitance from 10 pF to 400 pF		7 + 0.1 C _{b(1)}	250	ns
I _I	Input current, each I/O pin	-10	10	-10 ⁽²⁾	10 ⁽²⁾	μA
t _{SP(SCL)}	SCL pulse duration of spikes that must be suppressed by the input filter	N/A	N/A	14 ⁽³⁾		ns
t _{SP(SDA)}	SDA pulse duration of spikes that must be suppressed by the input filter	N/A	N/A	22 ⁽³⁾		ns
C _I	Capacitance, each I/O pin		10		10	pF

(1) C_b = capacitance of one bus line in pF. The output fall time is faster than the standard I²C specification.

(2) The I/O pins of fast-mode devices must not obstruct the SDA and SCL lines if V_{DD} is switched off.

(3) These values are valid at the 135-MHz DSP clock rate. If DSP clock is reduced by half, the t_{SP} doubles.

11.11 Bus-Related Characteristics of the SDA and SCL I/O Stages for F/S-Mode I²C-Bus Devices

all values are referred to V_{IHmin} and V_{ILmax} (see Section 11.10)

PARAMETER	STANDARD MODE		FAST MODE		UNIT
	MIN	MAX	MIN	MAX	
f _{SCL}	SCL clock frequency		0	400 ⁽¹⁾	kHz
t _{HD-STA}	Hold time (repeated) START condition. After this period, the first clock pulse is generated.		4	0.6	μs
t _{LOW}	LOW period of the SCL clock		4.7	1.3	μs
t _{HIGH}	HIGH period of the SCL clock		4	0.6	μs
t _{SU-STA}	Setup time for repeated START		4.7	0.6	μs
t _{SU-DAT}	Data setup time		250	100	μs
t _{HD-DAT}	Data hold time ⁽²⁾ ⁽³⁾		0	0.9	μs
t _r	Rise time of both SDA and SCL signals			20 + 0.1 C _b ⁽⁴⁾	ns
t _f	Fall time of both SDA and SCL			20 + 0.1 C _b ⁽⁴⁾	ns
t _{SU-STO}	Setup time for STOP condition		4	0.6	μs
t _{BUF}	Bus free time between a STOP and START condition		4.7	1.3	μs
C _b	Capacitive load for each bus line		400	400	pF
V _{nL}	Noise margin at the LOW level for each connected device (including hysteresis)		0.1V _{DVDD}	0.1V _{DVDD}	V
V _{nH}	Noise margin at the HIGH level for each connected device (including hysteresis)		0.2V _{DVDD}	0.2V _{DVDD}	V

(1) In master mode, the maximum speed is 375 kHz.

(2) Note that SDA does not have the standard I²C specification 300-ns internal hold time. SDA must be valid by the rising and falling edges of SCL. TI recommends that a 2-kΩ pullup resistor be used to avoid potential timing issues.

(3) A fast-mode I²C-bus device can be used in a standard-mode I²C-bus system, but the requirement t_{SU-DAT} ≥ 250 ns must then be met. This is automatically the case if the device does not stretch the LOW period of the SCL signal. If such a device does stretch the LOW period of the SCL signal, it must output the next data bit to the SDA line t_{r-max} + t_{SU-DAT} = 1000 + 250 = 1250 ns (according to the standard-mode I²C bus specification) before the SCL line is released.

(4) C_b = total capacitance of one bus line in pF

11.12 Reset Timing

control signal parameters over recommended operating conditions (unless otherwise noted)

PARAMETER		MIN	MAX	UNIT
$t_{w(RESSET)}$	Pulse duration, RESET active	200		ns
$t_{r(DMSTATE)}$	Time to outputs inactive		100	μ s
$t_{r(run)}$	Time to enable I ² C	50		ms

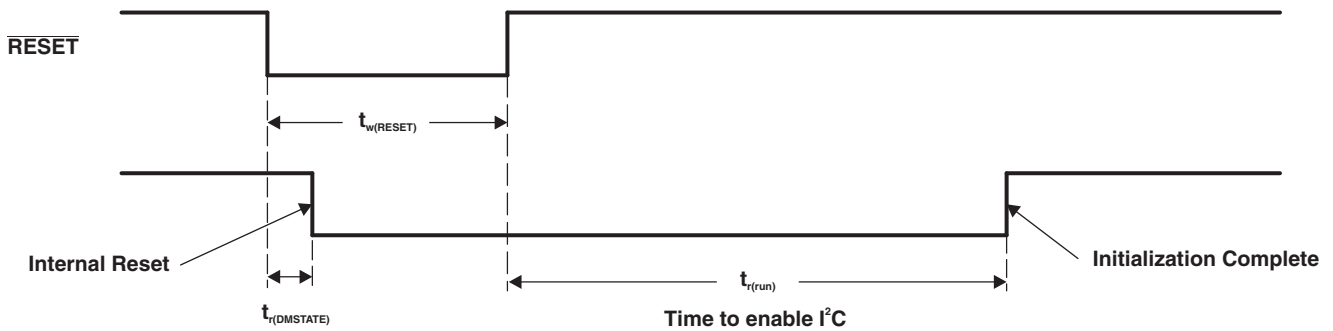

Figure 11-9. Reset Timing

12 I²C Register Map

The following I²C registers are software mapped to some of the Extended Special Function Registers (ESFR) via the ROM code. Table 14-1 lists the I²C sub-address that are configured for these registers if the TAS3204 MCU is executing the code stored in the ROM.

It should be noted that these I²C subaddresses are reconfigurable, thus if the TAS3204 MCU is executing custom code or code generated from the PurePath Studio™ Graphical Development Environment, the I²C subaddresses listed in Table 14-1 may not be valid. Refer to the PurePath Studio™ Graphical Development Environment(GDE) User's Guide for details regarding how to determine which I²C subaddress valid and how to access the registers that are remapped by the GDE.

Table 12-1. I²C Register Map

SUBADDRESS	REGISTER NAME	NO. OF BYTES	CONTENTS	INITIALIZATION VALUE
0x00	Clock and SAP Control Register	4	Description shown in Section 12.1	0x00, 0x40, 0x1B, 0x22
0x01	Reserved	4	Reserved	0x00, 0x00, 0x00, 0x40
0x02	Status Register	4	Description shown in Section 12.3	0x00, 0x00, 0x03, 0xFF
0x03	Unused			0x00, 0x00, 0x00, 0x00
0x04	I ² C Memory Load Control	8	Description shown in Section 12.4	0x00, 0x00, 0x00, 0x00 0x00, 0x00, 0x00, 0x00
0x05	I ² C Memory Load Data	8	Description shown in Section 12.4	0x00, 0x00, 0x00, 0x00 0x00, 0x00, 0x00, 0x00
0x06	Memory Select and Address	4	u(31:24) ⁽¹⁾ , MemSelect(23:16), Addr(15:8), Addr(7:0)	0x00, 0x00, 0x00, 0x00
0x07	Data Register	16	D(63:56), D(55:48), D(47:40), D(39:32), D(31:24), D(23:16), D(15:8), D(7:0)	0x00, 0x00, 0x00, 0x00 0x00, 0x00, 0x00, 0x00
0x08	Device Version	4	TAS3204 version	0x00, 0x00, 0x00, 0x01
0x09	Unused	Unused	Unused	Unused
0x10	Analog Power Down Control 1	4	Analog Power Down Control 1	0x00, 0x00, 0x00, 0x1F
0x11	Analog Power Down Control 2	4	Analog Power Down Control 2	0x00, 0x00, 0x00, 0xFF
0x12	Analog Input Control	4	Analog Input Control	0x00, 0x00, 0x00, 0x01
0x13	ADC Dynamic Element Matching	4	ADC Dynamic Element Matching	0x00, 0x00, 0x00, 0x08
0x14	ADC2 Current Control 1	4	ADC1 Current Control 1	0x00, 0x00, 0x00, 0x00
0x15	ADC2 Current Control 2	4	ADC1 Current Control 2	0x00, 0x00, 0x00, 0x00
0x16	Unused		Unused	
0x17	ADC1 Current Control 1	4	ADC2 Current Control 1	0x00, 0x00, 0x00, 0x00
0x18	ADC1 Current Control 2	4	ADC2 Current Control 2	0x00, 0x00, 0x00, 0x00
0x19	Unused	4	Unused	
0x1A	DAC Control 1	4	DAC Control 1	0x00, 0x00, 0x00, 0x00
0x1B	DAC Control 2	4	DAC Control 2	0x00, 0x00, 0x00, 0x00
0x1C	Analog Test Modes	4	Analog Test Modes	0x00, 0x00, 0x00, 0x00
0x1D	DAC Modulator Dither	4	DAC Modulator Dither	0x00, 0x00, 0x00, 0x00
0x1E	ADC/DAC Digital Reset	4	ADC/DAC Digital Reset	0x00, 0x00, 0x00, 0x00
0x1F	Analog Input Gain Select		Analog Input Gain Select	0x00, 0x00, 0x00, 0x00
0x20	Clock Delay Setting ADC	4	Clock Delay Setting ADC	0x00, 0x00, 0x00, 0x00
0x21	MCLK_OUT2 Divider	4	MCLK_OUT2 Divider	0x00, 0x00, 0x00, 0x05
0x22	MCLK_OUT3 Divider	4	MCLK_OUT3 Divider	0x00, 0x00, 0x00, 0x00
0x23	Bypass Time	4	Bypass Time	0x00, 0x00, 0x00, 0x00
0x24	Clock Delay Setting DAC	4	Clock Delay Setting DAC	0x00, 0x00, 0x00, 0x00
0x30–0x3F	Digital Cross Bar	32	Digital Cross Bar	See Section 12.15

(1) u indicates unused bits.

In the following sections, **BOLD** indicates the default state of the bit fields.

12.1 Clock Control Register (0x00)

Register 0x00 provides the user with control over MCLK, LRCLK, SCLKOUT1, SCLKOUT2, data-word size, and serial audio port modes. Register 0x00 default = **0x00 00 1B 22**.

Table 12-2. Clock Control Register (0x00)

Bit 31	Bit 30	Bit 29	Bit 28	Bit 27	Bit 26	Bit 25	Bit 24	DESCRIPTION
–	–	–	–	–	–	–	–	Firmware definable
Bit 23	Bit 22	Bit 21	Bit 20	Bit 19	Bit 18	Bit 17	Bit 16	DESCRIPTION
–	1	–	–	–	–	–	–	Master Mode (XTAL)
–	0	–	–	–	–	–	–	Slave mode (MCLK_IN)
Bit 15	Bit 14	Bit 13	Bit 12	Bit 11	Bit 10	Bit 9	Bit 8	DESCRIPTION
–	–	–	–	–	–	0	0	Output SAP 32 bit word
–	–	–	–	–	–	0	1	Output SAP 16 bit word
–	–	–	–	–	–	1	0	Output SAP 20 bit word
–	–	–	–	–	–	1	1	Output SAP 24 bit word
–	–	–	0	0	–	–	–	Input SAP 32 bit word
–	–	–	0	1	–	–	–	Input SAP 16 bit word
–	–	–	1	0	–	–	–	Input SAP 20 bit word
–	–	–	1	1	–	–	–	Input SAP 24 bit word
Bit 7	Bit 6	Bit 5	Bit 4	Bit 3	Bit 2	Bit 1	Bit 0	DESCRIPTION
IM3	IM2	IM1	IM0					Input data format
				OM3	OM2	OM1	OM0	Output data format

12.2 MCUcontroller Clock Control Register

This register is reserved.

12.3 Status Register (0x02)

The Status Register provides memory load information. When a memory load error from a particular memory occurs or immediately after the start of a memory load, the memory load error bit for that particular memory is set to 1. When a memory load is successful for a particular memory, the error bit is cleared. The host needs to check this load status after each memory load. These bits can be cleared by firmware.

Table 12-3. Status Register (0x02)

Bit 31	Bit 30	Bit 29	Bit 28	Bit 27	Bit 26	Bit 25	Bit 24	DESCRIPTION
–	–	–	–	–	–	–	–	Firmware definable
Bit 23	Bit 22	Bit 21	Bit 20	Bit 19	Bit 18	Bit 17	Bit 16	DESCRIPTION
–	–	–	–	–	–	–	–	Firmware definable
Bit 15	Bit 14	Bit 13	Bit 12	Bit 11	Bit 10	Bit 9	Bit 8	DESCRIPTION
–	–	–	–	–	–	–	–	Firmware definable
Bit 7	Bit 6	Bit 5	Bit 4	Bit 3	Bit 2	Bit 1	Bit 0	DESCRIPTION
0	0	–	–	–	–	–	1	MCU program memory load error
0	0	–	–	–	–	1	–	MCU external data memory load error
0	0	–	–	–	1	–	–	Audio DSP core program memory load error
0	0	–	–	1	–	–	–	Audio DSP core upper coefficient memory load error
0	0	–	1	–	–	–	–	Audio DSP core upper data memory load error
0	0	1	–	–	–	–	–	Invalid memory select
1	1	1	1	0	0	0	0	End-of-load header error
1	1	1	1	1	1	1	1	N, IC sampling clock is 33 MHz divided by 2N
0	0	0	0	0	0	0	0	No errors

12.4 I²C Memory Load Control and Data Registers (0x04 and 0x05)

Registers 0x04 (Table 12-4) and 0x05 (Table 12-5) allow the user to download TAS3204 program code and data directly from the system I²C controller.

The I²C slave memory load port permits the system controller to load the TAS3204 memories as an alternative to having the TAS3204 load its memory from EEPROM.

- MCU program memory
- MCU extended memory
- DAP program memory
- DAP coefficient memory
- DAP data memory

The transfer is performed by writing to two I²C registers. The first register is a eight byte register that holds the checksum, the memory to be written, the starting address, the number of data bytes to be transferred. The second location holds 8 bytes of data. The memory load operation starts with the first register being set. Then the data is written into the second register using the format shown. After the last data byte is written into the second register, an additional two bytes are written which contain the two-byte checksum. At that point, the transfer is complete and status of the operation is reported in the status register. The end checksum is always contained in the last two bytes of the data block.

Table 12-4. TAS3204 Memory Load Control Register (0x04)

BYTE	DATA BLOCK FORMAT	SIZE	NOTES
1-2	Checksum code	2 bytes	Checksum of bytes 2 through N + 8. If this is a termination header, this value is 00 00.
3	Memory to be loaded	1 byte	0: MCU program memory 1: MCU external data memory 2: Audio DSP core program memory 3: Audio DSP core coefficient memory 4: Audio DSP core data memory 5: Audio DSP core upper data memory 6: Audio DSP core upper coefficient memory 7–15: Reserved for future expansion
4	Unused	1 byte	Reserved for future expansion
5–6	Starting TAS3204 memory address	2 bytes	If this is a termination header, this value is 0000.
7–8	Number of data bytes to be transferred	2 bytes	If this is a termination header, this value is 0000.

Table 12-5. TAS3204 Memory Load Data Register (0x05)

BYTE	8-BIT DATA	28-BIT DATA	48-BIT DATA	54-BIT DATA
1	Datum 1 Bit 7–Bit 0	0000 Bit 27–Bit 24	0000 0000	0000 0000
2	Datum 2 Bit 7–Bit 0	Bit 7–Bit 0	0000 0000	00 Bit 53–Bit 48
3	Datum 3 Bit 7–Bit 0	Bit 15–D8	Bit 47–Bit 40	Bit 47–Bit 40
4	Datum 4 Bit 7–Bit 0	Bit 7–Bit 0	Bit 39–Bit 32	Bit 39–Bit 32
5	Datum 5 Bit 7–Bit 0	0000 Bit 27–Bit 24	Bit 31–Bit 24	Bit 31–Bit 24
6	Datum 6 Bit 7–Bit 0	Bit 23–Bit 16	Bit 23–Bit 16	Bit 23–Bit 16
7	Datum 7 Bit 7–Bit 0	Bit 15–D8	Bit 15–D8	Bit 15–D8
8	Datum 8 Bit 7–Bit 0	Bit 7–Bit 0	Bit 7–Bit 0	Bit 7–Bit 0

12.5 Memory Access Registers (0x06 and 0x07)

Registers 0x06 (Table 12-6) and 0x07 (Table 12-7) allow the user to access the internal resources of the TAS3204. See *TAS3108/TAS3108IA Firmware Programmer's Guide* (SLEU067) for more details.

Table 12-6. Memory Select and Address Register (0x06)

Bit 31	Bit 30	Bit 29	Bit 28	Bit 27	Bit 26	Bit 25	Bit 24	DESCRIPTION
–	–	–	–	–	–	–	–	Unused
Bit 23	Bit 22	Bit 21	Bit 20	Bit 19	Bit 18	Bit 17	Bit 16	DESCRIPTION
0	0	0	0	0	0	0	1	Audio DSP core coefficient memory select
0	0	0	0	0	0	1	0	Audio DSP core data memory select
0	0	0	0	0	0	1	1	Reserved
0	0	0	0	0	1	0	0	MCU internal data memory select
0	0	0	0	0	1	0	1	MCU external data memory select
0	0	0	0	0	1	1	0	SFR select
0	0	0	0	0	1	1	1	MCU program RAM select
0	0	0	0	1	0	0	0	Audio DSP core program RAM select
0	0	0	0	1	0	0	1	Audio DSP core upper memory select
0	0	0	0	1	0	1	0	Audio DSP core program RAM select
Bit 15	Bit 14	Bit 13	Bit 12	Bit 11	Bit 10	Bit 9	Bit 8	DESCRIPTION
A0	A1	A2	A3	A4	A5	A6	A7	Memory address
Bit 7	Bit 6	Bit 5	Bit 4	Bit 3	Bit 2	Bit 1	Bit 0	DESCRIPTION
A8	A9	A10	A11	A12	A13	A14	A15	Memory address

Table 12-7. Data Register (Peek and Poke) (0x07)

Bit 63	Bit 62	Bit 61	Bit 60	Bit 59	Bit 58	Bit 57	Bit 56	DESCRIPTION
Bit 63	Bit 62	Bit 61	Bit 60	Bit 59	Bit 58	Bit 57	Bit 56	Data to be written or read
Bit 55	Bit 54	Bit 53	Bit 52	Bit 51	Bit 50	Bit 49	Bit 48	DESCRIPTION
Bit 55	Bit 54	Bit 53	Bit 52	Bit 51	Bit 50	Bit 49	Bit 48	Data to be written or read
Bit 47	Bit 46	Bit 45	Bit 44	Bit 43	Bit 42	Bit 41	Bit 40	DESCRIPTION
Bit 47	Bit 46	Bit 45	Bit 44	Bit 43	Bit 42	Bit 41	Bit 40	Data to be written or read
Bit 39	Bit 38	Bit 37	Bit 36	Bit 35	Bit 34	Bit 33	Bit 32	DESCRIPTION
Bit 39	Bit 38	Bit 37	Bit 36	Bit 35	Bit 34	Bit 33	Bit 32	Data to be written or read
Bit 31	Bit 30	Bit 29	Bit 28	Bit 27	Bit 26	Bit 25	Bit 24	DESCRIPTION
Bit 31	Bit 30	Bit 29	Bit 28	Bit 27	Bit 25	Bit 26	Bit 25	Data to be written or read
Bit 23	Bit 22	Bit 21	Bit 20	Bit 19	Bit 18	Bit 17	Bit 16	DESCRIPTION
Bit 23	Bit 22	Bit 21	Bit 20	Bit 19	Bit 18	Bit 17	Bit 16	Data to be written or read
Bit 15	Bit 14	Bit 13	Bit 12	Bit 11	Bit 10	D9	D8	DESCRIPTION
Bit 15	Bit 14	Bit 13	Bit 12	Bit 11	Bit 10	D9	D8	Data to be written or read
Bit 7	Bit 6	Bit 5	Bit 4	Bit 3	Bit 2	Bit 1	Bit 0	DESCRIPTION
Bit 7	Bit 6	Bit 5	Bit 4	Bit 3	Bit 2	Bit 1	Bit 0	Data to be written or read

12.6 Device Version (0x08)

Table 12-8. Device Version

Bit 31	Bit 30	Bit 29	Bit 28	Bit 27	Bit 26	Bit 25	Bit 24	DESCRIPTION
–	–	–	–	–	–	–	–	Firmware definable
Bit 23	Bit 22	Bit 21	Bit 20	Bit 19	Bit 18	Bit 17	Bit 16	DESCRIPTION
–	–	–	–	–	–	–	–	Firmware definable
Bit 15	Bit 14	Bit 13	Bit 12	Bit 11	Bit 10	D9	D8	DESCRIPTION
–	–	–	–	–	–	–	–	Firmware definable
Bit 7	Bit 6	Bit 5	Bit 4	Bit 3	Bit 2	Bit 1	Bit 0	DESCRIPTION
0	0	0	0	0	0	0	1	TAS3204 device version

12.7 Analog Power Down Control (0x10 and 0x11)

Table 12-9. Analog Power Down Control 1 (0x10)

Bit 7	Bit 6	Bit 5	Bit 4	Bit 3	Bit 2	Bit 1	Bit 0	DESCRIPTION
–	–	–	–	–	–	–	1	Central reference enable
–	–	–	–	–	–	–	0	Power down central reference
–	–	–	–	–	–	1	–	ADC1 enable
–	–	–	–	–	–	0	–	ADC1 power down
–	–	–	–	–	1	–	–	ADC2 enable
–	–	–	–	–	0	–	–	ADC2 power down
–	–	–	–	1	–	–	–	ADC reference enable
–	–	–	–	0	–	–	–	ADC reference power down
–	–	–	1	–	–	–	–	DAC reference enable
–	–	–	0	–	–	–	–	DAC reference power down

Table 12-10. Analog Power Down Control 2 (0x11)

Bit 7	Bit 6	Bit 5	Bit 4	Bit 3	Bit 2	Bit 1	Bit 0	DESCRIPTION
–	–	–	–	–	–	–	1	DAC1 left enable
–	–	–	–	–	–	–	0	DAC1 left power down
–	–	–	–	–	–	1	–	DAC1 right enable
–	–	–	–	–	–	0	–	DAC1 right power down
–	–	–	–	–	1	–	–	DAC2 left enable
–	–	–	–	–	0	–	–	DAC2 left power down
–	–	–	–	1	–	–	–	DAC2 right enable
–	–	–	–	0	–	–	–	DAC2 right power down
–	–	–	1	–	–	–	–	Line out 1 left enable
–	–	–	0	–	–	–	–	Line out 1 left power down
–	–	1	–	–	–	–	–	Line out 1 right enable
–	–	0	–	–	–	–	–	Line out 1 right power down
–	1	–	–	–	–	–	–	Line out 2 left enable
–	0	–	–	–	–	–	–	Line out 2 left power down
1	–	–	–	–	–	–	–	Line out 2 right enable
0	–	–	–	–	–	–	–	Line out 2 right power down

12.8 Analog Input Control (0x12)

Table 12-11. Analog Input Control 3 (0x12)

Bit 7	Bit 6	Bit 5	Bit 4	Bit 3	Bit 2	Bit 1	Bit 0	DESCRIPTION
–	–	–	–	–	–	–	0	–
–	–	–	–	–	–	–	1	Select input 1 to ADC 1
–	–	–	–	–	–	0	–	–
–	–	–	–	–	–	1	–	Select input 1 to ADC 2
–	–	–	–	–	0	–	–	–
–	–	–	–	–	1	–	–	Select input 2 to ADC 2
–	–	–	–	0	–	–	–	–
–	–	–	–	1	–	–	–	Select input 2 to ADC 2
–	–	–	0	–	–	–	–	–
–	–	–	1	–	–	–	–	Select input 3 to ADC 2
–	–	0	–	–	–	–	–	–
–	–	1	–	–	–	–	–	Select input 3 to ADC 2
–	0	–	–	–	–	–	–	ADC 1 differential input
–	1	–	–	–	–	–	–	ADC 1 single ended input
0	–	–	–	–	–	–	–	ADC 2 differential input
1	–	–	–	–	–	–	–	ADC 2 single ended input

12.9 Dynamic Element Matching (0x13)

Table 12-12. Dynamic Element Matching (0x13)

Bit 7	Bit 6	Bit 5	Bit 4	Bit 3	Bit 2	Bit 1	Bit 0	DESCRIPTION
–	–	–	–	–	–	–	0	ADC dynamic element matching algorithm enabled (recommended setting)
–	–	–	–	–	–	–	1	ADC dynamic element matching algorithm disabled
–	–	–	–	–	–	0	–	Dynamic weighted averaging enabled (recommended setting)
–	–	–	–	–	–	1	–	Dynamic weighted averaging disabled
–	–	–	–	–	0	–	–	Unused
–	–	–	–	–	1	–	–	Unused
–	–	–	–	0	–	–	–	Fast charge of cap on VREF (filtering disabled – recommended setting at startup)
–	–	–	–	1	–	–	–	Slow charge of cap on VREF (filtering enabled – recommended setting during normal operation)
–	–	–	0	–	–	–	–	Unused
–	–	–	1	–	–	–	–	Unused
–	–	0	–	–	–	–	–	Unused
–	–	1	–	–	–	–	–	Unused
–	0	–	–	–	–	–	–	Unused
–	1	–	–	–	–	–	–	Unused
0	–	–	–	–	–	–	–	Unused
1	–	–	–	–	–	–	–	Unused

12.10 Current Control Select (0x14, 0x15, 0x17, 0x18)

Table 12-13. Current Control Select 1(0x14)

Bit 7	Bit 6	Bit 5	Bit 4	Bit 3	Bit 2	Bit 1	Bit 0	DESCRIPTION
–	–	–	–	–	–	0	0	ADC2 summer current setting (left and right) = 130% of nominal current (recommended setting)
–	–	–	–	–	–	0	1	ADC2 summer current setting (left and right) = 100% of nominal current
–	–	–	–	–	–	1	0	ADC2 summer current setting (left and right) = 100% of nominal current
–	–	–	–	–	–	1	1	ADC2 summer current setting (left and right) = 70% of nominal current
–	–	–	–	0	0	–	–	ADC2 quantizer current setting (left and right) = 137.5% of nominal current (recommended setting)
–	–	–	–	0	1	–	–	ADC2 quantizer current setting (left and right) = 100% of nominal current
–	–	–	–	1	0	–	–	ADC2 quantizer current setting (left and right) = 100% of nominal current
–	–	–	–	1	1	–	–	ADC2 quantizer current setting (left and right) = 62.5% of nominal current
–	–	0	0	–	–	–	–	ADC2 third integrator current setting (left and right) = 130% of nominal current (recommended setting)
–	–	0	1	–	–	–	–	ADC2 third integrator current setting (left and right) = 100% of nominal current
–	–	1	0	–	–	–	–	ADC2 third integrator current setting (left and right) = 100% of nominal current
–	–	1	1	–	–	–	–	ADC2 third integrator current setting (left and right) = 70% of nominal current
0	0	–	–	–	–	–	–	ADC2 reference buffer current setting (left and right) = 130% of nominal current (recommended setting)
0	1	–	–	–	–	–	–	ADC2 reference buffer current setting (left and right) = 100% of nominal current
1	0	–	–	–	–	–	–	ADC2 reference buffer current setting (left and right) = 100% of nominal current
1	1	–	–	–	–	–	–	ADC2 reference buffer current setting (left and right) = 70% of nominal current

Table 12-14. Current Control Select 2 (0x15)

Bit 7	Bit 6	Bit 5	Bit 4	Bit 3	Bit 2	Bit 1	Bit 0	DESCRIPTION
–	–	–	–	–	–	0	0	ADC2 second integrator current setting (left and right) = 130% of nominal current (recommended setting)
–	–	–	–	–	–	0	1	ADC2 second integrator current setting (left and right) = 100% of nominal current
–	–	–	–	–	–	1	0	ADC2 second integrator current setting (left and right) = 100% of nominal current
–	–	–	–	–	–	1	1	ADC2 second integrator current setting (left and right) = 70% of nominal current
–	–	–	–	0	0	–	–	ADC2 second integrator current setting (left and right) = 130% of nominal current (recommended setting)
–	–	–	–	0	1	–	–	ADC2 first integrator current setting (left and right) = 100% of nominal current
–	–	–	–	1	0	–	–	ADC2 first integrator current setting (left and right) = 100% of nominal current
–	–	–	–	1	1	–	–	ADC2 first integrator current setting (left and right) = 70% of nominal current
–	–	–	0	–	–	–	–	ADC2 current for common mode buffer to integrator 1 = 3.5 μ A
–	–	–	1	–	–	–	–	ADC2 current for common mode buffer to integrator 1 = 2.0 μ A
–	–	0	–	–	–	–	–	ADC2 current for common mode buffer to integrator 2 and 3 = 3.5 μ A
–	–	1	–	–	–	–	–	ADC2 current for common mode buffer to integrator 2 and 3 = 2.0 μ A
–	0	–	–	–	–	–	–	ADC2 current for the buffer to the ADC sampling switches = 3.5 μ A
–	1	–	–	–	–	–	–	ADC2 current for the buffer to the ADC sampling switches = 2.0 μ A
0	–	–	–	–	–	–	–	ADC2 current for the reference buffer to the ADC DAC = 3.5 μ A
1	–	–	–	–	–	–	–	ADC2 Current for the Reference Buffer to The ADC DAC = 2.0 μ A

Table 12-15. Current Control Select 3 (0x17)

Bit 7	Bit 6	Bit 5	Bit 4	Bit 3	Bit 2	Bit 1	Bit 0	DESCRIPTION
–	–	–	–	–	–	0	0	ADC1 summer current setting (left and right) = 130% of nominal current (Recommended Setting)
–	–	–	–	–	–	0	1	ADC1 summer current setting (left and right) = 100% of nominal current
–	–	–	–	–	–	1	0	ADC1 summer current setting (left and right) = 100% of nominal current
–	–	–	–	–	–	1	1	ADC1 summer current setting (left and right) = 70% of nominal current
–	–	–	–	0	0	–	–	ADC1 quantizer current setting (left and right) = 137.5% of nominal current (recommended setting)
–	–	–	–	0	1	–	–	ADC1 quantizer current setting (left and right) = 100% of nominal current
–	–	–	–	1	0	–	–	ADC1 quantizer current setting (left and right) = 100% of nominal current
–	–	–	–	1	1	–	–	ADC1 quantizer current setting (left and right) = 62.5% of nominal current
–	–	0	0	–	–	–	–	ADC1 third integrator current setting (left and right) = 130% of nominal current (Recommended Setting)
–	–	0	1	–	–	–	–	ADC1 third integrator current setting (left and right) = 100% of nominal current
–	–	1	0	–	–	–	–	ADC1 third integrator current setting (left and right) = 100% of nominal current
–	–	1	1	–	–	–	–	ADC1 third integrator current setting (left and right) = 70% of nominal current
0	0	–	–	–	–	–	–	ADC1 reference buffer current setting (left and right) = 130% of nominal current (Recommended Setting)
0	1	–	–	–	–	–	–	ADC1 reference buffer current setting (left and right) = 100% of nominal current
1	0	–	–	–	–	–	–	ADC1 reference buffer current setting (left and right) = 100% of nominal current
1	1	–	–	–	–	–	–	ADC1 reference buffer current setting (left and right) = 70% of nominal current

Table 12-16. Current Control Select 4 (0x18)

Bit 7	Bit 6	Bit 5	Bit 4	Bit 3	Bit 2	Bit 1	Bit 0	DESCRIPTION
–	–	–	–	–	–	0	0	ADC1 second integrator current setting (left and right) = 130% of nominal current (recommended setting)
–	–	–	–	–	–	0	1	ADC1 second integrator current setting (left and right) = 100% of nominal current
–	–	–	–	–	–	1	0	ADC1 second integrator current setting (left and right) = 100% of nominal current
–	–	–	–	–	–	1	1	ADC1 second integrator current setting (left and right) = 70% of nominal current
–	–	–	–	0	0	–	–	ADC1 second integrator current setting (left and right) = 130% of nominal current (recommended setting)
–	–	–	–	0	1	–	–	ADC1 first integrator current setting (left and right) = 100% of nominal current
–	–	–	–	1	0	–	–	ADC1 first integrator current setting (left and right) = 100% of nominal current
–	–	–	–	1	1	–	–	ADC1 first integrator current setting (left and right) = 70% of nominal current
–	–	0	0	–	–	–	–	ADC1 current for common mode buffer to integrator 1 = 3.5 μ A
–	–	0	1	–	–	–	–	ADC1 current for common mode buffer to integrator 1 = 2.0 μ A
–	–	1	0	–	–	–	–	ADC1 current for common mode buffer to integrator 2 and 3 = 3.5 μ A
–	–	1	1	–	–	–	–	ADC1 current for common mode buffer to integrator 2 and 3 = 2.0 μ A
0	0	–	–	–	–	–	–	ADC1 current for the buffer to the ADC sampling switches = 3.5 μ A
0	1	–	–	–	–	–	–	ADC1 current for the buffer to the ADC sampling switches = 2.0 μ A
1	0	–	–	–	–	–	–	ADC1 current for the reference buffer to the ADC DAC = 3.5 μ A
1	1	–	–	–	–	–	–	ADC1 current for the reference buffer to the ADC DAC = 2.0 μ A

12.11 DAC Control (0x1A, 0x1B, 0x1D)

Table 12-17. DAC Control 1 (0x1A)

Bit 7	Bit 6	Bit 5	Bit 4	Bit 3	Bit 2	Bit 1	Bit 0	DESCRIPTION
–	–	–	–	–	–	0	0	DAC1 current control for DAC local reference block and lineout amps = default (recommended setting)
–	–	–	–	–	–	0	1	DAC1 current control for DAC local reference block and lineout amps = 125% bias current
–	–	–	–	–	–	1	0	DAC1 current control for DAC local reference block and lineout amps = 75% bias current
–	–	–	–	–	–	1	1	DAC1 current control for DAC local reference block and lineout amps = 75% bias current
–	–	–	–	0	0	–	–	DAC2 current control for DAC local reference block and lineout amps = default (recommended setting)
–	–	–	–	0	1	–	–	DAC2 current control for DAC local reference block and lineout amps = 125% bias current
–	–	–	–	1	0	–	–	DAC2 current control for DAC local reference block and lineout amps = 75% bias current
–	–	–	–	1	1	–	–	DAC2 current control for DAC local reference block and lineout amps = 75% bias current
–	–	–	–	–	–	–	–	–
–	–	–	–	–	–	–	–	–
–	–	–	–	–	–	–	–	–
–	–	–	–	–	–	–	–	–
–	–	–	–	–	–	–	–	–
–	–	–	–	–	–	–	–	–
–	–	–	–	–	–	–	–	–
–	–	–	–	–	–	–	–	–

Table 12-18. DAC Control 2 (0x1B)

Bit 7	Bit 6	Bit 5	Bit 4	Bit 3	Bit 2	Bit 1	Bit 0	DESCRIPTION
–	–	–	–	–	–	–	0	DAC1 chopper stabilization disable
–	–	–	–	–	–	–	1	DAC1 chopper stabilization enable
–	–	–	–	–	–	0	–	DAC2 chopper stabilization disable
–	–	–	–	–	–	1	–	DAC2 chopper stabilization enable
–	–	–	–	–	0	–	–	DC offset subtraction in DACs 1 and 2 disable
–	–	–	–	–	1	–	–	DC offset subtraction in DACs 1 and 2 enable
–	–	–	–	0	–	–	–	Connected to MCU SDA2
–	–	–	–	1	–	–	–	
–	–	–	–	–	–	–	–	–
–	–	–	–	–	–	–	–	–
–	–	–	–	–	–	–	–	–
–	–	–	–	–	–	–	–	–
–	–	–	–	–	–	–	–	–
–	–	–	–	–	–	–	–	–
–	–	–	–	–	–	–	–	–
–	–	–	–	–	–	–	–	–
–	–	–	–	–	–	–	–	–

Table 12-19. DAC Control 3 (0x1D)

Bit 7	Bit 6	Bit 5	Bit 4	Bit 3	Bit 2	Bit 1	Bit 0	DESCRIPTION
–	–	–	–	–	–	0	0	DAC1 current control for DAC local reference block and lineout amps = default (recommended setting)
–	–	–	–	–	–	0	1	DAC1 current control for DAC local reference block and lineout amps = 125% bias current
–	–	–	–	–	–	1	0	DAC1 current control for DAC local reference block and lineout amps = 75% bias current
–	–	–	–	–	–	1	1	DAC1 current control for DAC local reference block and lineout amps = 75% bias current
–	–	–	–	0	0	–	–	DAC2 current control for DAC local reference block and lineout amps = default (recommended setting)
–	–	–	–	0	1	–	–	DAC2 current control for DAC local reference block and lineout amps = 125% bias current
–	–	–	–	1	0	–	–	DAC2 current control for DAC local reference block and lineout amps = 75% bias current
–	–	–	–	1	1	–	–	DAC2 current control for DAC local reference block and lineout amps = 75% bias current
–	–	–	–	–	–	–	–	–
–	–	–	–	–	–	–	–	–
–	–	–	–	–	–	–	–	–
–	–	–	–	–	–	–	–	–
–	–	–	–	–	–	–	–	–
–	–	–	–	–	–	–	–	–
–	–	–	–	–	–	–	–	–
–	–	–	–	–	–	–	–	–

12.12 ADC and DAC Reset (0x1E)

Table 12-20. ADC and DAC Reset (0x1E)

Bit 7	Bit 6	Bit 5	Bit 4	Bit 3	Bit 2	Bit 1	Bit 0	DESCRIPTION
–	–	–	–	–	–	–	0	–
–	–	–	–	–	–	–	1	ADC reset channel 1
–	–	–	–	–	–	0	–	–
–	–	–	–	–	–	1	–	ADC reset channel 2
–	–	–	–	–	0	–	–	–
–	–	–	–	–	1	–	–	ADC reset channel 3
–	–	–	–	0	–	–	–	–
–	–	–	–	1	–	–	–	ADC reset channel 4
–	–	–	0	–	–	–	–	–
–	–	–	1	–	–	–	–	DAC reset channel 1
–	–	0	–	–	–	–	–	–
–	–	1	–	–	–	–	–	DAC reset channel 2
–	0	–	–	–	–	–	–	–
–	1	–	–	–	–	–	–	DAC reset channel 3
0	–	–	–	–	–	–	–	–
1	–	–	–	–	–	–	–	DAC reset channel 4

12.13 ADC Input Gain Control (0x1F)

Table 12-21. ADC Input Gain Control (0x1F)

Bit 7	Bit 6	Bit 5	Bit 4	Bit 3	Bit 2	Bit 1	Bit 0	DESCRIPTION
–	–	–	–	–	–	0	0	Channel 1Sinc input gain control = 0 dB
–	–	–	–	–	–	0	1	Channel 1Sinc input gain control = +30 dB
–	–	–	–	–	–	1	0	Channel 1Sinc input gain control = +600 dB
–	–	–	–	–	–	1	1	Channel 1Sinc input gain control = 0 dB
–	–	–	–	0	0	–	–	Channel 2Sinc input gain control = 0 dB
–	–	–	–	0	1	–	–	Channel 2Sinc input gain control = +30 dB
–	–	–	–	1	0	–	–	Channel 2Sinc input gain control = +60 dB
–	–	–	–	1	1	–	–	Channel 2Sinc input gain control = 0 dB
–	–	0	0	–	–	–	–	Channel 3Sinc input gain control = 0 dB
–	–	0	1	–	–	–	–	Channel 3Sinc input gain control = +30 dB
–	–	1	0	–	–	–	–	Channel 3Sinc input gain control = +60 dB
–	–	1	1	–	–	–	–	Channel 3Sinc input gain control = 0 dB
0	0	–	–	–	–	–	–	Channel 4Sinc input gain control = 0 dB
0	1	–	–	–	–	–	–	Channel 4Sinc input gain control = +30 dB
1	0	–	–	–	–	–	–	Channel 4Sinc input gain control = +60 dB
1	1	–	–	–	–	–	–	Channel 4Sinc input gain control = 0 dB

12.14 MCLK_OUT Divider (0x21 and 0x22)

Table 12-22. MCLK_OUT 2 (0x21)

Bit 7	Bit 6	Bit 5	Bit 4	Bit 3	Bit 2	Bit 1	Bit 0	DESCRIPTION
0	0	0	0	0	1	0	1	MCLK_OUT2 frequency is 6.144 MHz/(divider+1)

Table 12-23. MCLK_OUT 3 (0x22)

Bit 7	Bit 6	Bit 5	Bit 4	Bit 3	Bit 2	Bit 1	Bit 0	DESCRIPTION
0	0	0	0	0	0	0	0	MCLK_OUT3 frequency is 512 kHz/(divider+1)

12.15 Digital Cross Bar (0x30 to 0x3F)

Table 12-24. Digital Cross Bar (0x30 to 0x3F)

SUBADDRESS	REGISTER NAME	NO. OF BYTES	CONTENTS	INITIALIZATION VALUE
0x30	CH1 Input Mixer	32	Input cross bar mux	0x08 00 00 00 0x00 00 00 00 0x00 00 00 00 0x00 00 00 00 0x00 00 00 00 0x00 00 00 00 0x00 00 00 00 0x00 00 00 00
0x31	CH2 Input Mixer	32	Input cross bar mux	0x00 00 00 00 0x08 00 00 00 0x00 00 00 00 0x00 00 00 00 0x00 00 00 00 0x00 00 00 00 0x00 00 00 00
0x32	CH3 Input Mixer	32	Input cross bar mux	0x00 00 00 00 0x00 00 00 00 0x08 00 00 00 0x00 00 00 00 0x00 00 00 00 0x00 00 00 00 0x00 00 00 00
0x33	CH4 Input Mixer	32	Input cross bar mux	0x00 00 00 00 0x00 00 00 00 0x00 00 00 00 0x08 00 00 00 0x00 00 00 00 0x00 00 00 00 0x00 00 00 00
0x34	CH5 Input Mixer	32	Input cross bar mux	0x00 00 00 00 0x00 00 00 00 0x00 00 00 00 0x00 00 00 00 0x08 00 00 00 0x00 00 00 00 0x00 00 00 00

Table 12-24. Digital Cross Bar (0x30 to 0x3F) (continued)

SUBADDRESS	REGISTER NAME	NO. OF BYTES	CONTENTS	INITIALIZATION VALUE
0x35	CH6 Input Mixer	32	Input cross bar mux	0x00 00 00 00 0x00 00 00 00 0x00 00 00 00 0x00 00 00 00 0x00 00 00 00 0x08 00 00 00 0x00 00 00 00 0x00 00 00 00
0x36	CH7 Input Mixer	32	Input cross bar mux	0x00 00 00 00 0x00 00 00 00 0x00 00 00 00 0x00 00 00 00 0x00 00 00 00 0x00 00 00 00 0x08 00 00 00 0x00 00 00 00
0x37	CH8 Input Mixer	32	Input cross bar mux	0x00 00 00 00 0x00 00 00 00 0x00 00 00 00 0x00 00 00 00 0x00 00 00 00 0x00 00 00 00 0x08 00 00 00
0x38	CH1 Output Mixer	32	Input cross bar mux	0x08 00 00 00 0x00 00 00 00 0x00 00 00 00 0x00 00 00 00 0x00 00 00 00 0x00 00 00 00 0x00 00 00 00 0x00 00 00 00
0x39	CH2 Output Mixer	32	Input cross bar mux	0x00 00 00 00 0x08 00 00 00 0x00 00 00 00 0x00 00 00 00 0x00 00 00 00 0x00 00 00 00 0x00 00 00 00 0x00 00 00 00
0x3A	CH3 Output Mixer	32	Input cross bar mux	0x00 00 00 00 0x00 00 00 00 0x08 00 00 00 0x00 00 00 00 0x00 00 00 00 0x00 00 00 00 0x00 00 00 00 0x00 00 00 00
0x3B	CH4 Output Mixer	32	Input cross bar mux	0x00 00 00 00 0x00 00 00 00 0x00 00 00 00 0x08 00 00 00 0x00 00 00 00 0x00 00 00 00 0x00 00 00 00 0x00 00 00 00
0x3C	CH5 Output Mixer	32	Input cross bar mux	0x00 00 00 00 0x00 00 00 00 0x00 00 00 00 0x00 00 00 00 0x08 00 00 00 0x00 00 00 00 0x00 00 00 00 0x00 00 00 00

Table 12-24. Digital Cross Bar (0x30 to 0x3F) (continued)

SUBADDRESS	REGISTER NAME	NO. OF BYTES	CONTENTS	INITIALIZATION VALUE
0x3D	CH6 Output Mixer	32	Input cross bar mux	0x00 00 00 00 0x00 00 00 00 0x00 00 00 00 0x00 00 00 00 0x00 00 00 00 0x08 00 00 00 0x00 00 00 00 0x00 00 00 00
0x3E	CH7 Output Mixer	32	Input cross bar mux	0x00 00 00 00 0x00 00 00 00 0x00 00 00 00 0x00 00 00 00 0x00 00 00 00 0x00 00 00 00 0x08 00 00 00 0x00 00 00 00
0x3F	CH8 Output Mixer	32	Input cross bar mux	0x00 00 00 00 0x00 00 00 00 0x00 00 00 00 0x00 00 00 00 0x00 00 00 00 0x00 00 00 00 0x08 00 00 00

12.16 Extended Special Function Registers (ESFR) Map

ESFR provide communication between the embedded MCU and the DSP core. The following table outlines the functionality of the ESFRs. These registers should only be accessed if the user intend to write custom TAS3204 MCU Program Code as changing some of these registers may result in undesired or unspecified operation of the TAS3204 DAP.

Table 12-25. Extended Special Function Registers (ESFR)

ESFR	MAPPED_TO	NO. OF BITS	DIRECTION	CONNECTING BLOCK	REGISTER TYPE	DESCRIPTION
	di_o	8	OUT	I ² C	8-bit asynchronous rstz positive edge triggered Reset low	Data to be transferred from MCU to I ² C
85	da_i	8	IN	I ² C	NO REG - direct input	Data to be transferred from I ² C to MCU during slave write in I ² C slave-write mode if the MCU controls I ² C interface
86	sub_addr_i	8	IN	I ² C	NO REG – direct input	Indicates the type of information being relayed to the MCU. This affects how the MCU changes the data that follows the subaddress.
91	data_out1_i	8	IN	I ² C	NO REG – direct input	These registers are used to deliver data from the I ² C block to the MCU.
92	data_out2_i	8	IN	I ² C	NO REG – direct input	
93	data_out3_i	8	IN	I ² C	NO REG – direct input	
94	data_out4_i	8	IN	I ² C	NO REG – direct input	
95	A_o	3	OUT	I ² C	8-bit asynchronous rstz positive edge triggered Reset Low	Address of I ² C internal registers. See Mentor I ² C product specification.
96	i2s_word_byte_t	8	OUT	SAP	8-bit asynchronous rstz positive edge triggered Reset Low	Bit definition follows functional spec definition for specification SAP WORD byte
97	i2s_mode_byte_t	8	OUT	SAP	8-bit asynchronous rstz positive edge triggered Reset Low	Bit definition follows functional spec definition for specification SAP mode byte
A1	MLRCLK_t	5	OUT	CLOCK	5-bit asynchronous rstz positive edge triggered Reset Low	Bit definition follows functional spec definition for specification MLRCLK field

Table 12-25. Extended Special Function Registers (ESFR) (continued)

ESFR	MAPPED_TO	NO. OF BITS	DIRECTION	CONNECTING BLOCK	REGISTER TYPE	DESCRIPTION
A2	SCLK_t	8	OUT	CLOCK	8-bit asynchronous rstz positive edge triggered Reset Low	Bit definition follows functional spec definition for specification SCLK field
A3	addr_sel_t	4	OUT	DELAY_MEM	4-bit asynchronous rstz positive edge triggered Reset Low	Delay memory select lines
A4	addr_t	8	OUT	DELAY_MEM	8-bit asynchronous rstz positive edge triggered Reset Low	Delay memory address bus
A5	addr_t	5	OUT	DELAY_MEM	5-bit asynchronous rstz positive edge triggered Reset Low	Delay memory address bus high bits
A6	vol_mode_i_t	2	OUT	VOLUME	2-bit asynchronous rstz positive edge triggered Reset Low	Specify slew rate 0, 1, 2 (2048, 4096, 8192)
A7	volume_index_i_t	3	OUT	VOLUME	3-bit asynchronous rstz positive edge triggered Reset Low	Host control channel specification
A9		8	OUT	VOLUME	8-bit asynchronous rstz positive edge triggered Reset Low	Volume coefficient
AA	vol_data_i_t	8	OUT	VOLUME	8-bit asynchronous rstz positive edge triggered Reset Low	
AB	vol_data_i_t	8	OUT	VOLUME	8-bit asynchronous rstz positive edge triggered Reset Low	
AC	vol_data_i_t	4	OUT	VOLUME	4-bit asynchronous rstz positive edge triggered Reset Low	
AD	To_MCU_i[7:0]	8	IN	DSP	NO REG – direct input	Data bus from DSP to the MCU
AE	To_MCU_i[15:8]	8	IN	DSP	NO REG – direct input	
AF	To_MCU_i[23:16]	8	IN	DSP	NO REG – direct input	
B1	To_MCU_i[31:24]	8	IN	DSP	NO REG – direct input	
B2	To_MCU_i[39:32]	8	IN	DSP	NO REG – direct input	
Bit 6	To_MCU_i[47:40]	8	IN	DSP	NO REG – direct input	
Bit 7	To_MCU_i[53:48]	8	IN	DSP	NO REG – direct input	
B3	Data_to_DSP_o[7:0]	8	OUT	DSP	8-bit asynchronous rstz positive edge triggered Reset Low	Data bus from MCU to the DSP
B4	Data_to_DSP_o[15:0]	8	OUT	DSP	8-bit asynchronous rstz positive edge triggered	
B5	Data_to_DSP_o[23:16]	8	OUT	DSP	8-bit asynchronous rstz positive edge triggered	
B6	Data_to_DSP_o[31:24]	8	OUT	DSP	8-bit asynchronous rstz positive edge triggered Reset Low	
B7	Data_to_DSP_o[39:32]	8	OUT	DSP	8-bit asynchronous rstz positive edge triggered Reset Low	
B9	Data_to_DSP_o[47:40]	8	OUT	DSP	8-bit asynchronous rstz positive edge triggered Reset Low	
BA	Data_to_DSP_o[53:48]	8	OUT	DSP	8-bit asynchronous rstz positive edge triggered Reset Low	
BB	MCU_addr_o[7:0]	8	OUT	DSP	8-bit asynchronous rstz positive edge triggered Reset Low	MCU uses these 16 bits to set DSP RAM and MCU I addresses
BC	MCU_addr_o[13:8]	8	OUT	DSP	8-bit asynchronous rstz positive edge triggered Reset Low	MCU uses these 16 bits to set DSP RAM and MCU I addresses Bit 10 of the address selects between audio DSP coefficient and audio DSP data memory

Table 12-25. Extended Special Function Registers (ESFR) (continued)

ESFR	MAPPED_TO	NO. OF BITS	DIRECTION	CONNECTING BLOCK	REGISTER TYPE	DESCRIPTION
BD	Mode0_o	1	OUT	DSP	1-bit asynchronous rstz positive edge triggered Reset low	Miscellaneous signal for MCU-DSP communication. This is not a bit-addressable register, but contains bit data. The firmware must read in the data, mask the change, and write it back out.
BE	Mode3_o	1	OUT	DSP	1-bit asynchronous rstz positive edge triggered, Reset low	
BF	Mode4_o	1	OUT	DSP	1-bit asynchronous rstz positive edge triggered Reset low	
C1	C1 Mode5_o	1	OUT	DSP	1-bit asynchronous rstz positive edge triggered Reset low	Miscellaneous signal for MCU-DSP communication. This is not a bit-addressable register, but contains bit data. The firmware must read in the data, mask the change, and write it back out.
C2	Mode6_o	1	OUT	DSP	1-bit asynchronous rstz positive edge triggered Reset low	
C3	Mode7_o	1	OUT	DSP	1-bit asynchronous rstz positive edge triggered Reset low	
C4	Mode8_o	1	OUT	DSP	1-bit asynchronous rstz positive edge triggered Reset low	
C5	GPIO_IN_t	1	IN	DSP	1-bit asynchronous rstz positive edge triggered Reset Low	Registered input GPIO sense line
C6	gpio_enz_t	1	OUT	GPIO	4-bit asynchronous rstz positive edge triggered Reset Low	GPIO bidirect configuration—low → output, high → input
C7	gpio_out_t	1	OUT	GPIO	1-bit asynchronous rstz positive edge triggered Reset Low	Drive value on GPIO line when configured as output
C9	cs1	1	IN	CHIP_SEL	1-bit asynchronous rstz positive edge triggered Reset Low	Reset-low sense lines for chip-select input/output
CA	tb_loop_count_t	8	OUT	TONE	8-bit asynchronous rstz positive edge triggered Reset Low	Tone slew rate counter configuration
CB	dlymemif_out	8	IN	DLY_MEM	NO REG – direct input	Low-byte delay interface data port
CC	dlymemif_out	8	IN	DLY_MEM	NO REG – direct input	High-byte delay interface data port
CD	dlymemif_out	8	IN	DLY_MEM	NO REG – direct input	High-byte delay interface data port
CE	cntrl1_treb_active_t	1	OUT	TONE	1-bit asynchronous rstz positive edge triggered Reset low	Schedule tone coefficient calculations in the audio DSP
CF	cntrl2_treb_active_t	1	OUT	TONE	1-bit asynchronous rstz positive edge triggered Reset low	
Bit 0	cntrl3_treb_active_t	1	OUT	TONE	1-bit asynchronous rstz positive edge triggered Reset low	
Bit 1	cntrl4_treb_active_t	1	OUT	TONE	1-bit asynchronous rstz positive edge triggered Reset low	
Bit 2	cntrl1_bass_active_t	1	OUT	TONE	1-bit asynchronous rstz positive edge triggered Reset low	
Bit 3	cntrl2_bass_active_t	1	OUT	TONE	1-bit asynchronous rstz positive edge triggered Reset low	Schedule tone coefficient calculations in the audio DSP
Bit 4	cntrl3_bass_active_t	1	OUT	TONE	1-bit asynchronous rstz positive edge triggered Reset low	
Bit 5	cntrl4_bass_active_t	1	OUT	TONE	1-bit asynchronous rstz positive edge triggered Reset low	Schedule tone coefficient calculations in the audio DSP

Table 12-25. Extended Special Function Registers (ESFR) (continued)

ESFR	MAPPED_TO	NO. OF BITS	DIRECTION	CONNECTING BLOCK	REGISTER TYPE	DESCRIPTION
C0(0)	I2c_irg_o	1	OUT	I ² C	1-bit asynchronous rstz positive edge triggered ONE SHOT (PULSE) Reset low	PULSE REGISTER Slave read: set high when MCU recognizes that the SLAVE_READ bit on the I ² C has been set high. Slave write: if the RCVD_DATA_STAT bit is set high by the I ² C, MCU sets IRG high in response.
C0(1)	I2c_mcu_o	1	OUT	I ² C	1-bit asynchronous rstz positive edge triggered <i>RESET HI</i>	PULSE REGISTER I2C_MCU is set to 1 MCU assumes control over the I ² C interface. If it is set to 0, the I ² C block has control. If the MCU reads a 1 on slave_read, it sends an ACK to the I ² C and sets I2C_MCU high.
C0(2)	update_volume_t	1	OUT	VOLUME	1-bit asynchronous rstz positive edge triggered Reset low	Signoff assertion that volume coefficients to volume block are updated and execution is commanded
C0(3)	clr_dly_RAM_t	1	OUT	DLY_MEM	1-bit asynchronous rstz positive edge triggered Reset low	Used during initialization to inspire self-clearing logic activation to the delay RAM
C0(4)	wr_t	1	OUT	I ² C	1-bit asynchronous rstz positive edge triggered ONE SHOT (PULSE)	PULSE REGISTER I ² C write pulse for slave transmit and master transmit
C0(5)	I2c_sel_o	1	OUT	I ² C	1-bit asynchronous rstz positive edge triggered	The I ² C has two registers to which the MCU can write. This signal selects one of them.
C0(6)	MCU_RAM_we_req_o	1	OUT	DSP	1-bit asynchronous rstz positive edge triggered ONE SHOT (PULSE)	PULSE REGISTER When DSP_HOST = 1, the MCU has direct control of the RAMs and pulses this signal to write to them.
C0(7)	MCU_rd_req_o	1	OUT	DSP	1-bit asynchronous rstz positive edge triggered ONE SHOT (PULSE)	When DSP_HOST is high and the MCU has complete control of the DSP RAMs, this bit is N/A. When DSP_HOST is low, the MCU uses this bit to submit a read request to the DSP.
C8(0)	power_down_in	1	IN	CNTL	NO REG – direct input	Power-down pin sense
C8(2)	vol_busy_o	1	IN	VOL	1-bit asynchronous rstz positive edge triggered Reset High	Volume busy flag
C8(3)	mem_bist_i	1	IN	membist	Direct input	Indicates chip is in firmware BIST mode
C8(4)	intr	1	IN	CNTL	Direct input	Indicates status warp IFLAG
C8(5)	MCU_ack_l	1	IN	DSP	1-bit asynchronous rstz positive edge triggered Reset low	DSP sets this bit to notify MCU it has captured data
C8(6)	clearing_dly_RAM_t	1	IN	DSP	1-bit asynchronous rstz positive edge triggered Reset low	Busy flag from Delay RAM Init clear process
C8(7)	dsp_rom_bist_l	1	IN	DSP	NO REG – direct input	Set HIGH to signal that DSP ROM BIST completed successfully
D8(0)	power_down_o	1	OUT	Multiple blks	1-bit asynchronous rstz positive edge triggered Reset low	Set HIGH by the MCU. (Need more info)
D8(1)	watchdog_clr_t	1	OUT	CNTL	1-bit asynchronous rstz positive edge triggered Reset low	Strobe to the watchdog timer logic
D8(2)	slave_mode_t	1	OUT	DLY_MEM	1-bit asynchronous rstz positive edge triggered Reset low	Asserted to provide direct delay memory access to the host (MCU)
D8(3)	addr_wr_t	1	OUT	DLY_MEM	1-bit asynchronous rstz positive edge triggered Reset low	Write assertion to delay memory during host control configuration
D8(4)	MCU_wr_en_i_t	1	OUT	DSP	1-bit asynchronous rstz positive edge triggered Reset low	Write enable signal to the audio DSP coefficients and DATA RAMs
D8(5)	host_DSP_o	1	OUT	DSP	1-bit asynchronous rstz positive edge triggered Reset high	Sets the DSP in host mode. MCU is in control

Table 12-25. Extended Special Function Registers (ESFR) (continued)

ESFR	MAPPED_TO	NO. OF BITS	DIRECTION	CONNECTING BLOCK	REGISTER TYPE	DESCRIPTION
D8(6)	bass_data_ready_o	1	OUT	T/B	1-bit asynchronous rstz positive edge triggered Reset low	MCU notifies T/B block that bass data has been processed and is ready.
D8(7)	treble_data_ready_o	1	OUT	T/B	1-bit asynchronous rstz positive edge triggered Reset low	MCU notifies T/B block that treble data has been processed and is ready.
D9	MEM_SEL	2	OUT	MCU DAP	2-bit asynchronous rstz positive edge triggered Reset low	00 Audio DSP coefficient/data (Depending on address bit 10)
						01 Audio DSP instruction
						10 MCU instruction
						11 Reserved
FC	i2c_ms_ctl	1	OUT	I ² C	1-bit asynchronous rstz positive edge triggered Reset low	Select Master or Slave mode by switching mux
FD	pc_source	1	OUT		1-bit asynchronous rstz positive edge triggered Reset low	Changes source from MCU program ROM to MCU program RAM
FE	sap_en_t	1	OUT	SAP	1-bit asynchronous rstz positive edge triggered Reset Low	Expected to toggle high, then low, to inspire a recent SAP change to activate.

13 Application Information

13.1 Schematics

Figure 13-1 shows a typical TAS3204 application. In this application the following conditions apply:

- TAS3204 is in clock-master mode. The TAS3204 generates MCLK_OUT1, SCLK_OUT, and LRCLOCK_OUT.
- XTAL_IN = 24.576 MHz
- I²C register 0x00 contains the default settings, which means:
 - Audio data word size is 24-bit input and 24-bit output.
 - Serial data format is 2-channel, I²S for input and output.
 - I²C data transfer is approximately 400 kbps for both master and slave I²C interfaces.
 - Sample frequency (f_s) is 48 kHz, which means that $f_{LRCLK} = 48$ kHz and $f_{SCLKIN} = 3.072$ MHz.
- Application code and data are loaded from an external EEPROM using the master I²C interface.
- Application commands come from the system MCU to the TAS3204 using the slave I²C interface.

Good design practice requires isolation between the digital and analog power as shown. Power supply capacitors of 10 μ F and 0.1 μ F should be placed near the power supply pins AVDD (AVSS) and DVDD (DVSS).

The TAS3204 reset needs external glitch protection. Also, reset going HIGH should be delayed until TAS3204 internal power is good (~ 200 μ s after power up). This is provided by the 1-k Ω resistor, 1- μ F capacitor, and diode placed near the RESET pin.

It is recommended that a 4.7- μ F capacitor (fast ceramic type) be placed near pin 28 (VR_DIG). This pin must not be used to source external components.

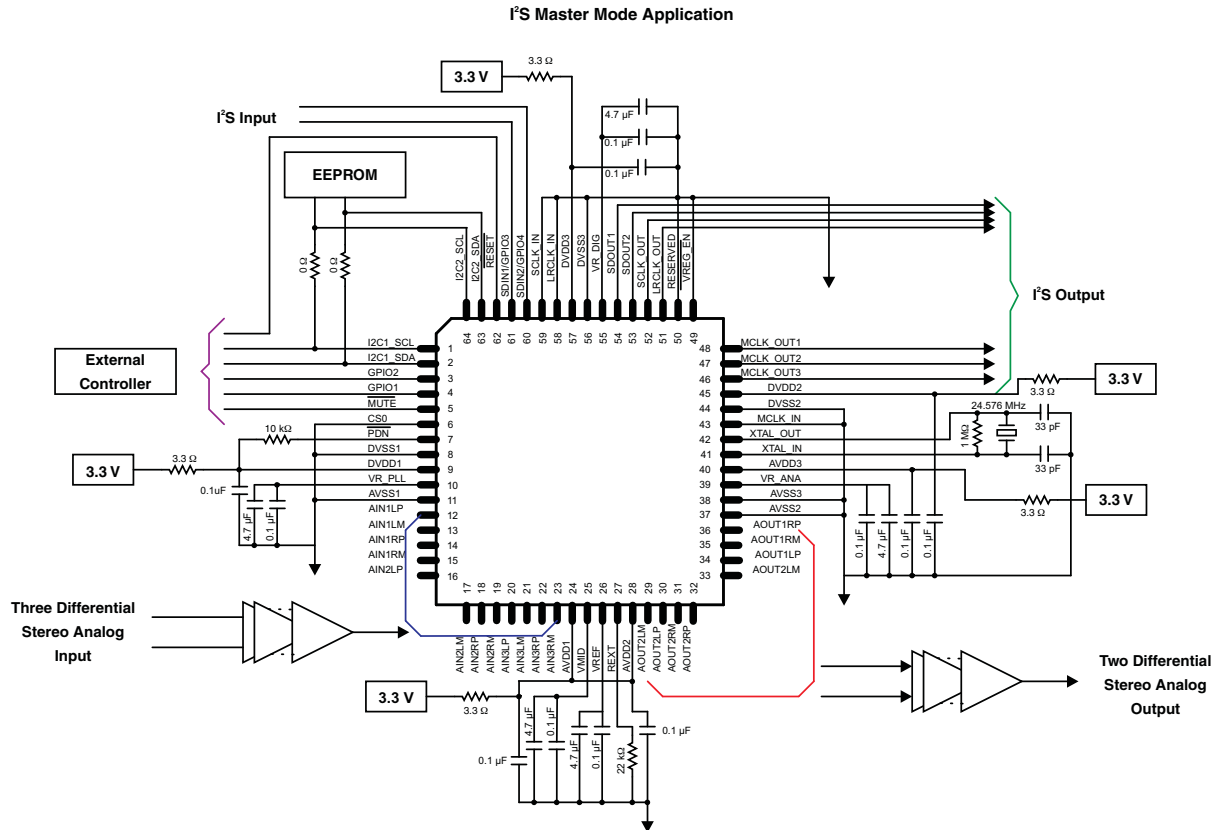

A. Capacitors should be placed as close as possible to the power supply pins.

Figure 13-1. Typical Application Diagram

13.2 Recommended Oscillator Circuit

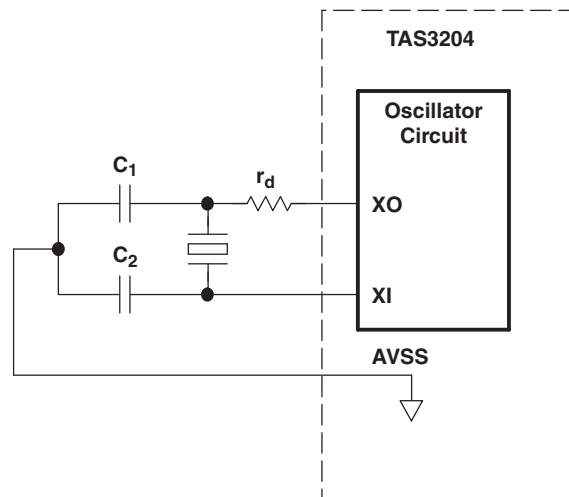

- Crystal type = parallel-mode, fundamental-mode crystal
- r_d = drive-level control resistor – vendor specified
- C_L = Crystal load capacitance (capacitance of circuitry between the two terminals of the crystal)
- $C_L = (C_1 \times C_2) / (C_1 + C_2) + C_S$ (where C_S = board stray capacitance, ~2 pF)

PACKAGING INFORMATION

Orderable Device	Status (1)	Package Type	Package Drawing	Pins	Package Qty	Eco Plan (2)	Lead/Ball Finish	MSL Peak Temp (3)	Op Temp (°C)	Top-Side Markings (4)	Samples
TAS3204PAG	NRND	TQFP	PAG	64	160	Green (RoHS & no Sb/Br)	CU NIPDAU	Level-4-260C-72 HR	0 to 70	TAS3204PAG	
TAS3204PAGR	NRND	TQFP	PAG	64	1500	Green (RoHS & no Sb/Br)	CU NIPDAU	Level-4-260C-72 HR	0 to 70	TAS3204PAG	

(1) The marketing status values are defined as follows:

ACTIVE: Product device recommended for new designs.

LIFEBUY: TI has announced that the device will be discontinued, and a lifetime-buy period is in effect.

NRND: Not recommended for new designs. Device is in production to support existing customers, but TI does not recommend using this part in a new design.

PREVIEW: Device has been announced but is not in production. Samples may or may not be available.

OBSOLETE: TI has discontinued the production of the device.

(2) Eco Plan - The planned eco-friendly classification: Pb-Free (RoHS), Pb-Free (RoHS Exempt), or Green (RoHS & no Sb/Br) - please check <http://www.ti.com/productcontent> for the latest availability information and additional product content details.

TBD: The Pb-Free/Green conversion plan has not been defined.

Pb-Free (RoHS): TI's terms "Lead-Free" or "Pb-Free" mean semiconductor products that are compatible with the current RoHS requirements for all 6 substances, including the requirement that lead not exceed 0.1% by weight in homogeneous materials. Where designed to be soldered at high temperatures, TI Pb-Free products are suitable for use in specified lead-free processes.

Pb-Free (RoHS Exempt): This component has a RoHS exemption for either 1) lead-based flip-chip solder bumps used between the die and package, or 2) lead-based die adhesive used between the die and leadframe. The component is otherwise considered Pb-Free (RoHS compatible) as defined above.

Green (RoHS & no Sb/Br): TI defines "Green" to mean Pb-Free (RoHS compatible), and free of Bromine (Br) and Antimony (Sb) based flame retardants (Br or Sb do not exceed 0.1% by weight in homogeneous material)

(3) MSL, Peak Temp. -- The Moisture Sensitivity Level rating according to the JEDEC industry standard classifications, and peak solder temperature.

(4) Multiple Top-Side Markings will be inside parentheses. Only one Top-Side Marking contained in parentheses and separated by a "~" will appear on a device. If a line is indented then it is a continuation of the previous line and the two combined represent the entire Top-Side Marking for that device.

Important Information and Disclaimer: The information provided on this page represents TI's knowledge and belief as of the date that it is provided. TI bases its knowledge and belief on information provided by third parties, and makes no representation or warranty as to the accuracy of such information. Efforts are underway to better integrate information from third parties. TI has taken and continues to take reasonable steps to provide representative and accurate information but may not have conducted destructive testing or chemical analysis on incoming materials and chemicals. TI and TI suppliers consider certain information to be proprietary, and thus CAS numbers and other limited information may not be available for release.

In no event shall TI's liability arising out of such information exceed the total purchase price of the TI part(s) at issue in this document sold by TI to Customer on an annual basis.

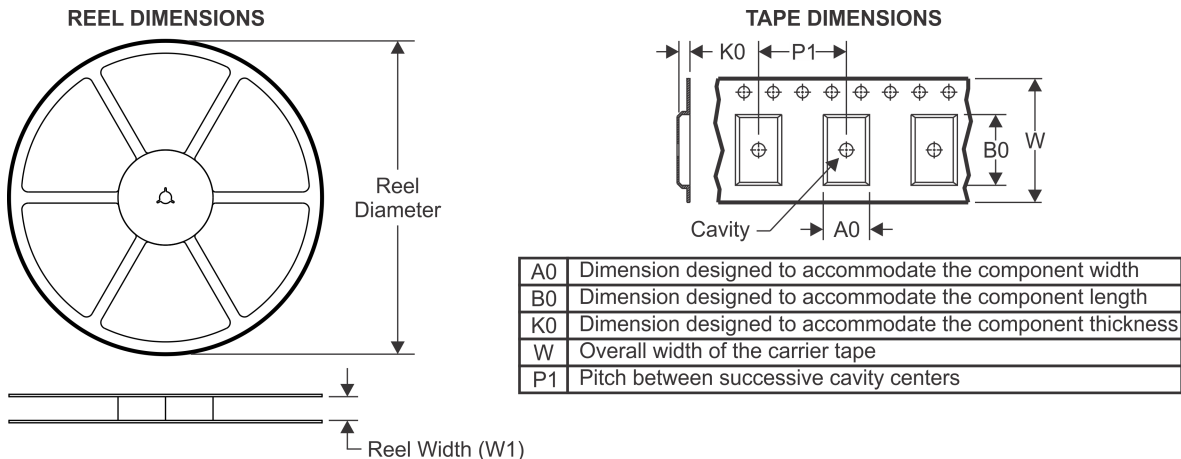
TAPE AND REEL INFORMATION

QUADRANT ASSIGNMENTS FOR PIN 1 ORIENTATION IN TAPE

*All dimensions are nominal

Device	Package Type	Package Drawing	Pins	SPQ	Reel Diameter (mm)	Reel Width W1 (mm)	A0 (mm)	B0 (mm)	K0 (mm)	P1 (mm)	W (mm)	Pin1 Quadrant
TAS3204PAGR	TQFP	PAG	64	1500	330.0	24.4	13.0	13.0	1.5	16.0	24.0	Q2

TAPE AND REEL BOX DIMENSIONS

*All dimensions are nominal

Device	Package Type	Package Drawing	Pins	SPQ	Length (mm)	Width (mm)	Height (mm)
TAS3204PAGR	TQFP	PAG	64	1500	367.0	367.0	45.0

PAG (S-PQFP-G64)

PLASTIC QUAD FLATPACK



- NOTES: A. All linear dimensions are in millimeters.
 B. This drawing is subject to change without notice.
 C. Falls within JEDEC MS-026



- NOTES:
- A. All linear dimensions are in millimeters.
 - B. This drawing is subject to change without notice.
 - C. Laser cutting apertures with trapezoidal walls and also rounding corners will offer better paste release. Customers should contact their board assembly site for stencil design recommendations. Example stencil design based on a 50% volumetric metal load solder paste. Refer to IPC-7525 for other stencil recommendations.
 - D. Customers should contact their board fabrication site for solder mask tolerances between and around signal pads.



- NOTES:
- A. All linear dimensions are in millimeters.
 - B. This drawing is subject to change without notice.
 - C. Laser cutting apertures with trapezoidal walls and also rounding corners will offer better paste release. Customers should contact their board assembly site for stencil design recommendations. Example stencil design based on a 50% volumetric metal load solder paste. Refer to IPC-7525 for other stencil recommendations.
 - D. Customers should contact their board fabrication site for solder mask tolerances between and around signal pads.

IMPORTANT NOTICE

Texas Instruments Incorporated (TI) reserves the right to make corrections, enhancements, improvements and other changes to its semiconductor products and services per JESD46, latest issue, and to discontinue any product or service per JESD48, latest issue. Buyers should obtain the latest relevant information before placing orders and should verify that such information is current and complete.

TI's published terms of sale for semiconductor products (<http://www.ti.com/sc/docs/stdterms.htm>) apply to the sale of packaged integrated circuit products that TI has qualified and released to market. Additional terms may apply to the use or sale of other types of TI products and services.

Reproduction of significant portions of TI information in TI data sheets is permissible only if reproduction is without alteration and is accompanied by all associated warranties, conditions, limitations, and notices. TI is not responsible or liable for such reproduced documentation. Information of third parties may be subject to additional restrictions. Resale of TI products or services with statements different from or beyond the parameters stated by TI for that product or service voids all express and any implied warranties for the associated TI product or service and is an unfair and deceptive business practice. TI is not responsible or liable for any such statements.

Buyers and others who are developing systems that incorporate TI products (collectively, "Designers") understand and agree that Designers remain responsible for using their independent analysis, evaluation and judgment in designing their applications and that Designers have full and exclusive responsibility to assure the safety of Designers' applications and compliance of their applications (and of all TI products used in or for Designers' applications) with all applicable regulations, laws and other applicable requirements. Designer represents that, with respect to their applications, Designer has all the necessary expertise to create and implement safeguards that (1) anticipate dangerous consequences of failures, (2) monitor failures and their consequences, and (3) lessen the likelihood of failures that might cause harm and take appropriate actions. Designer agrees that prior to using or distributing any applications that include TI products, Designer will thoroughly test such applications and the functionality of such TI products as used in such applications.

TI's provision of technical, application or other design advice, quality characterization, reliability data or other services or information, including, but not limited to, reference designs and materials relating to evaluation modules, (collectively, "TI Resources") are intended to assist designers who are developing applications that incorporate TI products; by downloading, accessing or using TI Resources in any way, Designer (individually or, if Designer is acting on behalf of a company, Designer's company) agrees to use any particular TI Resource solely for this purpose and subject to the terms of this Notice.

TI's provision of TI Resources does not expand or otherwise alter TI's applicable published warranties or warranty disclaimers for TI products, and no additional obligations or liabilities arise from TI providing such TI Resources. TI reserves the right to make corrections, enhancements, improvements and other changes to its TI Resources. TI has not conducted any testing other than that specifically described in the published documentation for a particular TI Resource.

Designer is authorized to use, copy and modify any individual TI Resource only in connection with the development of applications that include the TI product(s) identified in such TI Resource. NO OTHER LICENSE, EXPRESS OR IMPLIED, BY ESTOPPEL OR OTHERWISE TO ANY OTHER TI INTELLECTUAL PROPERTY RIGHT, AND NO LICENSE TO ANY TECHNOLOGY OR INTELLECTUAL PROPERTY RIGHT OF TI OR ANY THIRD PARTY IS GRANTED HEREIN, including but not limited to any patent right, copyright, mask work right, or other intellectual property right relating to any combination, machine, or process in which TI products or services are used. Information regarding or referencing third-party products or services does not constitute a license to use such products or services, or a warranty or endorsement thereof. Use of TI Resources may require a license from a third party under the patents or other intellectual property of the third party, or a license from TI under the patents or other intellectual property of TI.

TI RESOURCES ARE PROVIDED "AS IS" AND WITH ALL FAULTS. TI DISCLAIMS ALL OTHER WARRANTIES OR REPRESENTATIONS, EXPRESS OR IMPLIED, REGARDING RESOURCES OR USE THEREOF, INCLUDING BUT NOT LIMITED TO ACCURACY OR COMPLETENESS, TITLE, ANY EPIDEMIC FAILURE WARRANTY AND ANY IMPLIED WARRANTIES OF MERCHANTABILITY, FITNESS FOR A PARTICULAR PURPOSE, AND NON-INFRINGEMENT OF ANY THIRD PARTY INTELLECTUAL PROPERTY RIGHTS. TI SHALL NOT BE LIABLE FOR AND SHALL NOT DEFEND OR INDEMNIFY DESIGNER AGAINST ANY CLAIM, INCLUDING BUT NOT LIMITED TO ANY INFRINGEMENT CLAIM THAT RELATES TO OR IS BASED ON ANY COMBINATION OF PRODUCTS EVEN IF DESCRIBED IN TI RESOURCES OR OTHERWISE. IN NO EVENT SHALL TI BE LIABLE FOR ANY ACTUAL, DIRECT, SPECIAL, COLLATERAL, INDIRECT, PUNITIVE, INCIDENTAL, CONSEQUENTIAL OR EXEMPLARY DAMAGES IN CONNECTION WITH OR ARISING OUT OF TI RESOURCES OR USE THEREOF, AND REGARDLESS OF WHETHER TI HAS BEEN ADVISED OF THE POSSIBILITY OF SUCH DAMAGES.

Unless TI has explicitly designated an individual product as meeting the requirements of a particular industry standard (e.g., ISO/TS 16949 and ISO 26262), TI is not responsible for any failure to meet such industry standard requirements.

Where TI specifically promotes products as facilitating functional safety or as compliant with industry functional safety standards, such products are intended to help enable customers to design and create their own applications that meet applicable functional safety standards and requirements. Using products in an application does not by itself establish any safety features in the application. Designers must ensure compliance with safety-related requirements and standards applicable to their applications. Designer may not use any TI products in life-critical medical equipment unless authorized officers of the parties have executed a special contract specifically governing such use. Life-critical medical equipment is medical equipment where failure of such equipment would cause serious bodily injury or death (e.g., life support, pacemakers, defibrillators, heart pumps, neurostimulators, and implantables). Such equipment includes, without limitation, all medical devices identified by the U.S. Food and Drug Administration as Class III devices and equivalent classifications outside the U.S.

TI may expressly designate certain products as completing a particular qualification (e.g., Q100, Military Grade, or Enhanced Product). Designers agree that it has the necessary expertise to select the product with the appropriate qualification designation for their applications and that proper product selection is at Designers' own risk. Designers are solely responsible for compliance with all legal and regulatory requirements in connection with such selection.

Designer will fully indemnify TI and its representatives against any damages, costs, losses, and/or liabilities arising out of Designer's non-compliance with the terms and provisions of this Notice.