

TCA9546A Low Voltage 4-Channel I²C and SMBus Switch with Reset Function

1 Features

- 1-of-4 Bidirectional Translating Switches
- I²C Bus and SMBus Compatible
- Active-Low Reset Input
- Three Address Pins, Allowing up to Eight TCA9546A Devices on the I²C Bus
- Channel Selection Via I²C Bus, in Any Combination
- Power-up With All Switch Channels Deselected
- Low R_{ON} Switches
- Allows Voltage-Level Translation Between 1.8-V, 2.5-V, 3.3-V, and 5-V Buses
- No Glitch on Power-up
- Supports Hot Insertion
- Low Standby Current
- Operating Power-Supply Voltage Range of 1.65 V to 5.5 V
- 5.5 V Tolerant Inputs
- 0 to 400-kHz Clock Frequency
- Latch-Up Performance Exceeds 100 mA Per JESD 78
- ESD Protection Exceeds JESD 22
 - 4000-V Human-Body Model (A114-A)
 - 1500-V Charged-Device Model (C101)

2 Applications

- Servers
- Routers (Telecom Switching Equipment)
- Factory Automation
- Products With I²C Slave Address Conflicts (e.g. Multiple, Identical Temp Sensors)

3 Description

The TCA9546A is a quad bidirectional translating switch controlled via the I²C bus. The SCL/SDA upstream pair fans out to four downstream pairs, or channels. Any individual SC_n/SD_n channel or combination of channels can be selected, determined by the contents of the programmable control register.

An active-low reset ($\overline{\text{RESET}}$) input allows the TCA9546A to recover from a situation in which one of the downstream I²C buses is stuck in a low state. Pulling $\overline{\text{RESET}}$ low resets the I²C state machine and causes all the channels to be deselected, as does the internal power-on reset function.

The pass gates of the switches are constructed such that the VCC pin can be used to limit the maximum high voltage, which will be passed by the TCA9546A. This allows the use of different bus voltages on each pair, so that 1.8-V, 2.5-V, or 3.3-V parts can communicate with 5-V parts without any additional protection. External pull-up resistors pull the bus up to the desired voltage level for each channel. All I/O pins are 5.5-V tolerant.

Device Information⁽¹⁾

DEVICE NAME	PACKAGE	BODY SIZE (NOM)
TCA9546A	TSSOP (16)	5.00 mm x 4.40 mm
	SOIC (16)	9.90 mm x 3.91 mm

(1) For all available packages, see the orderable addendum at the end of the datasheet.

4 Simplified Application Diagram

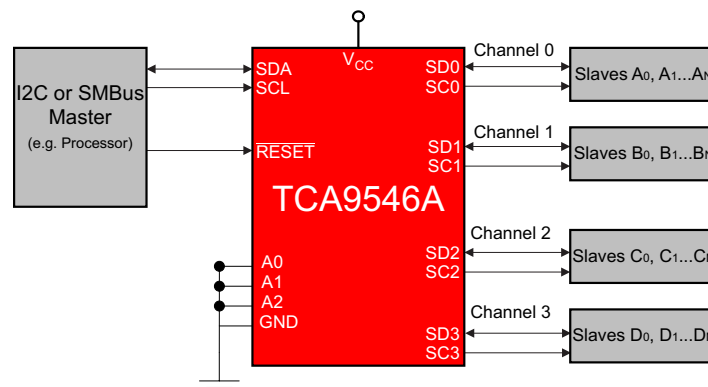

Table of Contents

1 Features	1	9.2 Functional Block Diagram	10
2 Applications	1	9.3 Feature Description	11
3 Description	1	9.4 Device Functional Modes	11
4 Simplified Application Diagram	1	9.5 Programming	11
5 Revision History	2	9.6 Control Register	14
6 Pin Configuration and Functions	3	10 Application and Implementation	16
7 Specifications	4	10.1 Application Information	16
7.1 Absolute Maximum Ratings	4	10.2 Typical Application	16
7.2 ESD Ratings	4	11 Power Supply Recommendations	19
7.3 Recommended Operating Conditions	4	11.1 Power-On Reset Requirements	19
7.4 Thermal Information	4	12 Layout	21
7.5 Electrical Characteristics	5	12.1 Layout Guidelines	21
7.6 I ² C Interface Timing Requirements	6	12.2 Layout Example	21
7.7 Switching Characteristics	6	13 Device and Documentation Support	22
7.8 Interrupt and Reset Timing Requirements	7	13.1 Trademarks	22
7.9 Typical Characteristics	7	13.2 Electrostatic Discharge Caution	22
8 Parameter Measurement Information	8	13.3 Glossary	22
9 Detailed Description	10	14 Mechanical, Packaging, and Orderable Information	22
9.1 Overview	10		

5 Revision History

Changes from Original (April 2014) to Revision A	Page
• Added D package to the datasheet.	1
• Changed Handling Ratings table to ESD Ratings.	4
• Added D package to the Thermal Information table.	4

6 Pin Configuration and Functions

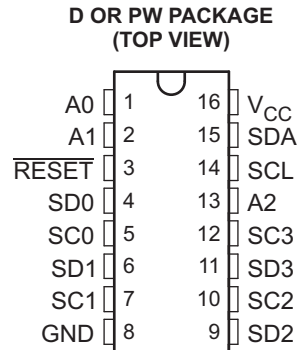

Pin Functions

PIN		DESCRIPTION
NAME	NO. D, PW	
A0	1	Address input 0. Connect directly to V _{CC} or ground.
A1	2	Address input 1. Connect directly to V _{CC} or ground.
RESET	3	Active low reset input. Connect to V _{CC} or V _{DPUM} ⁽¹⁾ through a pull-up resistor, if not used.
SD0	4	Serial data 0. Connect to V _{DPU0} ⁽¹⁾ through a pull-up resistor.
SC0	5	Serial clock 0. Connect to V _{DPU0} ⁽¹⁾ through a pull-up resistor.
SD1	6	Serial data 1. Connect to V _{DPU1} ⁽¹⁾ through a pull-up resistor.
SC1	7	Serial clock 1. Connect to V _{DPU1} ⁽¹⁾ through a pull-up resistor.
GND	8	Ground
SD2	9	Serial data 2. Connect to V _{DPU2} ⁽¹⁾ through a pull-up resistor.
SC2	10	Serial clock 2. Connect to V _{DPU2} ⁽¹⁾ through a pull-up resistor.
SD3	11	Serial data 3. Connect to V _{DPU3} ⁽¹⁾ through a pull-up resistor.
SC3	12	Serial clock 3. Connect to V _{DPU3} ⁽¹⁾ through a pull-up resistor.
A2	13	Address input 2. Connect directly to V _{CC} or ground.
SCL	14	Serial clock line. Connect to V _{DPUM} ⁽¹⁾ through a pull-up resistor.
SDA	15	Serial data line. Connect to V _{DPUM} ⁽¹⁾ through a pull-up resistor.
VCC	16	Supply power

(1) V_{DPUX} is the pull-up reference voltage for the associated data line. V_{DPUM} is the master I²C master reference voltage and V_{DPU0}-V_{DPU3} are the slave channel reference voltages.

7 Specifications

7.1 Absolute Maximum Ratings⁽¹⁾

over operating free-air temperature range (unless otherwise noted)

		MIN	MAX	UNIT
V _{CC}	Supply voltage range	-0.5	7	V
V _I	Input voltage range ⁽²⁾	-0.5	7	V
I _I	Input current		±20	mA
I _O	Output current		±25	mA
	Continuous current through V _{CC}		±100	mA
	Continuous current through GND		±100	mA
P _{tot}	Total power dissipation		400	mW
T _A	Operating free-air temperature range	-40	85	°C
T _{stg}	Storage temperature range	-65	150	°C

- (1) Stresses beyond those listed under "absolute maximum ratings" may cause permanent damage to the device. These are stress ratings only, and functional operation of the device at these or any other conditions beyond those indicated under "recommended operating conditions" is not implied. Exposure to absolute-maximum-rated conditions for extended periods may affect device reliability.
- (2) The input negative-voltage and output voltage ratings may be exceeded if the input and output current ratings are observed.

7.2 ESD Ratings

		VALUE	UNIT
V _(ESD)	Electrostatic discharge	Human-body model (HBM), per ANSI/ESDA/JEDEC JS-001 ⁽¹⁾	±4000
		Charged-device model (CDM), per JEDEC specification JESD22-C101 ⁽²⁾	±1500

- (1) JEDEC document JEP155 states that 500-V HBM allows safe manufacturing with a standard ESD control process. Manufacturing with less than 500-V HBM is possible with the necessary precautions.
- (2) JEDEC document JEP157 states that 250-V CDM allows safe manufacturing with a standard ESD control process. Manufacturing with less than 250-V CDM is possible with the necessary precautions.

7.3 Recommended Operating Conditions⁽¹⁾

		MIN	MAX	UNIT
V _{CC}	Supply voltage	1.65	5.5	V
V _{IH}	High-level input voltage	SCL, SDA	0.7 × V _{CC}	6
		A2–A0, RESET	0.7 × V _{CC}	V _{CC} + 0.5
V _{IL}	Low-level input voltage	SCL, SDA	-0.5	0.3 × V _{CC}
		A2–A0, RESET	-0.5	0.3 × V _{CC}
T _A	Operating free-air temperature	-40	85	°C

- (1) All unused inputs of the device must be held at V_{CC} or GND to ensure proper device operation. Refer to the TI application report, *Implications of Slow or Floating CMOS Inputs*, literature number SCBA004.

7.4 Thermal Information

THERMAL METRIC ⁽¹⁾	TCA9546A		UNIT	
	D	PW		
	16 PINS	16 PINS		
R _{θJA}	Junction-to-ambient thermal resistance	92.3	122.3	°C/W
R _{θJctop}	Junction-to-case (top) thermal resistance	52.3	56.6	
R _{θJB}	Junction-to-board thermal resistance	50.1	57.4	
ψ _{JT}	Junction-to-top characterization parameter	17.7	10.9	
ψ _{JB}	Junction-to-board characterization parameter	49.8	66.8	

- (1) For more information about traditional and new thermal metrics, see the *IC Package Thermal Metrics* application report, [SPRA953](#).

7.5 Electrical Characteristics⁽¹⁾

over recommended operating free-air temperature range (unless otherwise noted)

PARAMETER		TEST CONDITIONS		V _{CC}	MIN	TYP ⁽²⁾	MAX	UNIT
V _{PORR}	Power-on reset voltage, V _{CC} rising	No load,	V _I = V _{CC} or GND ⁽³⁾			1.2	1.5	V
V _{PORF}	Power-on reset voltage, V _{CC} falling ⁽⁴⁾	No load,	V _I = V _{CC} or GND ⁽³⁾		0.8	1		
V _{pass}	Switch output voltage	V _{SWin} = V _{CC} ,	I _{SWout} = -100 μA	5 V		3.6		V
				4.5 V to 5.5 V		2.6	4.5	
				3.3 V		1.9		
				3 V to 3.6 V	1.6		2.8	
				2.5 V		1.4		
				2.3 V to 2.7 V	1.0		1.8	
				1.8 V		0.8		
				1.65 V to 1.95 V	0.5		1.1	
I _{OL}	SDA	V _{OL} = 0.4 V		1.65 V to 5.5 V	3	7		mA
		V _{OL} = 0.6 V			6	10		
I _i	SCL, SDA	V _I = V _{CC} or GND ⁽³⁾		1.65 V to 5.5 V			±1	μA
	SC3–SC0, SD3–SD0						±1	
	A2–A0						±1	
	RESET						±1	
I _{CC}	Operating mode	f _{SCL} = 400 kHz	V _I = V _{CC} or GND ⁽³⁾ I _O = 0 t _{r,max} = 300 ns	5.5 V		50		μA
				3.6 V		20		
				2.7 V		11		
				1.65 V		6		
		f _{SCL} = 100 kHz	V _I = V _{CC} or GND ⁽³⁾ I _O = 0 t _{r,max} = 1 μs	5.5 V		35		
				3.6 V		14		
				2.7 V		5		
				1.65 V		2		
	Standby mode	Low inputs	V _I = GND ⁽³⁾ I _O = 0	5.5 V		1.6	2	
				3.6 V		1.0	1.3	
		2.7 V			0.7	1.1		
		1.65 V			0.4	0.55		
High inputs	V _I = V _{CC} I _O = 0	5.5 V		1.6	2			
		3.6 V		1.0	1.3			
		2.7 V		0.7	1.1			
		1.65 V		0.4	0.55			
ΔI _{CC}	Supply-current change	SCL, SDA	SCL or SDA input at 0.6 V, Other inputs at V _{CC} or GND ⁽³⁾	1.65 V to 5.5 V	2		15	μA
			SCL or SDA input at V _{CC} - 0.6 V, Other inputs at V _{CC} or GND ⁽³⁾	1.65 V to 5.5 V	2		15	
C _i	A2–A0	V _I = V _{CC} or GND ⁽³⁾		1.65 V to 5.5 V		4.5	6	pF
	RESET					4.5	5.5	
C _{i(OFF)} ⁽⁵⁾	SCL, SDA	V _I = V _{CC} or GND ⁽³⁾	Switch OFF	1.65 V to 5.5 V		15	19	pF
	SC3–SC0, SD3–SD0					6	8	

(1) For operation between specified voltage ranges, refer to the worst-case parameter in both applicable ranges.

(2) All typical values are at nominal supply voltage (1.8-V, 2.5-V, 3.3-V, or 5-V V_{CC}), T_A = 25°C.

(3) RESET = V_{CC} (held high) when all other input voltages, V_I = GND.

(4) The power-on reset circuit resets the I²C bus logic with V_{CC} < V_{PORF}.

(5) C_{i(OFF)} depends on internal capacitance and external capacitance added to the SCn lines when channels(s) are ON.

Electrical Characteristics⁽¹⁾ (continued)

over recommended operating free-air temperature range (unless otherwise noted)

PARAMETER		TEST CONDITIONS		V _{CC}	MIN	TYP ⁽²⁾	MAX	UNIT
R _{ON}	Switch on-state resistance	V _O = 0.4 V	I _O = 15 mA	4.5 V to 5.5 V	4	10	16	Ω
				3 V to 3.6 V	5	13	20	
		V _O = 0.4 V	I _O = 10 mA	2.3 V to 2.7 V	7	16	45	
				1.65 V to 1.95 V	10	25	70	

7.6 I²C Interface Timing Requirements

 over recommended operating free-air temperature range (unless otherwise noted) (see [Figure 5](#))

			STANDARD MODE I ² C BUS		FAST MODE I ² C BUS		UNIT
			MIN	MAX	MIN	MAX	
f _{scl}	I ² C clock frequency		0	100	0	400	kHz
t _{sch}	I ² C clock high time		4		0.6		μs
t _{scl}	I ² C clock low time		4.7		1.3		μs
t _{sp}	I ² C spike time			50		50	ns
t _{sds}	I ² C serial-data setup time		250		100		ns
t _{sdh}	I ² C serial-data hold time		0 ⁽¹⁾		0 ⁽¹⁾		μs
t _{icr}	I ² C input rise time			1000	20 + 0.1C _b ⁽²⁾	300	ns
t _{icf}	I ² C input fall time			300	20 + 0.1C _b ⁽²⁾	300	ns
t _{ocf}	I ² C output fall time	10-pF to 400-pF bus		300	20 + 0.1C _b ⁽²⁾	300	ns
t _{buf}	I ² C bus free time between stop and start		4.7		1.3		μs
t _{sts}	I ² C start or repeated start condition setup		4.7		0.6		μs
t _{sth}	I ² C start or repeated start condition hold		4		0.6		μs
t _{sps}	I ² C stop condition setup		4		0.6		μs
t _{vdL(Data)}	Valid-data time (high to low) ⁽³⁾	SCL low to SDA output low valid		1		1	μs
t _{vdH(Data)}	Valid-data time (low to high) ⁽³⁾	SCL low to SDA output high valid		0.6		0.6	μs
t _{vd(ack)}	Valid-data time of ACK condition	ACK signal from SCL low to SDA output low		1		1	μs
C _b	I ² C bus capacitive load			400		400	pF

(1) A device internally must provide a hold time of at least 300 ns for the SDA signal (referred to the V_{IH} min of the SCL signal), in order to bridge the undefined region of the falling edge of SCL.

(2) C_b = total bus capacitance of one bus line in pF

(3) Data taken using a 1-kΩ pullup resistor and 50-pF load (see [Figure 5](#))

7.7 Switching Characteristics

 over recommended operating free-air temperature range, C_L ≤ 100 pF (unless otherwise noted) (see [Figure 5](#))

PARAMETER		FROM (INPUT)	TO (OUTPUT)	MIN	MAX	UNIT
t _{pd} ⁽¹⁾	Propagation delay time	R _{ON} = 20 Ω, C _L = 15 pF	SDA or SCL	SDn or SCn	0.3	ns
		R _{ON} = 20 Ω, C _L = 50 pF			1	

(1) The propagation delay is the calculated RC time constant of the typical ON-state resistance of the switch and the specified load capacitance, when driven by an ideal voltage source (zero output impedance).

7.8 Interrupt and Reset Timing Requirements

over recommended operating free-air temperature range (unless otherwise noted)

PARAMETER		MIN	MAX	UNIT
t_{WL}	Pulse duration, $\overline{\text{RESET}}$ low	6		ns
$t_{rst}^{(1)}$	$\overline{\text{RESET}}$ time (SDA clear)		500	ns
$t_{REC(STA)}$	Recovery time from $\overline{\text{RESET}}$ to start	0		ns

(1) t_{rst} is the propagation delay measured from the time the $\overline{\text{RESET}}$ pin is first asserted low to the time the SDA pin is asserted high, signaling a stop condition. It must be a minimum of t_{WL} .

7.9 Typical Characteristics

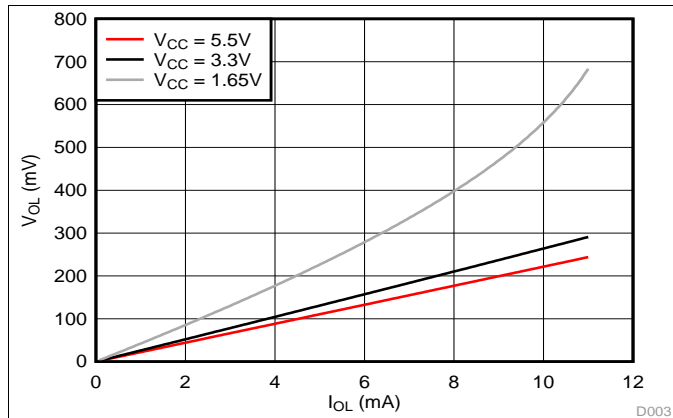

Figure 1. SDA Output Low Voltage (V_{OL}) vs Load Current (I_{OL}) at Three V_{CC} Levels

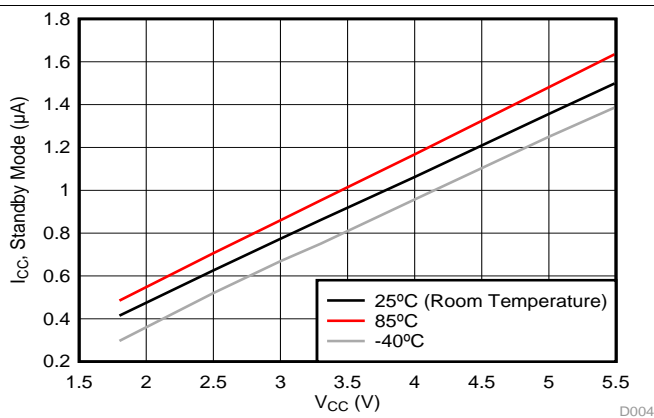

Figure 2. Standby Current (I_{CC}) vs Supply Voltage (V_{CC}) at Three Temperature Points

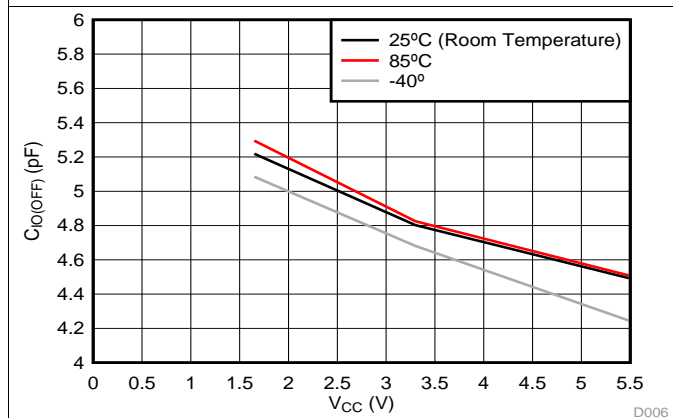

Figure 3. Slave channel (SCn/SDn) capacitance ($C_{iO(OFF)}$) vs. Supply Voltage (V_{CC}) at Three Temperature Points

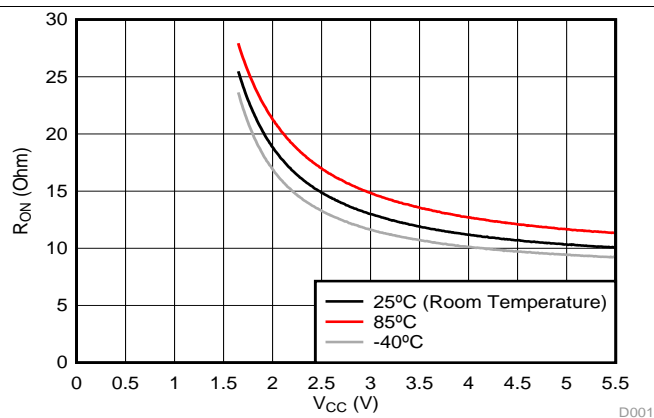
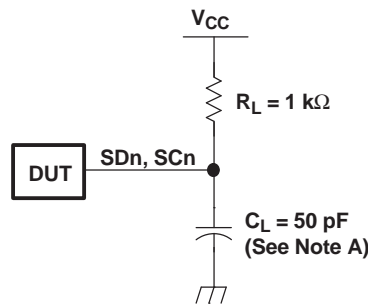
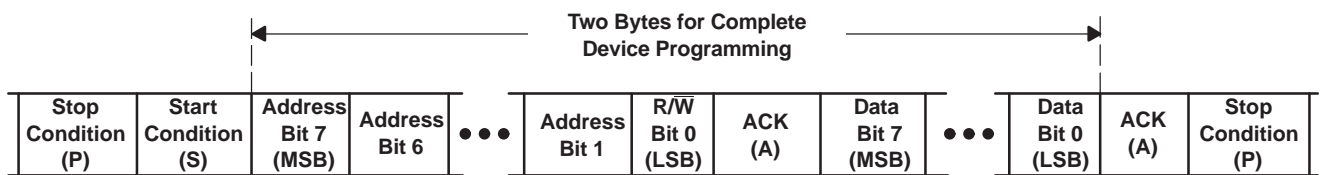

Figure 4. ON-Resistance (R_{ON}) vs Supply Voltage (V_{CC}) at Three Temperatures

8 Parameter Measurement Information



I²C PORT LOAD CONFIGURATION



BYTE	DESCRIPTION
1	I ² C address + R/W
2	Control register data

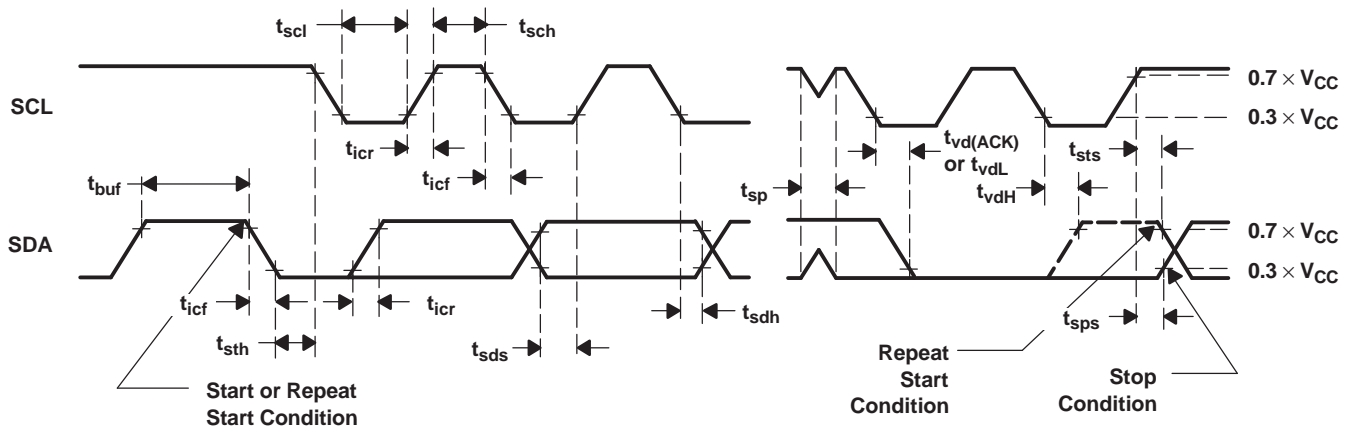

VOLTAGE WAVEFORMS

- A. C_L includes probe and jig capacitance.
- B. All input pulses are supplied by generators having the following characteristics: PRR \leq 10 MHz, $Z_O = 50 \Omega$, $t_r/t_f \leq 30$ ns.
- C. The outputs are measured one at a time, with one transition per measurement.

Figure 5. I²C Interface Load Circuit, Byte Descriptions, and Voltage Waveforms

Parameter Measurement Information (continued)

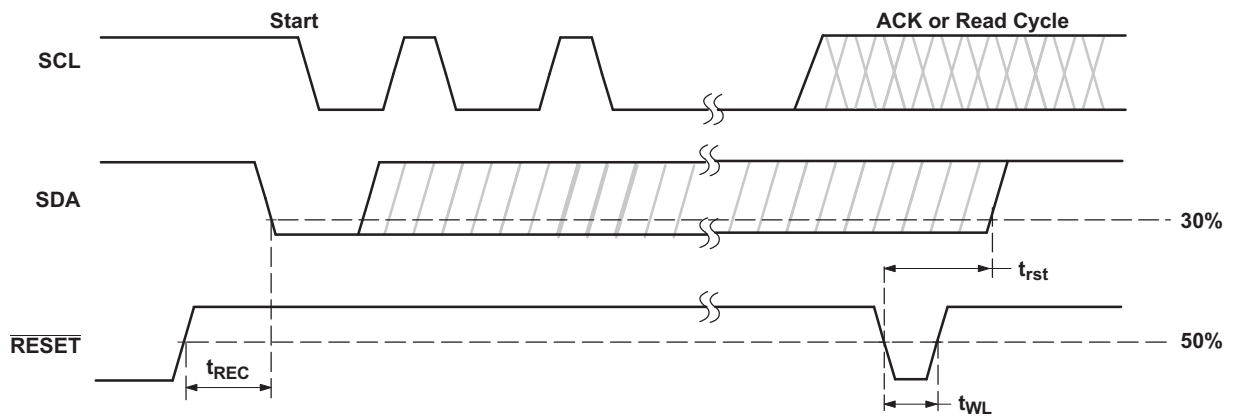

Figure 6. Reset Timing

9 Detailed Description

9.1 Overview

The TCA9546A is a 4-channel, bidirectional translating I²C switch. The master SCL/SDA signal pair is directed to four channels of slave devices, SC0/SD0-SC3/SD3. Any individual downstream channel can be selected as well as any combination of the four channels.

The device offers an active-low $\overline{\text{RESET}}$ input which resets the state machine and allows the TCA9546A to recover should one of the downstream I²C buses get stuck in a low state. The state machine of the device can also be reset by cycling the power supply, V_{CC} , also known as a power-on reset (POR). Both the RESET function and a POR will cause all channels to be deselected.

The connections of the I²C data path are controlled by the same I²C master device that is switched to communicate with multiple I²C slaves. After the successful acknowledgment of the slave address (hardware selectable by A0 and A1 pins), a single 8-bit control register is written to or read from to determine the selected channels.

The TCA9546A may also be used for voltage translation, allowing the use of different bus voltages on each SCn/SDn pair such that 1.8-V, 2.5-V, or 3.3-V parts can communicate with 5-V parts. This is achieved by using external pull-up resistors to pull the bus up to the desired voltage for the master and each slave channel.

9.2 Functional Block Diagram

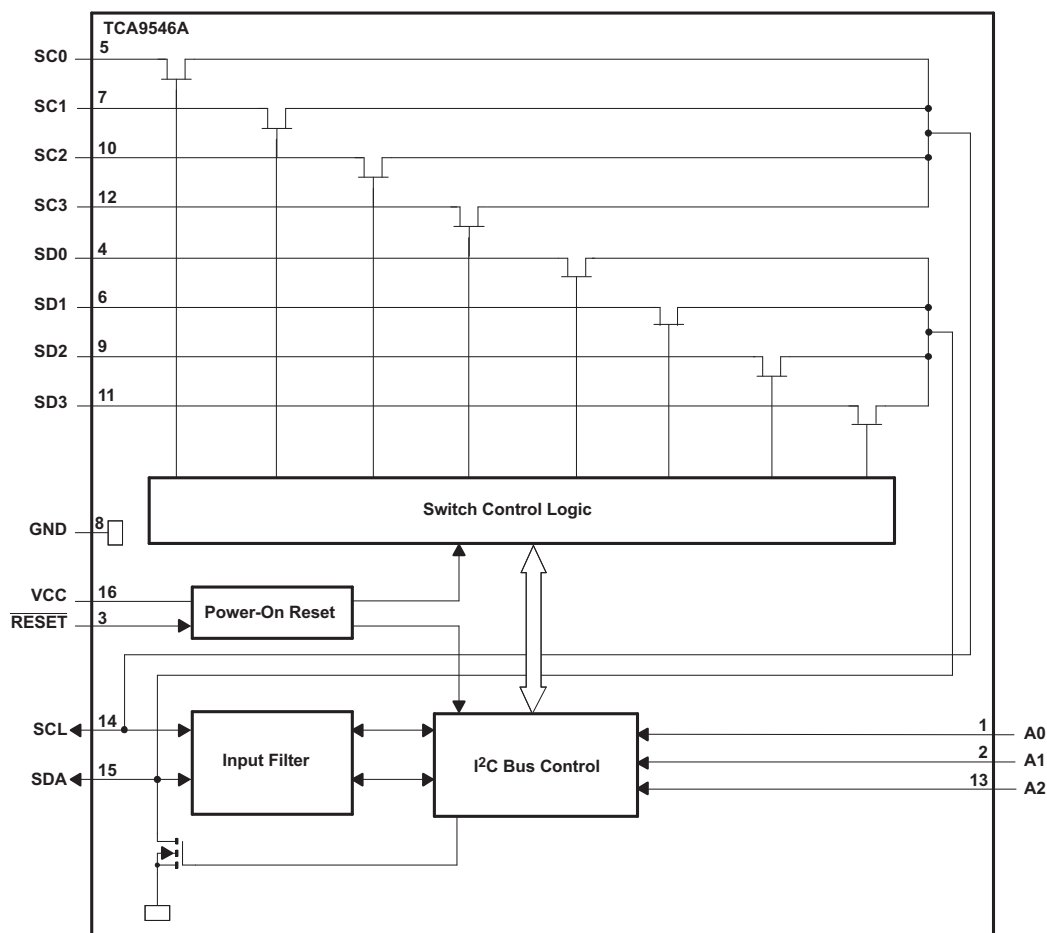

9.3 Feature Description

The TCA9546A is a 4-channel, bidirectional translating switch for I²C buses that supports Standard-Mode (100 kHz) and Fast-Mode (400 kHz) operation. The TCA9546A features I²C control using a single 8-bit control register in which the four least significant bits control the enabling and disabling of the 4 switch channels of I²C data flow. Depending on the application, voltage translation of the I²C bus can also be achieved using the TCA9546A to allow 1.8-V, 2.5-V, or 3.3-V parts to communicate with 5-V parts. Additionally, in the event that communication on the I²C bus enters a fault state, the TCA9546A can be reset to resume normal operation using the $\overline{\text{RESET}}$ pin feature or by a power-on reset which results from cycling power to the device.

9.4 Device Functional Modes

9.4.1 $\overline{\text{RESET}}$ Input

The $\overline{\text{RESET}}$ input is an active-low signal that may be used to recover from a bus-fault condition. When this signal is asserted low for a minimum of t_{WL} , the TCA9546A resets its registers and I²C state machine and deselects all channels. The $\overline{\text{RESET}}$ input must be connected to V_{CC} through a pull-up resistor.

9.4.2 Power-On Reset

When power is applied to V_{CC} , an internal power-on reset holds the TCA9546A in a reset condition until V_{CC} has reached V_{POR} . At this point, the reset condition is released, and the TCA9546A registers and I²C state machine are initialized to their default states, all zeroes, causing all the channels to be deselected. Thereafter, V_{CC} must be lowered below V_{POR} to reset the device.

9.5 Programming

9.5.1 I²C Interface

The I²C bus is for two-way two-line communication between different ICs or modules. The two lines are a serial data line (SDA) and a serial clock line (SCL). Both lines must be connected to a positive supply via a pullup resistor when connected to the output stages of a device. Data transfer can be initiated only when the bus is not busy.

One data bit is transferred during each clock pulse. The data on the SDA line must remain stable during the high period of the clock pulse, as changes in the data line at this time are interpreted as control signals (see Figure 7).

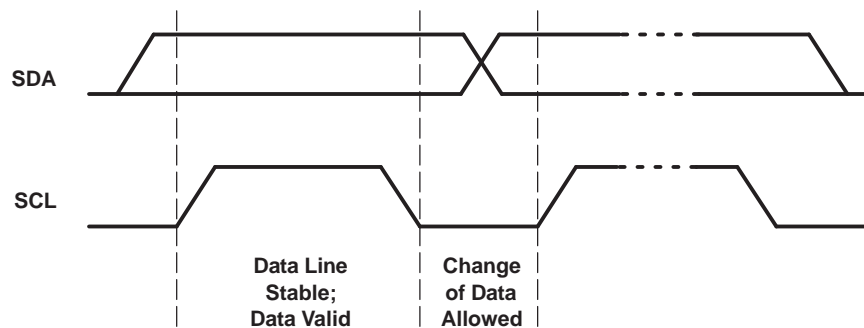
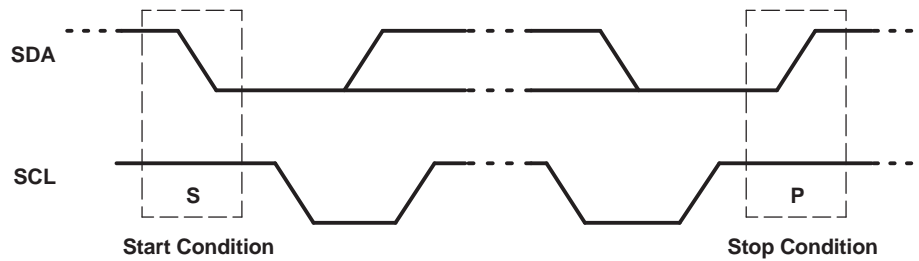
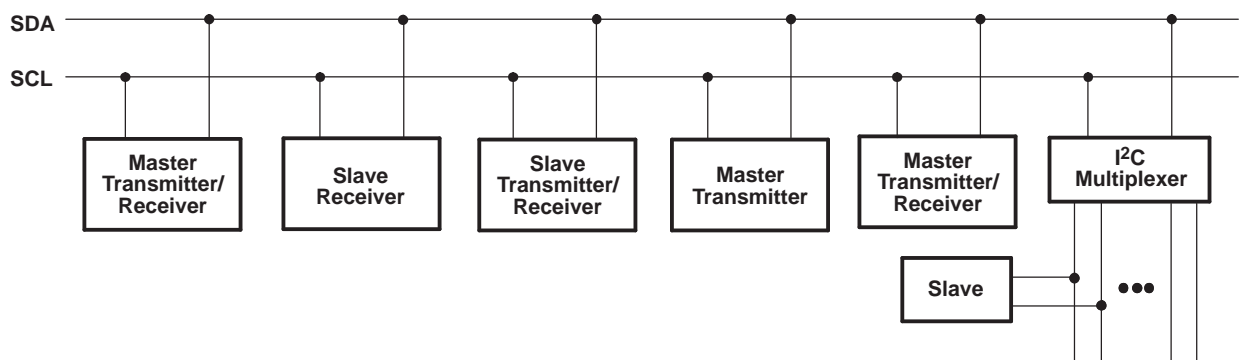

Figure 7. Bit Transfer

Both data and clock lines remain high when the bus is not busy. A high-to-low transition of the data line while the clock is high is defined as the start condition (S). A low-to-high transition of the data line while the clock is high is defined as the stop condition (P) (see Figure 8).

Programming (continued)

Figure 8. Definition of Start and Stop Conditions

A device generating a message is a transmitter; a device receiving is the receiver. The device that controls the message is the master, and the devices that are controlled by the master are the slaves (see [Figure 9](#)).

Figure 9. System Configuration

The number of data bytes transferred between the start and the stop conditions from transmitter to receiver is not limited. Each byte of eight bits is followed by one acknowledge (ACK) bit. The transmitter must release the SDA line before the receiver can send an ACK bit.

When a slave receiver is addressed, it must generate an ACK after the reception of each byte. Also, a master must generate an ACK after the reception of each byte that has been clocked out of the slave transmitter. The device that acknowledges must pull down the SDA line during the ACK clock pulse so that the SDA line is stable low during the high pulse of the ACK-related clock period (see [Figure 10](#)). Setup and hold times must be taken into account.

Programming (continued)

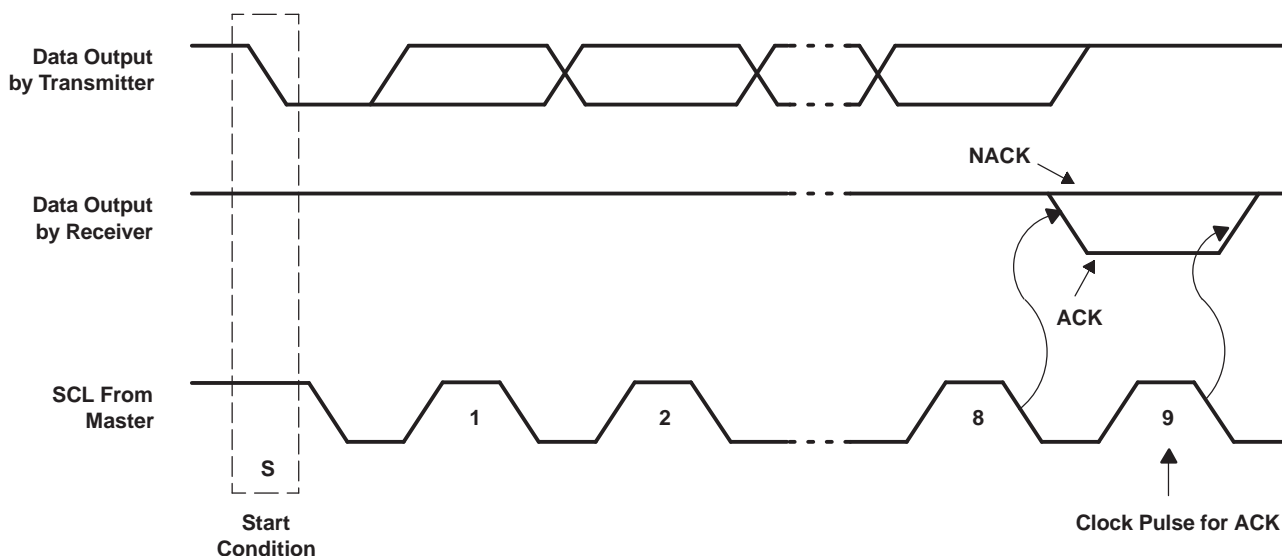

Figure 10. Acknowledgment on the I²C Bus

Data is transmitted to the TCA9546A control register using the write mode shown in Figure 11.

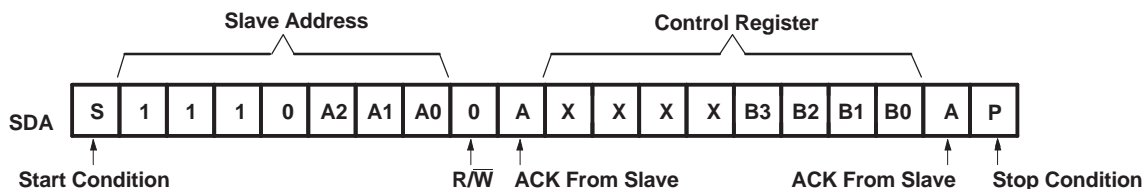

Figure 11. Write Control Register

Data is read from the TCA9546A control register using the read mode shown in Figure 12.

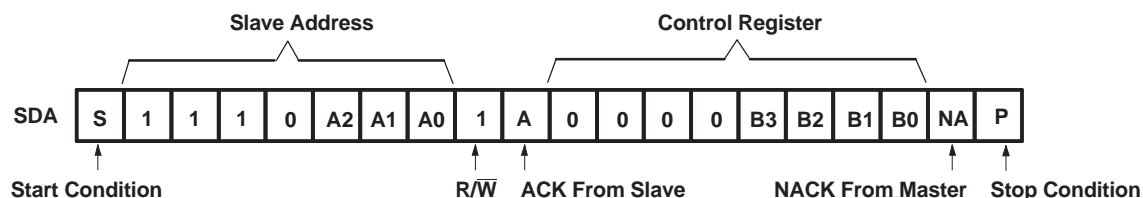

Figure 12. Read Control Register

9.6 Control Register

9.6.1 Device Address

Following a start condition, the bus master must output the address of the slave it is accessing. The address of the TCA9546A is shown in [Figure 13](#). To conserve power, no internal pullup resistors are incorporated on the hardware-selectable address pins, and they must be pulled high or low.

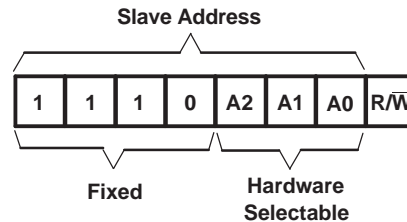

Figure 13. TCA9546A Address

The last bit of the slave address defines the operation to be performed. When set to a logic 1, a read is selected, while a logic 0 selects a write operation.

9.6.2 Control Register Description

Following the successful acknowledgment of the slave address, the bus master sends a byte to the TCA9546A, which is stored in the control register (see [Figure 14](#)). If multiple bytes are received by the TCA9546A, it will save the last byte received. This register can be written and read via the I²C bus.

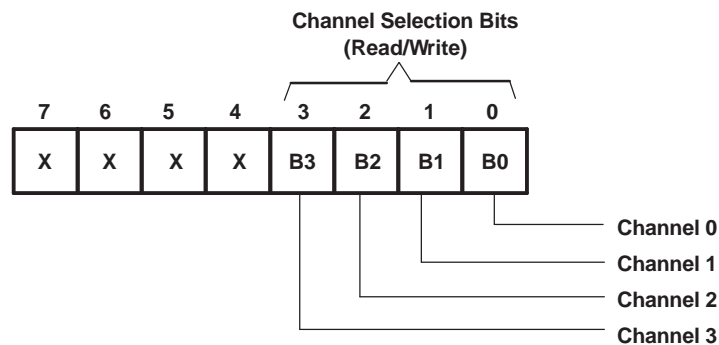

Figure 14. Control Register

9.6.3 Control Register Definition

One or several SC_n/SD_n downstream pairs, or channels, are selected by the contents of the control register (see [Table 1](#)). This register is written after the TCA9546A has been addressed. The four LSBs of the control byte are used to determine which channel or channels are to be selected. When a channel is selected, the channel becomes active after a stop condition has been placed on the I²C bus. This ensures that all SC_n/SD_n lines are in a high state when the channel is made active, so that no false conditions are generated at the time of connection. A stop condition always must occur right after the acknowledge cycle.

Control Register (continued)
Table 1. Control Register Write (Channel Selection), Control Register Read (Channel Status)⁽¹⁾

B7	B6	B5	B4	B3	B2	B1	B0	COMMAND
X	X	X	X	X	X	X	0	Channel 0 disabled
							1	Channel 0 enabled
X	X	X	X	X	X	X	0	Channel 1 disabled
							1	Channel 1 enabled
X	X	X	X	X	X	X	0	Channel 2 disabled
							1	Channel 2 enabled
X	X	X	X	X	X	X	0	Channel 3 disabled
							1	Channel 3 enabled
0	0	0	0	0	0	0	0	No channel selected, power-up/reset default state

(1) Several channels can be enabled at the same time. For example, B3 = 0, B2 = 1, B1 = 1, B0 = 0 means that channels 0 and 3 are disabled, and channels 1 and 2 are enabled. Care should be taken not to exceed the maximum bus capacity.

10 Application and Implementation

10.1 Application Information

Applications of the TCA9546A will contain an I²C (or SMBus) master device and up to four I²C slave devices. The downstream channels are ideally used to resolve I²C slave address conflicts. For example, if four identical digital temperature sensors are needed in the application, one sensor can be connected at each channel: 0, 1, 2, and 3. When the temperature at a specific location needs to be read, the appropriate channel can be enabled and all other channels switched off, the data can be retrieved, and the I²C master can move on and read the next channel.

In an application where the I²C bus will contain many additional slave devices that do not result in I²C slave address conflicts, these slave devices can be connected to any desired channel to distribute the total bus capacitance across multiple channels. If multiple switches will be enabled simultaneously, additional design requirements must be considered (See [Design Requirements](#) and [Detailed Design Procedure](#)).

10.2 Typical Application

A typical application of the TCA9546A will contain anywhere from 1 to 5 separate data pull-up voltages, V_{DPUX} , one for the master device (V_{DPUM}) and one for each of the selectable slave channels ($V_{DPU0} - V_{DPU3}$). In the event where the master device and all slave devices operate at the same voltage, then the pass voltage, $V_{PASS} = V_{DPUM}$. Once the maximum V_{PASS} is known, V_{CC} can be selected easily using [Figure 16](#). In an application where voltage translation is necessary, additional design requirements must be considered (See [Design Requirements](#)).

[Figure 15](#) shows an application in which the TCA9546A can be used.

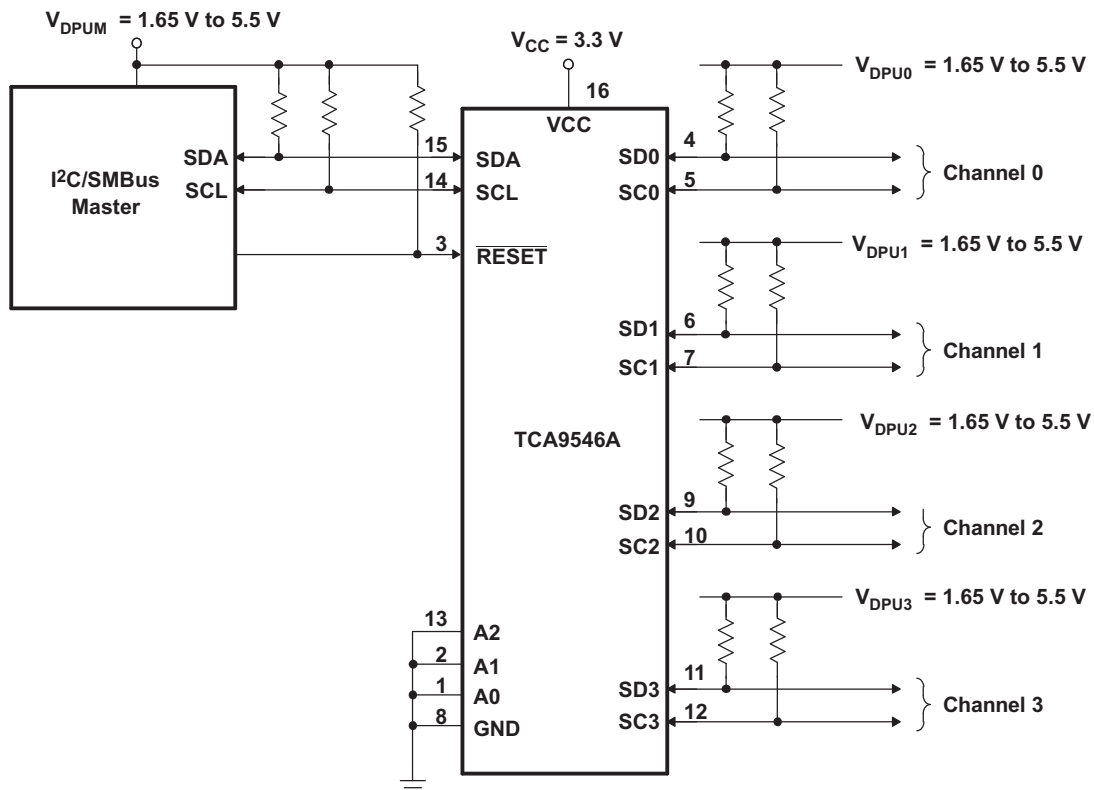

Figure 15. TCA9546A Typical Application Schematic

Typical Application (continued)

10.2.1 Design Requirements

The A0, A1, and A2 pins are hardware selectable to control the slave address of the TCA9546A. These pins may be tied directly to GND or V_{CC} in the application.

If multiple slave channels will be activated simultaneously in the application, then the total I_{OL} from SCL/SDA to GND on the master side will be the sum of the currents through all pull-up resistors, R_p .

The pass-gate transistors of the TCA9546A are constructed such that the V_{CC} voltage can be used to limit the maximum voltage that is passed from one I²C bus to another.

Figure 16 shows the voltage characteristics of the pass-gate transistors (note that the graph was generated using data specified in the [Electrical Characteristics](#) section of this data sheet). In order for the TCA9546A to act as a voltage translator, the V_{pass} voltage must be equal to or lower than the lowest bus voltage. For example, if the main bus is running at 5 V and the downstream buses are 3.3 V and 2.7 V, V_{pass} must be equal to or below 2.7 V to effectively clamp the downstream bus voltages. As shown in Figure 16, $V_{pass(max)}$ is 2.7 V when the TCA9546A supply voltage is 4 V or lower, so the TCA9546A supply voltage could be set to 3.3 V. Pull-up resistors then can be used to bring the bus voltages to their appropriate levels (see Figure 15).

10.2.2 Detailed Design Procedure

Once all the slaves are assigned to the appropriate slave channels and bus voltages are identified, the pull-up resistors, R_p , for each of the buses need to be selected appropriately. The minimum pull-up resistance is a function of V_{DPUX} , $V_{OL(max)}$, and I_{OL} :

$$R_{p(min)} = \frac{V_{DPUX} - V_{OL(max)}}{I_{OL}} \quad (1)$$

The maximum pull-up resistance is a function of the maximum rise time, t_r (300 ns for fast-mode operation, $f_{SCL} = 400$ kHz) and bus capacitance, C_b :

$$R_{p(max)} = \frac{t_r}{0.8473 \times C_b} \quad (2)$$

The maximum bus capacitance for an I²C bus must not exceed 400 pF for fast-mode operation. The bus capacitance can be approximated by adding the capacitance of the TCA9546A, $C_{iO(OFF)}$, the capacitance of wires/connections/traces, and the capacitance of each individual slave on a given channel. If multiple channels will be activated simultaneously, each of the slaves on all channels will contribute to total bus capacitance.

Typical Application (continued)

10.2.3 TCA9546A Application Curves

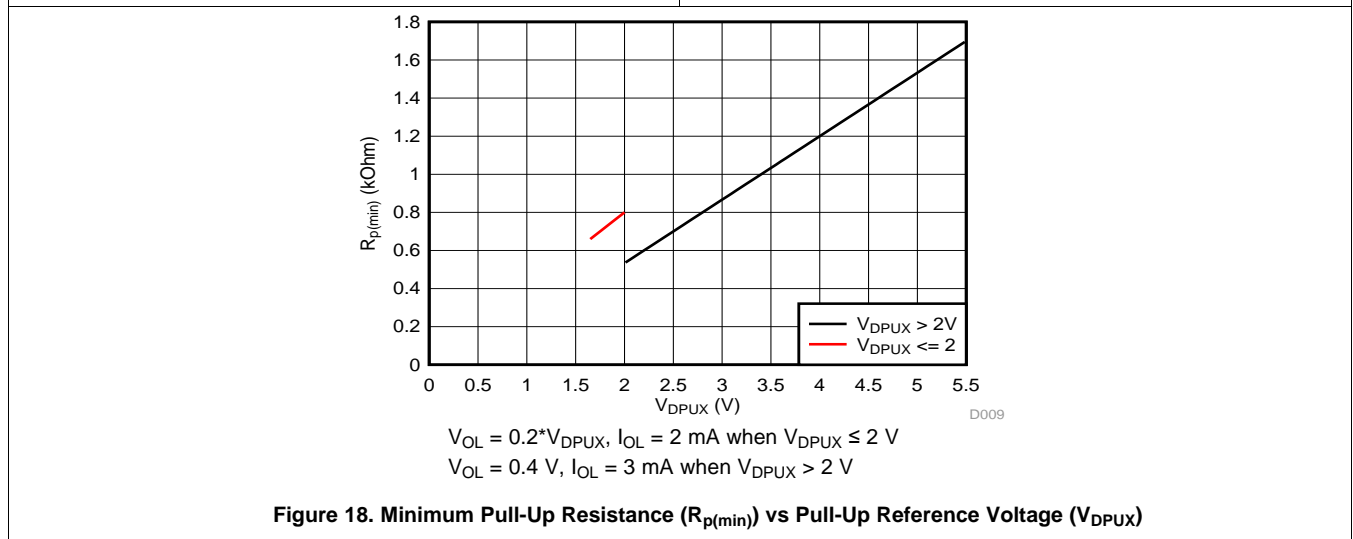
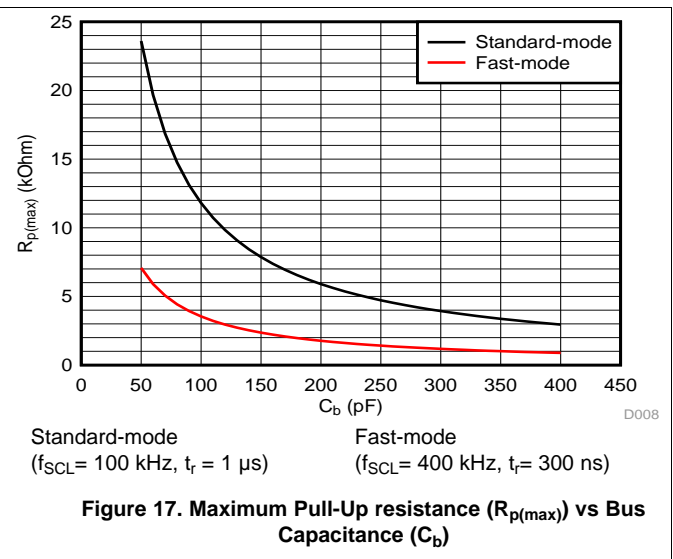
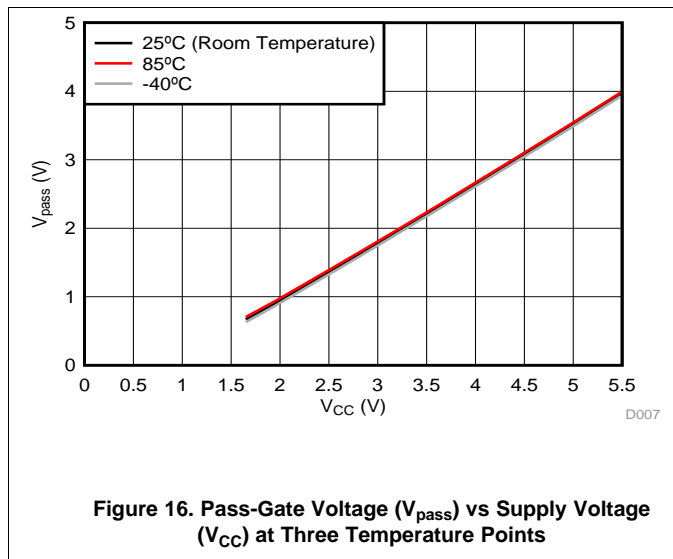

11 Power Supply Recommendations

The operating power-supply voltage range of the TCA9546A is 1.65 V to 5.5 V applied at the VCC pin. When the TCA9546A is powered on for the first time or anytime the device needs to be reset by cycling the power supply, the power-on reset requirements must be followed to ensure the I²C bus logic is initialized properly.

11.1 Power-On Reset Requirements

In the event of a glitch or data corruption, TCA9546A can be reset to its default conditions by using the power-on reset feature. Power-on reset requires that the device go through a power cycle to be completely reset. This reset also happens when the device is powered on for the first time in an application.

A power-on reset is shown in Figure 19.

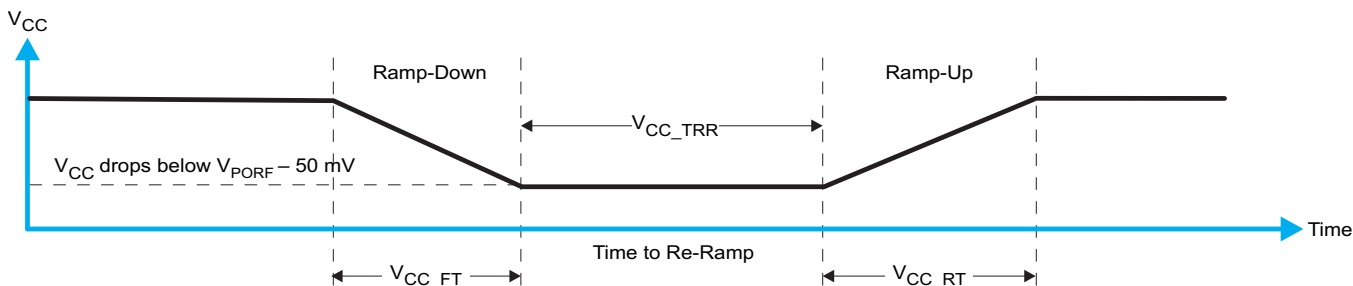

Figure 19. V_{CC} is Lowered Below the POR Threshold, Then Ramped Back Up to V_{CC}

Table 2 specifies the performance of the power-on reset feature for TCA9546A for both types of power-on reset.

Table 2. Recommended Supply Sequencing And Ramp Rates⁽¹⁾

PARAMETER		MIN	TYP	MAX	UNIT
V _{CC_FT}	Fall time	See Figure 19	1	100	ms
V _{CC_RT}	Rise time	See Figure 19	0.1	100	ms
V _{CC_TRR}	Time to re-ramp (when V _{CC} drops below V _{PORF(min)} – 50 mV or when V _{CC} drops to GND)	See Figure 19	40		μs
V _{CC_GH}	Level that V _{CC} can glitch down to, but not cause a functional disruption when V _{CC_GW} = 1 μs	See Figure 20		1.2	V
V _{CC_GW}	Glitch width that will not cause a functional disruption when V _{CC_GH} = 0.5 × V _{CC}	See Figure 20		10	μs
V _{PORF}	Voltage trip point of POR on falling V _{CC}	See Figure 21	0.8	1.25	V
V _{PORR}	Voltage trip point of POR on rising V _{CC}	See Figure 21	1.05	1.5	V

(1) All supply sequencing and ramp rate values are measured at T_A = 25°C

Glitches in the power supply can also affect the power-on reset performance of this device. The glitch width (V_{CC_GW}) and height (V_{CC_GH}) are dependent on each other. The bypass capacitance, source impedance, and device impedance are factors that affect power-on reset performance. Figure 20 and Table 2 provide more information on how to measure these specifications.

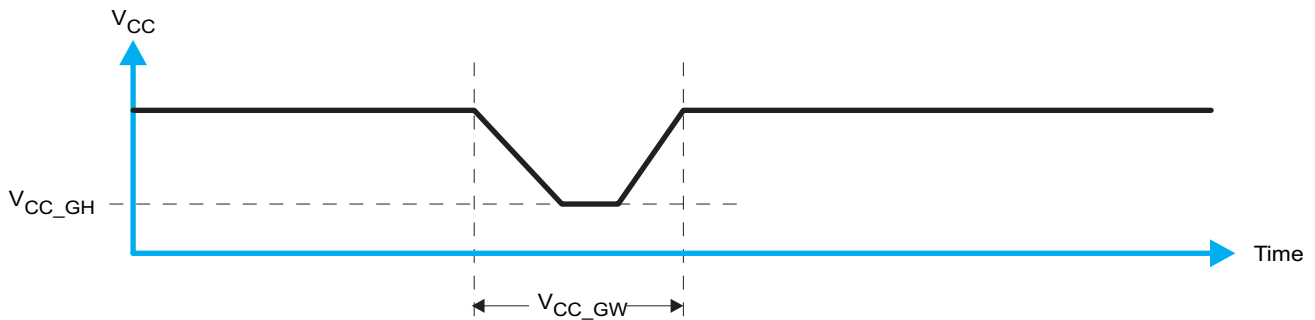

Figure 20. Glitch Width and Glitch Height

V_{POR} is critical to the power-on reset. V_{POR} is the voltage level at which the reset condition is released and all the registers and the I²C/SMBus state machine are initialized to their default states. The value of V_{POR} differs based on the V_{CC} being lowered to or from 0. Figure 21 and Table 2 provide more details on this specification.

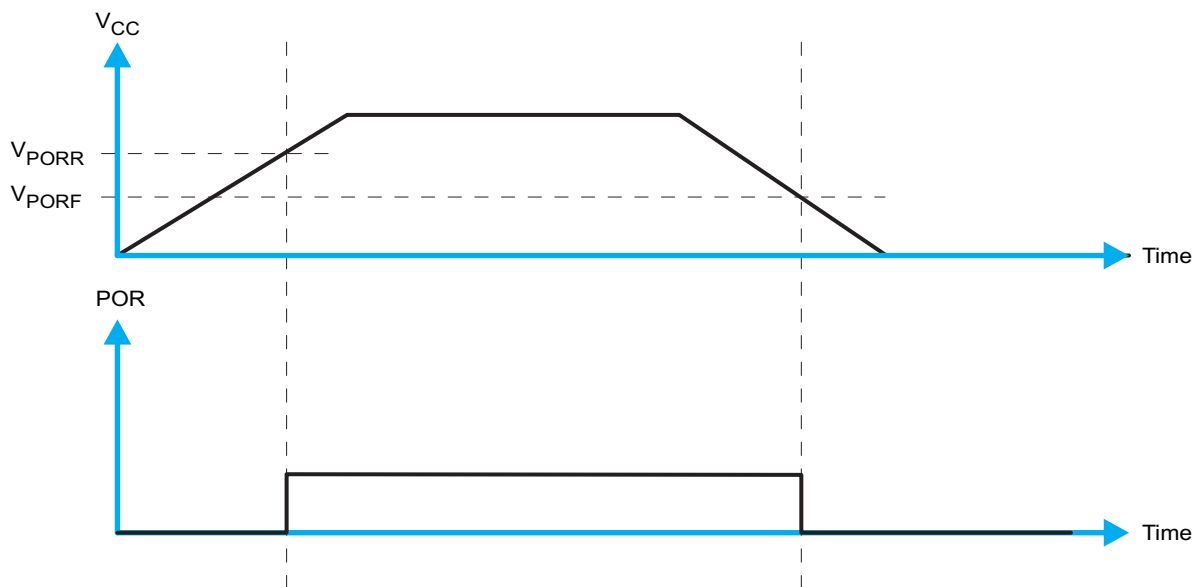

Figure 21. V_{POR}

12 Layout

12.1 Layout Guidelines

For PCB layout of the TCA9546A, common PCB layout practices should be followed but additional concerns related to high-speed data transfer such as matched impedances and differential pairs are not a concern for I²C signal speeds. It is common to have a dedicated ground plane on an inner layer of the board and pins that are connected to ground should have a low-impedance path to the ground plane in the form of wide polygon pours and multiple vias. By-pass and de-coupling capacitors are commonly used to control the voltage on the VCC pin, using a larger capacitor to provide additional power in the event of a short power supply glitch and a smaller capacitor to filter out high-frequency ripple.

In an application where voltage translation is not required, all V_{DPUX} voltages and V_{CC} could be at the same potential and a single copper plane could connect all of pull-up resistors to the appropriate reference voltage. In an application where voltage translation is required, V_{DPU0}, V_{DPU1}, V_{DPU2}, and V_{DPU3} may all be on the same layer of the board with split planes to isolate different voltage potentials.

To reduce the total I²C bus capacitance added by PCB parasitics, data lines (SC_n and SD_n) should be as short as possible and the widths of the traces should also be minimized (e.g. 5-10 mils depending on copper weight).

12.2 Layout Example

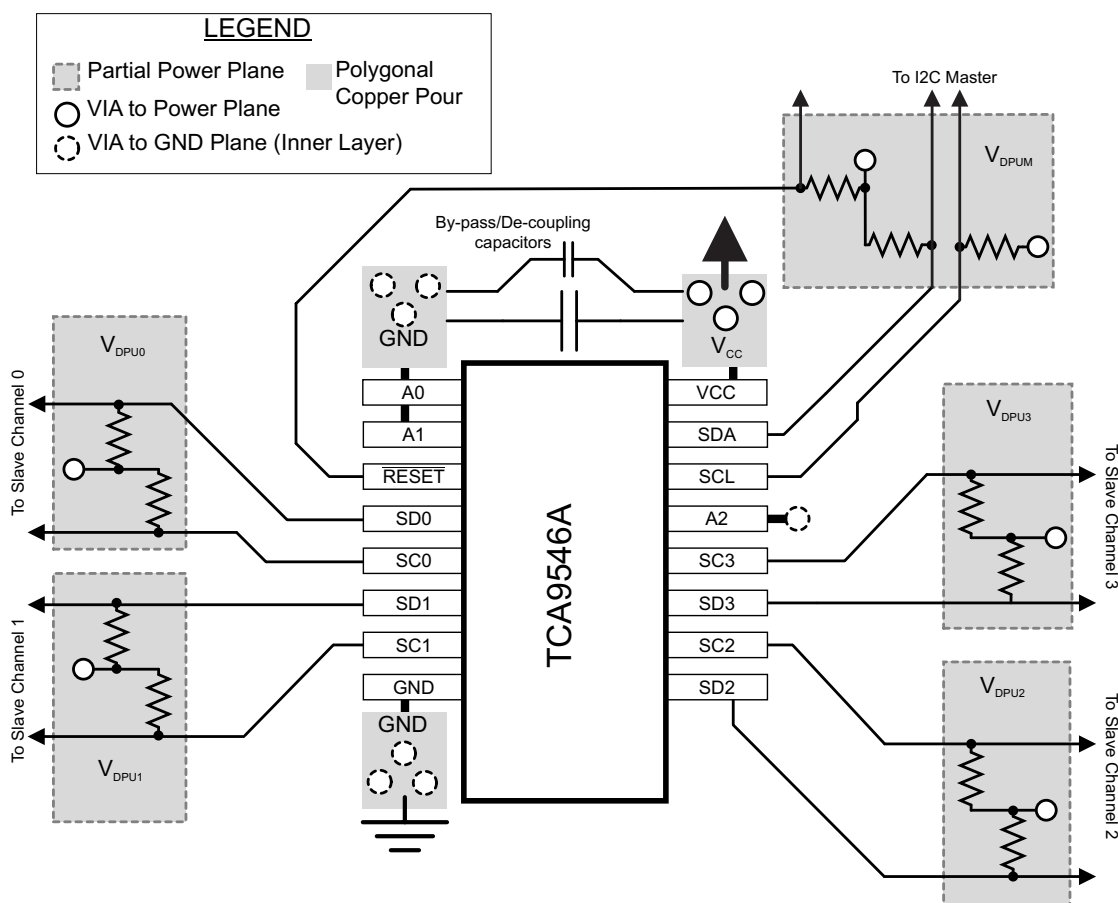

13 Device and Documentation Support

13.1 Trademarks

All trademarks are the property of their respective owners.

13.2 Electrostatic Discharge Caution



These devices have limited built-in ESD protection. The leads should be shorted together or the device placed in conductive foam during storage or handling to prevent electrostatic damage to the MOS gates.

13.3 Glossary

[SLYZ022](#) — *TI Glossary*.

This glossary lists and explains terms, acronyms, and definitions.

14 Mechanical, Packaging, and Orderable Information

The following pages include mechanical, packaging, and orderable information. This information is the most current data available for the designated devices. This data is subject to change without notice and revision of this document. For browser-based versions of this data sheet, refer to the left-hand navigation

PACKAGING INFORMATION

Orderable Device	Status (1)	Package Type	Package Drawing	Pins	Package Qty	Eco Plan (2)	Lead/Ball Finish (6)	MSL Peak Temp (3)	Op Temp (°C)	Device Marking (4/5)	Samples
TCA9546ADR	ACTIVE	SOIC	D	16	2500	Green (RoHS & no Sb/Br)	CU NIPDAU	Level-1-260C-UNLIM	-40 to 85	TCA9546A	Samples
TCA9546APWR	ACTIVE	TSSOP	PW	16	2000	Green (RoHS & no Sb/Br)	CU NIPDAU	Level-1-260C-UNLIM	-40 to 85	PW546A	Samples

(1) The marketing status values are defined as follows:

ACTIVE: Product device recommended for new designs.

LIFEBUY: TI has announced that the device will be discontinued, and a lifetime-buy period is in effect.

NRND: Not recommended for new designs. Device is in production to support existing customers, but TI does not recommend using this part in a new design.

PREVIEW: Device has been announced but is not in production. Samples may or may not be available.

OBSOLETE: TI has discontinued the production of the device.

(2) Eco Plan - The planned eco-friendly classification: Pb-Free (RoHS), Pb-Free (RoHS Exempt), or Green (RoHS & no Sb/Br) - please check <http://www.ti.com/productcontent> for the latest availability information and additional product content details.

TBD: The Pb-Free/Green conversion plan has not been defined.

Pb-Free (RoHS): TI's terms "Lead-Free" or "Pb-Free" mean semiconductor products that are compatible with the current RoHS requirements for all 6 substances, including the requirement that lead not exceed 0.1% by weight in homogeneous materials. Where designed to be soldered at high temperatures, TI Pb-Free products are suitable for use in specified lead-free processes.

Pb-Free (RoHS Exempt): This component has a RoHS exemption for either 1) lead-based flip-chip solder bumps used between the die and package, or 2) lead-based die adhesive used between the die and leadframe. The component is otherwise considered Pb-Free (RoHS compatible) as defined above.

Green (RoHS & no Sb/Br): TI defines "Green" to mean Pb-Free (RoHS compatible), and free of Bromine (Br) and Antimony (Sb) based flame retardants (Br or Sb do not exceed 0.1% by weight in homogeneous material)

(3) MSL, Peak Temp. - The Moisture Sensitivity Level rating according to the JEDEC industry standard classifications, and peak solder temperature.

(4) There may be additional marking, which relates to the logo, the lot trace code information, or the environmental category on the device.

(5) Multiple Device Markings will be inside parentheses. Only one Device Marking contained in parentheses and separated by a "~" will appear on a device. If a line is indented then it is a continuation of the previous line and the two combined represent the entire Device Marking for that device.

(6) Lead/Ball Finish - Orderable Devices may have multiple material finish options. Finish options are separated by a vertical ruled line. Lead/Ball Finish values may wrap to two lines if the finish value exceeds the maximum column width.

Important Information and Disclaimer: The information provided on this page represents TI's knowledge and belief as of the date that it is provided. TI bases its knowledge and belief on information provided by third parties, and makes no representation or warranty as to the accuracy of such information. Efforts are underway to better integrate information from third parties. TI has taken and continues to take reasonable steps to provide representative and accurate information but may not have conducted destructive testing or chemical analysis on incoming materials and chemicals. TI and TI suppliers consider certain information to be proprietary, and thus CAS numbers and other limited information may not be available for release.

In no event shall TI's liability arising out of such information exceed the total purchase price of the TI part(s) at issue in this document sold by TI to Customer on an annual basis.

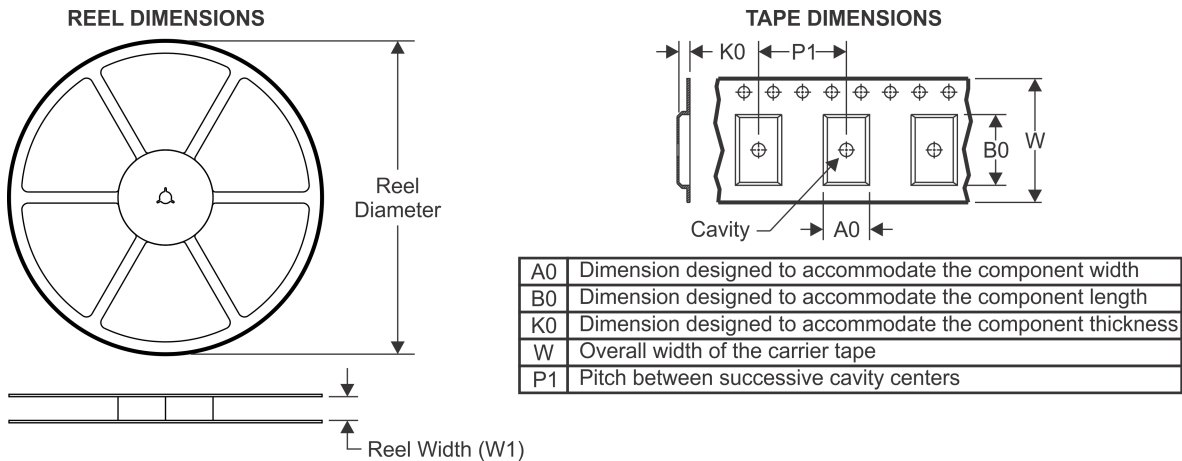
TAPE AND REEL INFORMATION

QUADRANT ASSIGNMENTS FOR PIN 1 ORIENTATION IN TAPE

*All dimensions are nominal

Device	Package Type	Package Drawing	Pins	SPQ	Reel Diameter (mm)	Reel Width W1 (mm)	A0 (mm)	B0 (mm)	K0 (mm)	P1 (mm)	W (mm)	Pin1 Quadrant
TCA9546ADR	SOIC	D	16	2500	330.0	16.4	6.5	10.3	2.1	8.0	16.0	Q1
TCA9546APWR	TSSOP	PW	16	2000	330.0	12.4	6.9	5.6	1.6	8.0	12.0	Q1

TAPE AND REEL BOX DIMENSIONS

*All dimensions are nominal



Device	Package Type	Package Drawing	Pins	SPQ	Length (mm)	Width (mm)	Height (mm)
TCA9546ADR	SOIC	D	16	2500	367.0	367.0	38.0
TCA9546APWR	TSSOP	PW	16	2000	367.0	367.0	35.0

D (R-PDSO-G16)

PLASTIC SMALL OUTLINE



4040047-6/M 06/11

- NOTES:
- A. All linear dimensions are in inches (millimeters).
 - B. This drawing is subject to change without notice.
 -  Body length does not include mold flash, protrusions, or gate burrs. Mold flash, protrusions, or gate burrs shall not exceed 0.006 (0,15) each side.
 -  Body width does not include interlead flash. Interlead flash shall not exceed 0.017 (0,43) each side.
 - E. Reference JEDEC MS-012 variation AC.

PW (R-PDSO-G16)

PLASTIC SMALL OUTLINE

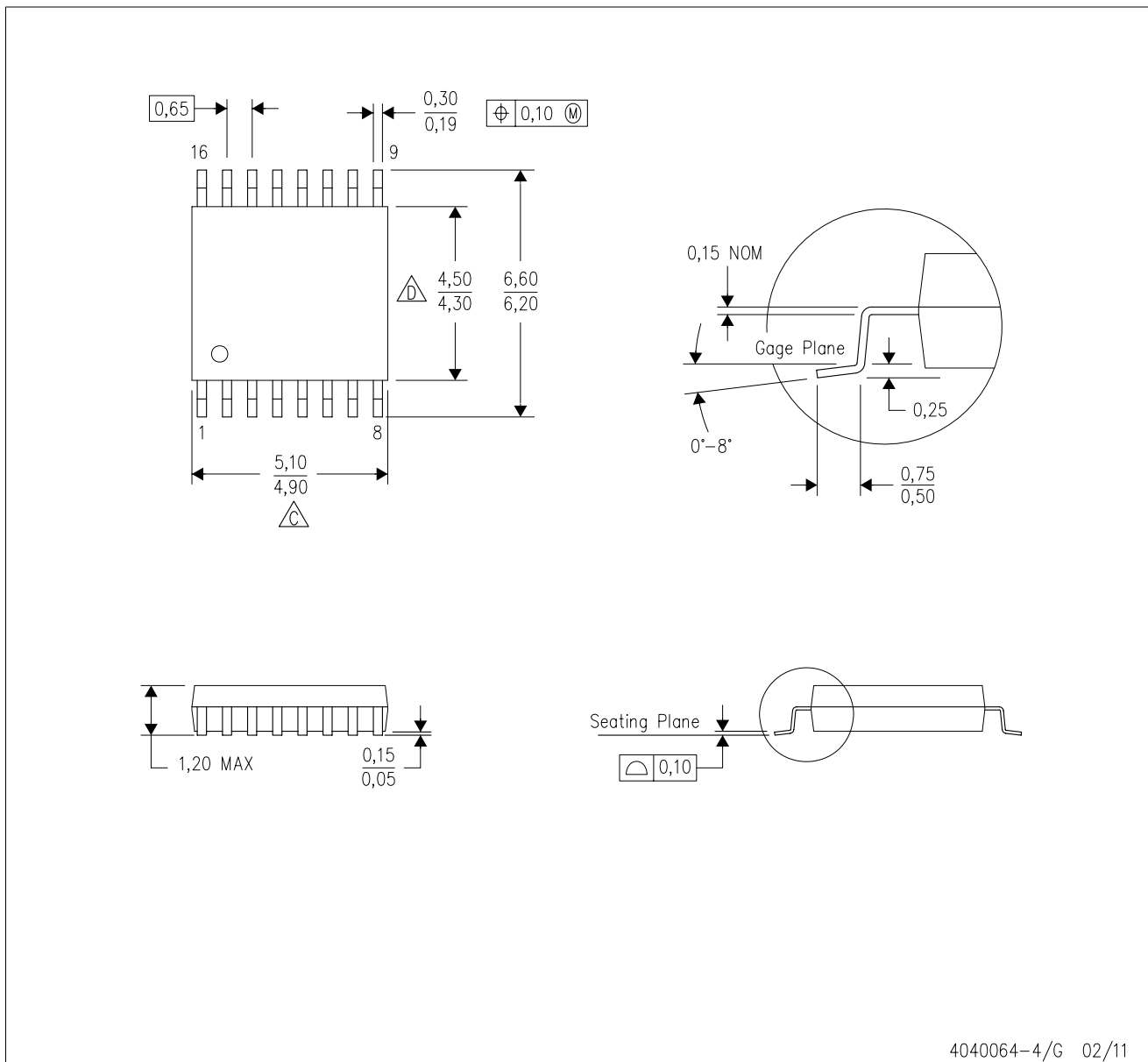

4040064-4/G 02/11

- NOTES:
- A. All linear dimensions are in millimeters. Dimensioning and tolerancing per ASME Y14.5M-1994.
 - B. This drawing is subject to change without notice.
 - C. Body length does not include mold flash, protrusions, or gate burrs. Mold flash, protrusions, or gate burrs shall not exceed 0,15 each side.
 - D. Body width does not include interlead flash. Interlead flash shall not exceed 0,25 each side.
 - E. Falls within JEDEC MO-153

IMPORTANT NOTICE

Texas Instruments Incorporated (TI) reserves the right to make corrections, enhancements, improvements and other changes to its semiconductor products and services per JESD46, latest issue, and to discontinue any product or service per JESD48, latest issue. Buyers should obtain the latest relevant information before placing orders and should verify that such information is current and complete.

TI's published terms of sale for semiconductor products (<http://www.ti.com/sc/docs/stdterms.htm>) apply to the sale of packaged integrated circuit products that TI has qualified and released to market. Additional terms may apply to the use or sale of other types of TI products and services.

Reproduction of significant portions of TI information in TI data sheets is permissible only if reproduction is without alteration and is accompanied by all associated warranties, conditions, limitations, and notices. TI is not responsible or liable for such reproduced documentation. Information of third parties may be subject to additional restrictions. Resale of TI products or services with statements different from or beyond the parameters stated by TI for that product or service voids all express and any implied warranties for the associated TI product or service and is an unfair and deceptive business practice. TI is not responsible or liable for any such statements.

Buyers and others who are developing systems that incorporate TI products (collectively, "Designers") understand and agree that Designers remain responsible for using their independent analysis, evaluation and judgment in designing their applications and that Designers have full and exclusive responsibility to assure the safety of Designers' applications and compliance of their applications (and of all TI products used in or for Designers' applications) with all applicable regulations, laws and other applicable requirements. Designer represents that, with respect to their applications, Designer has all the necessary expertise to create and implement safeguards that (1) anticipate dangerous consequences of failures, (2) monitor failures and their consequences, and (3) lessen the likelihood of failures that might cause harm and take appropriate actions. Designer agrees that prior to using or distributing any applications that include TI products, Designer will thoroughly test such applications and the functionality of such TI products as used in such applications.

TI's provision of technical, application or other design advice, quality characterization, reliability data or other services or information, including, but not limited to, reference designs and materials relating to evaluation modules, (collectively, "TI Resources") are intended to assist designers who are developing applications that incorporate TI products; by downloading, accessing or using TI Resources in any way, Designer (individually or, if Designer is acting on behalf of a company, Designer's company) agrees to use any particular TI Resource solely for this purpose and subject to the terms of this Notice.

TI's provision of TI Resources does not expand or otherwise alter TI's applicable published warranties or warranty disclaimers for TI products, and no additional obligations or liabilities arise from TI providing such TI Resources. TI reserves the right to make corrections, enhancements, improvements and other changes to its TI Resources. TI has not conducted any testing other than that specifically described in the published documentation for a particular TI Resource.

Designer is authorized to use, copy and modify any individual TI Resource only in connection with the development of applications that include the TI product(s) identified in such TI Resource. NO OTHER LICENSE, EXPRESS OR IMPLIED, BY ESTOPPEL OR OTHERWISE TO ANY OTHER TI INTELLECTUAL PROPERTY RIGHT, AND NO LICENSE TO ANY TECHNOLOGY OR INTELLECTUAL PROPERTY RIGHT OF TI OR ANY THIRD PARTY IS GRANTED HEREIN, including but not limited to any patent right, copyright, mask work right, or other intellectual property right relating to any combination, machine, or process in which TI products or services are used. Information regarding or referencing third-party products or services does not constitute a license to use such products or services, or a warranty or endorsement thereof. Use of TI Resources may require a license from a third party under the patents or other intellectual property of the third party, or a license from TI under the patents or other intellectual property of TI.

TI RESOURCES ARE PROVIDED "AS IS" AND WITH ALL FAULTS. TI DISCLAIMS ALL OTHER WARRANTIES OR REPRESENTATIONS, EXPRESS OR IMPLIED, REGARDING RESOURCES OR USE THEREOF, INCLUDING BUT NOT LIMITED TO ACCURACY OR COMPLETENESS, TITLE, ANY EPIDEMIC FAILURE WARRANTY AND ANY IMPLIED WARRANTIES OF MERCHANTABILITY, FITNESS FOR A PARTICULAR PURPOSE, AND NON-INFRINGEMENT OF ANY THIRD PARTY INTELLECTUAL PROPERTY RIGHTS. TI SHALL NOT BE LIABLE FOR AND SHALL NOT DEFEND OR INDEMNIFY DESIGNER AGAINST ANY CLAIM, INCLUDING BUT NOT LIMITED TO ANY INFRINGEMENT CLAIM THAT RELATES TO OR IS BASED ON ANY COMBINATION OF PRODUCTS EVEN IF DESCRIBED IN TI RESOURCES OR OTHERWISE. IN NO EVENT SHALL TI BE LIABLE FOR ANY ACTUAL, DIRECT, SPECIAL, COLLATERAL, INDIRECT, PUNITIVE, INCIDENTAL, CONSEQUENTIAL OR EXEMPLARY DAMAGES IN CONNECTION WITH OR ARISING OUT OF TI RESOURCES OR USE THEREOF, AND REGARDLESS OF WHETHER TI HAS BEEN ADVISED OF THE POSSIBILITY OF SUCH DAMAGES.

Unless TI has explicitly designated an individual product as meeting the requirements of a particular industry standard (e.g., ISO/TS 16949 and ISO 26262), TI is not responsible for any failure to meet such industry standard requirements.

Where TI specifically promotes products as facilitating functional safety or as compliant with industry functional safety standards, such products are intended to help enable customers to design and create their own applications that meet applicable functional safety standards and requirements. Using products in an application does not by itself establish any safety features in the application. Designers must ensure compliance with safety-related requirements and standards applicable to their applications. Designer may not use any TI products in life-critical medical equipment unless authorized officers of the parties have executed a special contract specifically governing such use. Life-critical medical equipment is medical equipment where failure of such equipment would cause serious bodily injury or death (e.g., life support, pacemakers, defibrillators, heart pumps, neurostimulators, and implantables). Such equipment includes, without limitation, all medical devices identified by the U.S. Food and Drug Administration as Class III devices and equivalent classifications outside the U.S.

TI may expressly designate certain products as completing a particular qualification (e.g., Q100, Military Grade, or Enhanced Product). Designers agree that it has the necessary expertise to select the product with the appropriate qualification designation for their applications and that proper product selection is at Designers' own risk. Designers are solely responsible for compliance with all legal and regulatory requirements in connection with such selection.

Designer will fully indemnify TI and its representatives against any damages, costs, losses, and/or liabilities arising out of Designer's non-compliance with the terms and provisions of this Notice.