

TPD2E2U06 Dual-Channel High-Speed ESD Protection Device

1 Features

- IEC 61000-4-2 Level 4
 - ± 25 kV (Contact Discharge)
 - ± 30 kV (Air-gap Discharge)
- IEC 61000-4-5 Surge Protection
 - 5.5 A Peak Pulse Current (8/20 μ s Pulse)
- IO Capacitance 1.5 pF (Typ)
- DC Breakdown Voltage 6.5 V (Min)
- Ultra-Low Leakage Current 10 nA (Max)
- Low ESD Clamping Voltage
- Industrial Temperature Range: -40°C to $+125^{\circ}\text{C}$
- Small Easy-to-Route DRL Package

2 Applications

- End Equipment
 - Set Top Box
 - Notebook
 - Server
 - Electronic Point of Sale (EPOS)
- Interfaces
 - USB 2.0
 - Ethernet
 - MIPI Bus
 - LVDS
 - I2C

3 Description

The TPD2E2U06 is a dual-channel low capacitance TVS diode ESD protection device. The device offers ± 25 -kV contact and ± 30 -kV air-gap ESD protection in accordance with the IEC 61000-4-2 standard. The 1.5-pF line capacitance of the TPD2E2U06 makes the device suitable for a wide range of applications. Typical application interfaces are USB 2.0, LVDS, and I²C™.

Device Information⁽¹⁾

| PART NUMBER | PACKAGE | BODY SIZE (NOM) |
|-------------|---------|-------------------|
| TPD2E2U06 | SOT (5) | 1.60 mm x 1.20 mm |

(1) For all available packages, see the orderable addendum at the end of the data sheet.

4 Simplified Schematic

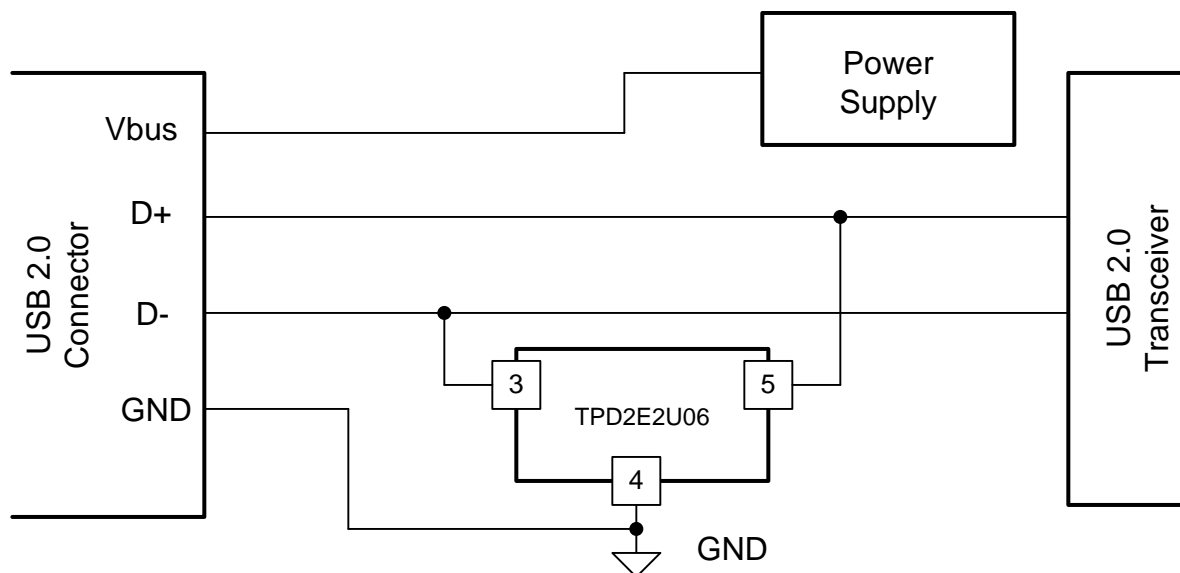

Table of Contents

| | | | |
|--|----------|--|-----------|
| 1 Features | 1 | 8.2 Functional Block Diagram | 7 |
| 2 Applications | 1 | 8.3 Feature Description | 7 |
| 3 Description | 1 | 8.4 Device Functional Modes | 8 |
| 4 Simplified Schematic | 1 | 9 Application and Implementation | 9 |
| 5 Revision History | 2 | 9.1 Application Information | 9 |
| 6 Pin Configuration and Functions | 3 | 9.2 Typical Application | 9 |
| 7 Specifications | 3 | 10 Power Supply Recommendations | 10 |
| 7.1 Absolute Maximum Ratings | 3 | 11 Layout | 10 |
| 7.2 ESD Ratings | 3 | 11.1 Layout Guidelines | 10 |
| 7.3 Recommended Operating Conditions | 3 | 11.2 Layout Example | 11 |
| 7.4 Thermal Information | 4 | 12 Device and Documentation Support | 11 |
| 7.5 Electrical Characteristics | 4 | 12.1 Trademarks | 11 |
| 7.6 Typical Characteristics | 5 | 12.2 Electrostatic Discharge Caution | 11 |
| 8 Detailed Description | 7 | 12.3 Glossary | 11 |
| 8.1 Overview | 7 | 13 Mechanical, Packaging, and Orderable Information | 11 |

5 Revision History

Changes from Revision A (June 2013) to Revision B

Page

- Added ESD Ratings table, Feature Description section, Device Functional Modes, Application and Implementation section, Power Supply Recommendations section, Layout section, Device and Documentation Support section, and Mechanical, Packaging, and Orderable Information section. **1**

6 Pin Configuration and Functions

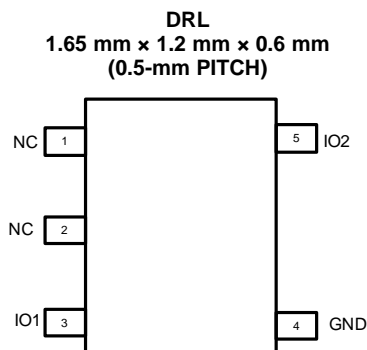

Pin Functions

| PIN | | I/O | DESCRIPTION |
|------|------|-----|---|
| NAME | NO. | | |
| IO1 | 3 | I/O | The IO1 and IO2 pins are an ESD protected channel. Connect these pins to the data line as close to the connector as possible. |
| IO2 | 5 | I/O | |
| NC | 1, 2 | - | This pin is not connected and is left floating, grounded, or connected to VCC. |
| GND | 4 | G | The GND (ground) pin is connected to ground. |

7 Specifications

7.1 Absolute Maximum Ratings

over operating free-air temperature range (unless otherwise noted)

| | MIN | MAX | UNIT |
|---|-----|--------------------|------|
| I_{PP} Peak pulse current (tp = 8/20 μ s) | | 5.5 ⁽¹⁾ | A |
| P_{PP} Peak pulse power (tp = 8/20 μ s) | | 85 ⁽¹⁾ | W |
| Operating temperature | -40 | 125 | °C |
| Storage temperature | -65 | 155 | °C |

(1) Measured at 25°C.

7.2 ESD Ratings

| | | VALUE | UNIT |
|-------------------------------------|--|--------|------|
| $V_{(ESD)}$ Electrostatic discharge | Human-body model (HBM), per ANSI/ESDA/JEDEC JS-001 ⁽¹⁾ | ±4000 | V |
| | Charged-device model (CDM), per JEDEC specification JESD22-C101 ⁽²⁾ | ±1500 | |
| | EC 61000-4-2 contact | ±25000 | |
| | EC 61000-4-2 air-gap | ±30000 | |

(1) JEDEC document JEP155 states that 500-V HBM allows safe manufacturing with a standard ESD control process. Manufacturing with less than 500-V HBM is possible with the necessary precautions.

(2) JEDEC document JEP157 states that 250-V CDM allows safe manufacturing with a standard ESD control process. Manufacturing with less than 250-V CDM is possible with the necessary precautions.

7.3 Recommended Operating Conditions

over operating free-air temperature range (unless otherwise noted)

| | | MIN | NOM | MAX | UNIT |
|----------|--------------------------------|-----|-----|-----|------|
| V_{IO} | Input Pin Voltage | 0 | | 5.5 | V |
| T_A | Operating Free Air Temperature | -40 | | 125 | °C |

7.4 Thermal Information

| THERMAL METRIC ⁽¹⁾ | | TPD2E2U06 | | UNIT |
|-------------------------------|--|-----------|--|------|
| | | DRL | | |
| | | 5 PINS | | |
| R _{θJA} | Junction-to-ambient thermal resistance | 286.8 | | °C/W |
| R _{θJC(top)} | Junction-to-case (top) thermal resistance | 130.7 | | |
| R _{θJB} | Junction-to-board thermal resistance | 104.8 | | |
| ψ _{JT} | Junction-to-top characterization parameter | 25.6 | | |
| ψ _{JB} | Junction-to-board characterization parameter | 104.3 | | |

(1) For more information about traditional and new thermal metrics, see the *IC Package Thermal Metrics* application report, [SPRA953](http://www.ti.com/lit/zip/Spra953).

7.5 Electrical Characteristics

over operating free-air temperature range (unless otherwise noted)

| PARAMETER | | TEST CONDITIONS | MIN | TYP | MAX | UNIT |
|-------------------------|--|---|-----|------|------|------|
| V _{RWM} | Reverse stand-off voltage | I _{IO} < 10 μA | | | 5.5 | V |
| V _{CLAMP} | IO to GND | I _{PP} = 1 A, TLP ⁽¹⁾ | | 9.7 | | V |
| | | I _{PP} = 5 A, TLP ⁽¹⁾ | | 12.4 | | |
| V _{CLAMP} | GND to IO | I _{PP} = 1 A, TLP ⁽¹⁾ | | 1.9 | | V |
| | | I _{PP} = 5 A, TLP ⁽¹⁾ | | 4 | | |
| R _{DYN} | Dynamic resistance | IO to GND ⁽²⁾ | | 0.5 | | Ω |
| R _{DYN} | Dynamic resistance | GND to IO ⁽²⁾ | | 0.25 | | Ω |
| CL | Line capacitance | f = 1 MHz, V _{BIAS} = 2.5 V ⁽³⁾ | | 1.5 | 1.9 | pF |
| C _{CROSS} | Channel-to-channel input capacitance | Pin 4 = 0 V, f = 1 MHz, V _{BIAS} = 2.5 V, between channel pins ⁽³⁾ | | 0.02 | 0.03 | pF |
| ΔC _{IO-TO-GND} | Variation of channel input capacitance | Pin 4 = 0 V, f = 1 MHz, V _{BIAS} = 2.5 V, channel_x pin to GND – channel_y pin to GND ⁽³⁾ | | 0.03 | 0.1 | pF |
| V _{BR} | Break-down voltage | I _{IO} = 1 mA | 6.5 | | 8.5 | V |
| I _{LEAK} | Leakage current | V _{IO} = 2.5 V | | 1 | 10 | nA |

(1) Transmission Line Pulse with 10-ns rise time, 100-ns width.

(2) Extraction of R_{DYN} Using least squares fit of TLP characteristics between I = 20 A and I = 30 A.

(3) Measured at 25°C.

7.6 Typical Characteristics

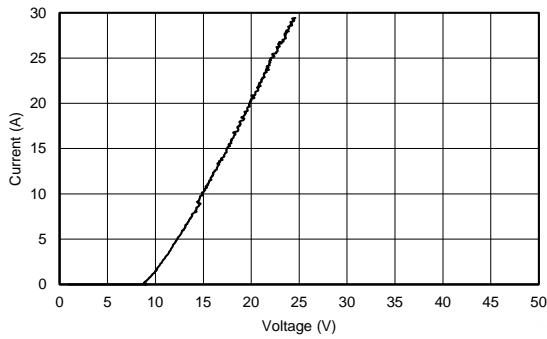

Figure 1. TLP, Data to GND

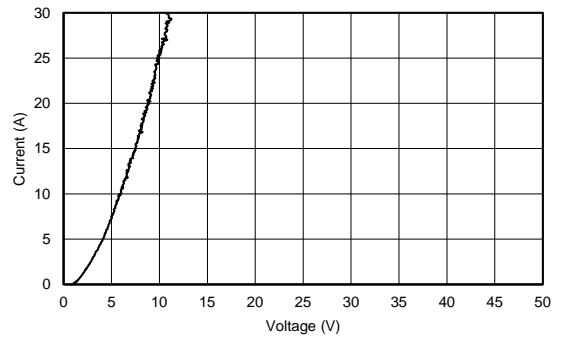

Figure 2. TLP, GND to Data

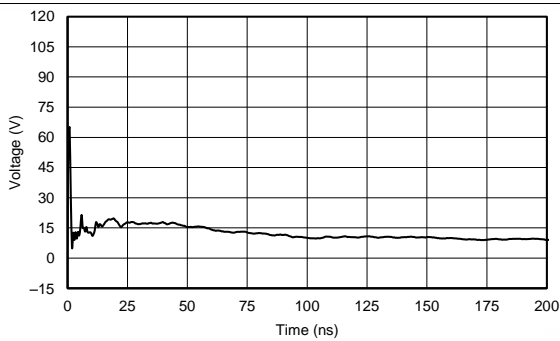

Figure 3. IEC 61000-4-2 Clamping Voltage, +8 kV Contact

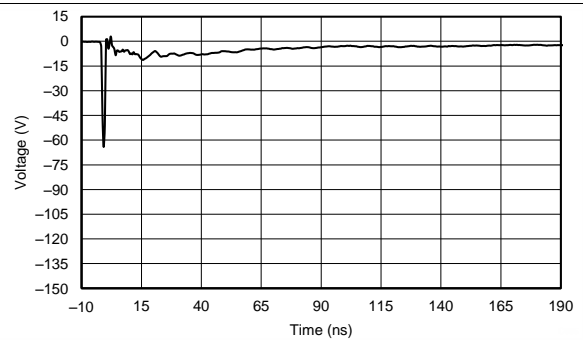
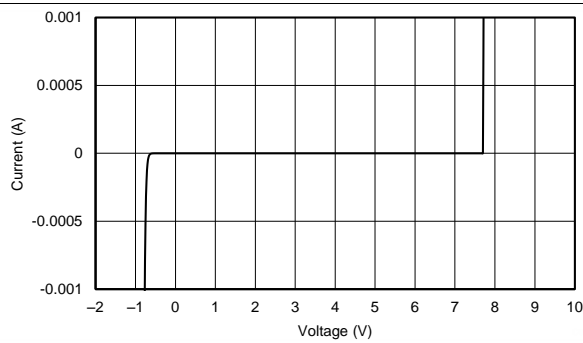
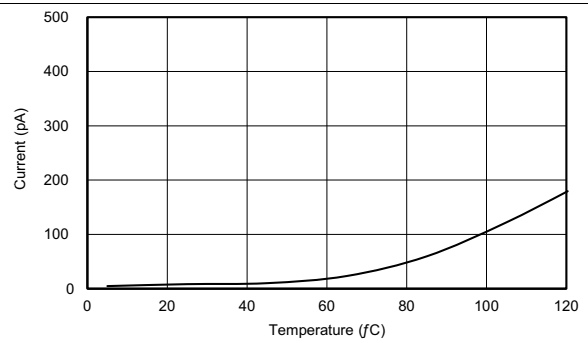

Figure 4. IEC 61000-4-2 Clamping Voltage, -8 kV Contact



$T_A = 25^\circ\text{C}$

Figure 5. IV Curve



$V_{IN} 2.5\text{ V}$

Figure 6. I_{LEAK} vs Temperature

Typical Characteristics (continued)

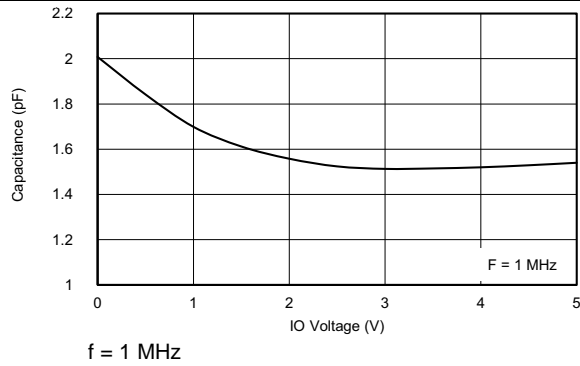

Figure 7. Capacitance Across V_{BIAS}

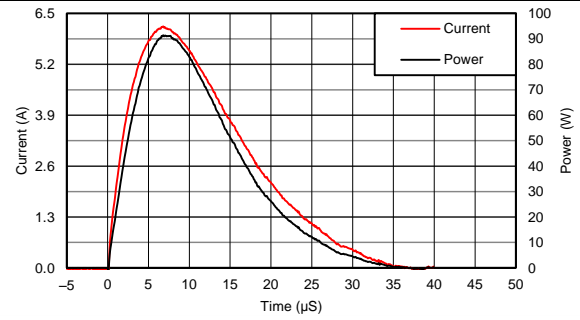

Figure 8. Surge Curve (tp = 8/20 μs) IO to GND

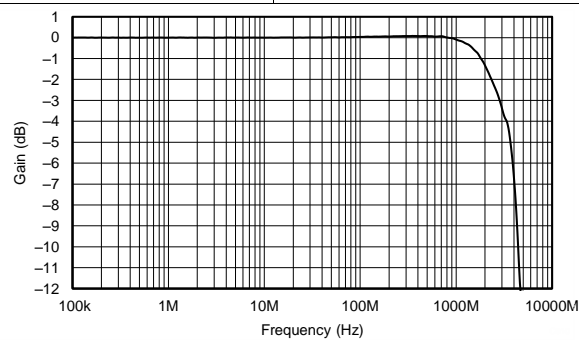

Figure 9. Insertion Loss

8 Detailed Description

8.1 Overview

The TPD2E2U06 is a dual-channel low capacitance TVS diode ESD protection device. The device offers ± 25 -kV contact and ± 30 -kV air-gap ESD protection in accordance with the IEC 61000-4-2 standard. The 1.5-pF line capacitance of the TPD2E2U06 makes the device suitable for a wide range of applications. Typical application interfaces are USB 2.0, LVDS, and I2C.

8.2 Functional Block Diagram

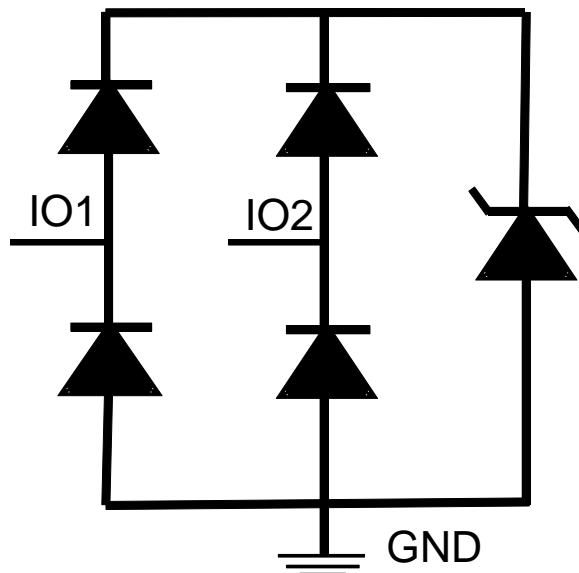

8.3 Feature Description

The TPD2E2U06 is a dual-channel low capacitance TVS diode ESD protection device. The device offers ± 25 -kV contact and ± 30 -kV air-gap ESD protection in accordance with the IEC 61000-4-2 standard. The 1.5-pF line capacitance of the TPD2E2U06 makes the device suitable for a wide range of applications. Typical application interfaces are USB 2.0, LVDS, and I2C.

8.3.1 IEC 61000-4-2 Level 4

The I/O pins can withstand ESD events up to ± 25 -kV contact and ± 30 -kV air. An ESD/surge clamp diverts the current to ground.

8.3.2 IO Capacitance

The capacitance between each I/O pin to ground is 1.5 pF. These capacitances support data rates in excess of 1.5 Gbps.

8.3.3 DC Breakdown Voltage

The DC breakdown voltage of each I/O pin is a minimum of 6.5 V. This ensures that sensitive equipment is protected from surges above the reverse standoff voltage of 5.5 V.

8.3.4 Ultra-Low Leakage Current

The I/O pins feature an ultra-low leakage current of 10 nA (Max) with a bias of 2.5 V.

8.3.5 Low ESD Clamping Voltage

The I/O pins feature an ESD clamp that is capable of clamping the voltage to 9.7 V ($I_{PP} = 1$ A).

Feature Description (continued)

8.3.6 Industrial Temperature Range

This device is designed to operate from -40°C to 125°C .

8.3.7 Small Easy-to-Route Package

The layout of this device makes it simple and easy to add protection to an existing layout. The packages offers flow-through routing, requiring minimal modification to an existing layout.

8.4 Device Functional Modes

TPD2E2U06 is a passive integrated circuit that triggers when voltages are above V_{BR} or below the lower diodes V_f (-0.6 V). During ESD events, voltages as high as $\pm 30\text{ kV}$ (air) can be directed to ground via the internal diode network. Once the voltages on the protected line fall below the trigger levels of TPD2E2U06 (usually within 10's of nano-seconds) the device reverts to passive.

9 Application and Implementation

NOTE

Information in the following applications sections is not part of the TI component specification, and TI does not warrant its accuracy or completeness. TI's customers are responsible for determining suitability of components for their purposes. Customers should validate and test their design implementation to confirm system functionality.

9.1 Application Information

TPD2E2U06 is a diode type TVS which is typically used to provide a path to ground for dissipating ESD events on hi-speed signal lines between a human interface connector and a system. As the current from ESD passes through the TVS, only a small voltage drop is present across the diode. This is the voltage presented to the protected IC. The low R_{DYN} of the triggered TVS holds this voltage, V_{CLAMP} , to a safe level for the protected IC.

9.2 Typical Application

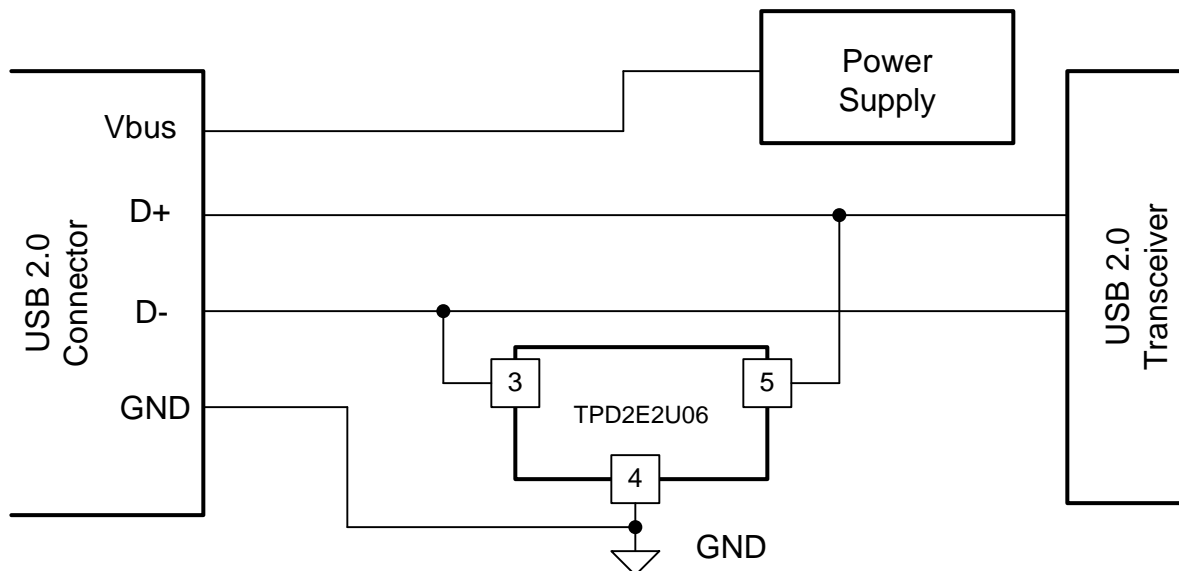

Figure 10. Typical USB Application Diagram

9.2.1 Design Requirements

For this design example, one TPD2E2U06 device will be used in a USB 2.0 application. This will provide complete port protection.

Given the USB 2.0 application, the following parameters are known.

| DESIGN PARAMETER | VALUE |
|-----------------------------|--------------|
| Signal range on Pins 3 or 5 | 0 V to 3.3 V |
| Operating Frequency | 240 MHz |

9.2.2 Detailed Design Procedure

To begin the design process, some parameters must be decided upon; the designer needs to know the following:

- Signal range of all the protected lines
- Operating frequency

9.2.2.1 Signal Range

The TPD2E2U06 has 2 identical protection channels for signal lines. The symmetry of the device provides flexibility when selecting which of the 2 I/O channels will protect which signal lines. Any I/O will support a signal range of 0 to 5.5 V.

9.2.2.2 Operating Frequency

The TPD2E2U06 has a capacitance of 1.5 pF (Typ), supporting USB 2.0 data rates.

9.2.3 Application Curves

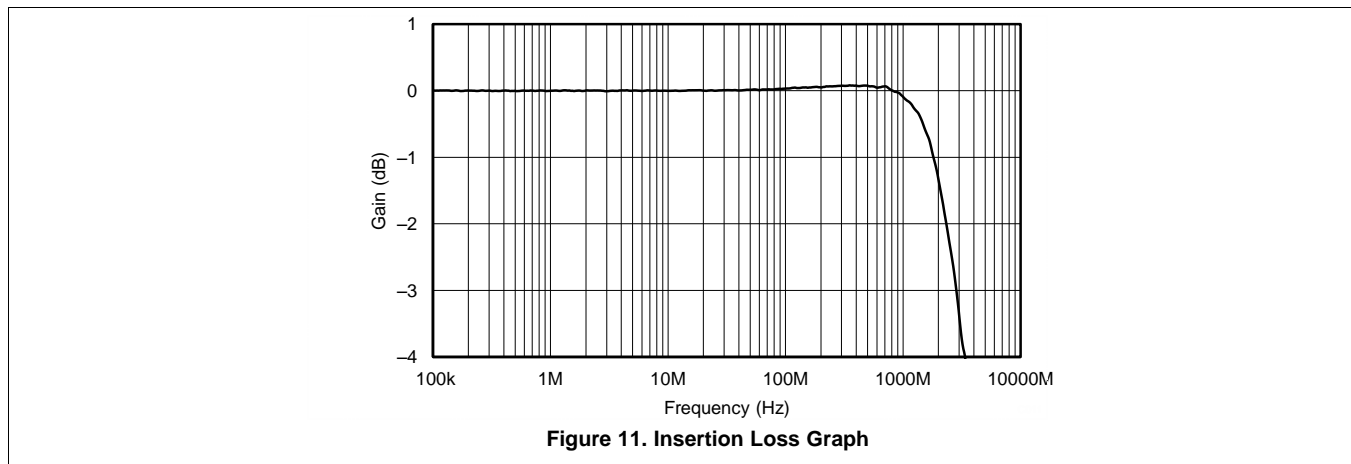

10 Power Supply Recommendations

This device is a passive ESD protection device and there is no need to power it. Care should be taken to make sure that the maximum voltage specifications for each line are not violated.

11 Layout

11.1 Layout Guidelines

- The optimum placement is as close to the connector as possible.
 - EMI during an ESD event can couple from the trace being struck to other nearby unprotected traces, resulting in early system failures.
 - The PCB designer needs to minimize the possibility of EMI coupling by keeping any unprotected traces away from the protected traces which are between the TVS and the connector.
- Route the protected traces as straight as possible.
- Eliminate any sharp corners on the protected traces between the TVS and the connector by using rounded corners with the largest radii possible.
 - Electric fields tend to build up on corners, increasing EMI coupling.

11.2 Layout Example

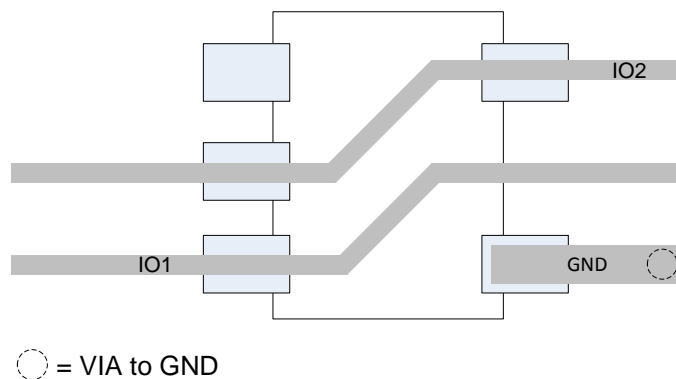

Figure 12. Routing with DRL Package

12 Device and Documentation Support

12.1 Trademarks

I²C is a trademark of NXP Semiconductors.
All other trademarks are the property of their respective owners.

12.2 Electrostatic Discharge Caution



These devices have limited built-in ESD protection. The leads should be shorted together or the device placed in conductive foam during storage or handling to prevent electrostatic damage to the MOS gates.

12.3 Glossary

[SLYZ022](#) — *TI Glossary*.

This glossary lists and explains terms, acronyms, and definitions.

13 Mechanical, Packaging, and Orderable Information

The following pages include mechanical, packaging, and orderable information. This information is the most current data available for the designated devices. This data is subject to change without notice and revision of this document. For browser-based versions of this data sheet, refer to the left-hand navigation.

PACKAGING INFORMATION

| Orderable Device | Status (1) | Package Type | Package Drawing | Pins | Package Qty | Eco Plan (2) | Lead/Ball Finish (6) | MSL Peak Temp (3) | Op Temp (°C) | Device Marking (4/5) | Samples |
|------------------|---------------|--------------|-----------------|------|-------------|-------------------------|-------------------------|----------------------|--------------|-------------------------|---------|
| TPD2E2U06DRLR | ACTIVE | SOT-5X3 | DRL | 5 | 4000 | Green (RoHS & no Sb/Br) | CU NIPDAU | Level-1-260C-UNLIM | -40 to 125 | DT | Samples |

(1) The marketing status values are defined as follows:

ACTIVE: Product device recommended for new designs.

LIFEBUY: TI has announced that the device will be discontinued, and a lifetime-buy period is in effect.

NRND: Not recommended for new designs. Device is in production to support existing customers, but TI does not recommend using this part in a new design.

PREVIEW: Device has been announced but is not in production. Samples may or may not be available.

OBSELETE: TI has discontinued the production of the device.

(2) **RoHS:** TI defines "RoHS" to mean semiconductor products that are compliant with the current EU RoHS requirements for all 10 RoHS substances, including the requirement that RoHS substance do not exceed 0.1% by weight in homogeneous materials. Where designed to be soldered at high temperatures, "RoHS" products are suitable for use in specified lead-free processes. TI may reference these types of products as "Pb-Free".

RoHS Exempt: TI defines "RoHS Exempt" to mean products that contain lead but are compliant with EU RoHS pursuant to a specific EU RoHS exemption.

Green: TI defines "Green" to mean the content of Chlorine (Cl) and Bromine (Br) based flame retardants meet JS709B low halogen requirements of <=1000ppm threshold. Antimony trioxide based flame retardants must also meet the <=1000ppm threshold requirement.

(3) MSL, Peak Temp. - The Moisture Sensitivity Level rating according to the JEDEC industry standard classifications, and peak solder temperature.

(4) There may be additional marking, which relates to the logo, the lot trace code information, or the environmental category on the device.

(5) Multiple Device Markings will be inside parentheses. Only one Device Marking contained in parentheses and separated by a "~" will appear on a device. If a line is indented then it is a continuation of the previous line and the two combined represent the entire Device Marking for that device.

(6) Lead/Ball Finish - Orderable Devices may have multiple material finish options. Finish options are separated by a vertical ruled line. Lead/Ball Finish values may wrap to two lines if the finish value exceeds the maximum column width.

Important Information and Disclaimer:The information provided on this page represents TI's knowledge and belief as of the date that it is provided. TI bases its knowledge and belief on information provided by third parties, and makes no representation or warranty as to the accuracy of such information. Efforts are underway to better integrate information from third parties. TI has taken and continues to take reasonable steps to provide representative and accurate information but may not have conducted destructive testing or chemical analysis on incoming materials and chemicals. TI and TI suppliers consider certain information to be proprietary, and thus CAS numbers and other limited information may not be available for release.

In no event shall TI's liability arising out of such information exceed the total purchase price of the TI part(s) at issue in this document sold by TI to Customer on an annual basis.

OTHER QUALIFIED VERSIONS OF TPD2E2U06 :

- Automotive: [TPD2E2U06-Q1](#)

NOTE: Qualified Version Definitions:

- Automotive - Q100 devices qualified for high-reliability automotive applications targeting zero defects

TAPE AND REEL INFORMATION



QUADRANT ASSIGNMENTS FOR PIN 1 ORIENTATION IN TAPE



*All dimensions are nominal

| Device | Package Type | Package Drawing | Pins | SPQ | Reel Diameter (mm) | Reel Width W1 (mm) | A0 (mm) | B0 (mm) | K0 (mm) | P1 (mm) | W (mm) | Pin1 Quadrant |
|---------------|--------------|-----------------|------|------|--------------------|--------------------|---------|---------|---------|---------|--------|---------------|
| TPD2E2U06DRLR | SOT-5X3 | DRL | 5 | 4000 | 180.0 | 8.4 | 1.98 | 1.78 | 0.69 | 4.0 | 8.0 | Q3 |

TAPE AND REEL BOX DIMENSIONS



*All dimensions are nominal

| Device | Package Type | Package Drawing | Pins | SPQ | Length (mm) | Width (mm) | Height (mm) |
|---------------|--------------|-----------------|------|------|-------------|------------|-------------|
| TPD2E2U06DRLR | SOT-5X3 | DRL | 5 | 4000 | 183.0 | 183.0 | 20.0 |



- NOTES:
- A. All linear dimensions are in millimeters. Dimensioning and tolerancing per ASME Y14.5M-1994.
 - B. This drawing is subject to change without notice.
 - C. Body dimensions do not include mold flash, interlead flash, protrusions, or gate burrs. Mold flash, interlead flash, protrusions, or gate burrs shall not exceed 0,15 per end or side.
 - D. JEDEC package registration is pending.

IMPORTANT NOTICE

Texas Instruments Incorporated (TI) reserves the right to make corrections, enhancements, improvements and other changes to its semiconductor products and services per JESD46, latest issue, and to discontinue any product or service per JESD48, latest issue. Buyers should obtain the latest relevant information before placing orders and should verify that such information is current and complete.

TI's published terms of sale for semiconductor products (<http://www.ti.com/sc/docs/stdterms.htm>) apply to the sale of packaged integrated circuit products that TI has qualified and released to market. Additional terms may apply to the use or sale of other types of TI products and services.

Reproduction of significant portions of TI information in TI data sheets is permissible only if reproduction is without alteration and is accompanied by all associated warranties, conditions, limitations, and notices. TI is not responsible or liable for such reproduced documentation. Information of third parties may be subject to additional restrictions. Resale of TI products or services with statements different from or beyond the parameters stated by TI for that product or service voids all express and any implied warranties for the associated TI product or service and is an unfair and deceptive business practice. TI is not responsible or liable for any such statements.

Buyers and others who are developing systems that incorporate TI products (collectively, "Designers") understand and agree that Designers remain responsible for using their independent analysis, evaluation and judgment in designing their applications and that Designers have full and exclusive responsibility to assure the safety of Designers' applications and compliance of their applications (and of all TI products used in or for Designers' applications) with all applicable regulations, laws and other applicable requirements. Designer represents that, with respect to their applications, Designer has all the necessary expertise to create and implement safeguards that (1) anticipate dangerous consequences of failures, (2) monitor failures and their consequences, and (3) lessen the likelihood of failures that might cause harm and take appropriate actions. Designer agrees that prior to using or distributing any applications that include TI products, Designer will thoroughly test such applications and the functionality of such TI products as used in such applications.

TI's provision of technical, application or other design advice, quality characterization, reliability data or other services or information, including, but not limited to, reference designs and materials relating to evaluation modules, (collectively, "TI Resources") are intended to assist designers who are developing applications that incorporate TI products; by downloading, accessing or using TI Resources in any way, Designer (individually or, if Designer is acting on behalf of a company, Designer's company) agrees to use any particular TI Resource solely for this purpose and subject to the terms of this Notice.

TI's provision of TI Resources does not expand or otherwise alter TI's applicable published warranties or warranty disclaimers for TI products, and no additional obligations or liabilities arise from TI providing such TI Resources. TI reserves the right to make corrections, enhancements, improvements and other changes to its TI Resources. TI has not conducted any testing other than that specifically described in the published documentation for a particular TI Resource.

Designer is authorized to use, copy and modify any individual TI Resource only in connection with the development of applications that include the TI product(s) identified in such TI Resource. NO OTHER LICENSE, EXPRESS OR IMPLIED, BY ESTOPPEL OR OTHERWISE TO ANY OTHER TI INTELLECTUAL PROPERTY RIGHT, AND NO LICENSE TO ANY TECHNOLOGY OR INTELLECTUAL PROPERTY RIGHT OF TI OR ANY THIRD PARTY IS GRANTED HEREIN, including but not limited to any patent right, copyright, mask work right, or other intellectual property right relating to any combination, machine, or process in which TI products or services are used. Information regarding or referencing third-party products or services does not constitute a license to use such products or services, or a warranty or endorsement thereof. Use of TI Resources may require a license from a third party under the patents or other intellectual property of the third party, or a license from TI under the patents or other intellectual property of TI.

TI RESOURCES ARE PROVIDED "AS IS" AND WITH ALL FAULTS. TI DISCLAIMS ALL OTHER WARRANTIES OR REPRESENTATIONS, EXPRESS OR IMPLIED, REGARDING RESOURCES OR USE THEREOF, INCLUDING BUT NOT LIMITED TO ACCURACY OR COMPLETENESS, TITLE, ANY EPIDEMIC FAILURE WARRANTY AND ANY IMPLIED WARRANTIES OF MERCHANTABILITY, FITNESS FOR A PARTICULAR PURPOSE, AND NON-INFRINGEMENT OF ANY THIRD PARTY INTELLECTUAL PROPERTY RIGHTS. TI SHALL NOT BE LIABLE FOR AND SHALL NOT DEFEND OR INDEMNIFY DESIGNER AGAINST ANY CLAIM, INCLUDING BUT NOT LIMITED TO ANY INFRINGEMENT CLAIM THAT RELATES TO OR IS BASED ON ANY COMBINATION OF PRODUCTS EVEN IF DESCRIBED IN TI RESOURCES OR OTHERWISE. IN NO EVENT SHALL TI BE LIABLE FOR ANY ACTUAL, DIRECT, SPECIAL, COLLATERAL, INDIRECT, PUNITIVE, INCIDENTAL, CONSEQUENTIAL OR EXEMPLARY DAMAGES IN CONNECTION WITH OR ARISING OUT OF TI RESOURCES OR USE THEREOF, AND REGARDLESS OF WHETHER TI HAS BEEN ADVISED OF THE POSSIBILITY OF SUCH DAMAGES.

Unless TI has explicitly designated an individual product as meeting the requirements of a particular industry standard (e.g., ISO/TS 16949 and ISO 26262), TI is not responsible for any failure to meet such industry standard requirements.

Where TI specifically promotes products as facilitating functional safety or as compliant with industry functional safety standards, such products are intended to help enable customers to design and create their own applications that meet applicable functional safety standards and requirements. Using products in an application does not by itself establish any safety features in the application. Designers must ensure compliance with safety-related requirements and standards applicable to their applications. Designer may not use any TI products in life-critical medical equipment unless authorized officers of the parties have executed a special contract specifically governing such use. Life-critical medical equipment is medical equipment where failure of such equipment would cause serious bodily injury or death (e.g., life support, pacemakers, defibrillators, heart pumps, neurostimulators, and implantables). Such equipment includes, without limitation, all medical devices identified by the U.S. Food and Drug Administration as Class III devices and equivalent classifications outside the U.S.

TI may expressly designate certain products as completing a particular qualification (e.g., Q100, Military Grade, or Enhanced Product). Designers agree that it has the necessary expertise to select the product with the appropriate qualification designation for their applications and that proper product selection is at Designers' own risk. Designers are solely responsible for compliance with all legal and regulatory requirements in connection with such selection.

Designer will fully indemnify TI and its representatives against any damages, costs, losses, and/or liabilities arising out of Designer's non-compliance with the terms and provisions of this Notice.