

TPS51312

SLUSB57 – SEPTEMBER 2012

www.ti.com



This integrated circuit can be damaged by ESD. Texas Instruments recommends that all integrated circuits be handled with appropriate precautions. Failure to observe proper handling and installation procedures can cause damage.

ESD damage can range from subtle performance degradation to complete device failure. Precision integrated circuits may be more susceptible to damage because very small parametric changes could cause the device not to meet its published specifications.

ORDERING INFORMATION⁽¹⁾

T _A	PACKAGE	ORDERABLE DEVICE NUMBER	PINS	OUTPUT SUPPLY	MINIMUM QUANTITY	ECO PLAN
-40°C to 85°C	Plastic SON (DRC)	TPS51312DRCR	10	Tape and reel	3000	Green (RoHS and no Pb/Br)
		TPS51312DRCT		Mini reel	250	

(1) For the most current package and ordering information see the Package Option Addendum at the end of this document, or see the TI web site at www.ti.com.

ABSOLUTE MAXIMUM RATINGS⁽¹⁾

		VALUE		UNIT
		MIN	MAX	
Input voltage range ⁽²⁾	VIN, VCC, EN	-0.3	6.0	V
	SW	-2.0	6.0	
	SW (transient 20 ns)	-3.0	8.5	
	FB	-1	3.6	
Output voltage range ⁽²⁾	PGOOD	-0.3	6.0	V
Junction temperature, T _J			125	°C
Storage temperature, T _{stg}		-55	150	°C

- (1) Stresses beyond those listed under "absolute maximum ratings" may cause permanent damage to the device. These are stress ratings only and functional operation of the device at these or any other conditions beyond those indicated under "recommended operating conditions" is not implied. Exposure to absolute-maximum-rated conditions for extended periods may affect device reliability.
- (2) All voltage values are with respect to the network ground terminal unless otherwise noted.

THERMAL INFORMATION

THERMAL METRIC ⁽¹⁾		TPS51312	UNITS
		DRC (10-PIN)	
θ _{JA}	Junction-to-ambient thermal resistance	42.4	°C/W
θ _{JCtop}	Junction-to-case (top) thermal resistance	53.9	
θ _{JB}	Junction-to-board thermal resistance	18.1	
ψ _{JT}	Junction-to-top characterization parameter	1.1	
ψ _{JB}	Junction-to-board characterization parameter	18.3	
θ _{JCbot}	Junction-to-case (bottom) thermal resistance	6.3	

(1) For more information about traditional and new thermal metrics, see the *IC Package Thermal Metrics* application report, [SPRA953](http://www.ti.com/lit/zip/spra953).

RECOMMENDED OPERATING CONDITIONS

		MIN	MAX	UNIT
Input voltage range	VIN, VCC, SW, EN	-0.1	5.5	V
	FB	-0.1	3.5	
Output voltage range	PGOOD	-0.1	5.5	V
Operating free-air temperature, T _A		-40	85	°C

ELECTRICAL CHARACTERISTICS

Over operating free-air temperature range, $V_{IN} = 5\text{ V}$, $V_{CC} = 5\text{ V}$, $V_{EN} = 3.3\text{ V}$ (unless otherwise noted).

PARAMETER		TEST CONDITION	MIN	TYP	MAX	UNIT
SUPPLY VOLTAGE						
V_{IN}	Supply voltage		3.1		5.5	V
V_{CC}	Supply voltage		3.1		5.5	V
SUPPLY CURRENT						
I_{IN}	Input voltage supply current	EN = High			100	μA
I_{SD}	Input voltage shutdown current	EN = Low			12	μA
$I_{VCC(in)}$	VCC supply current	EN = High		700		μA
$I_{VCC(sd)}$	VCC shutdown current	EN = Low, $T_A = 25^\circ\text{C}$			20	μA
VFB REFERENCE VOLTAGE						
V_{FBREF}	Reference voltage			0.6		V
$V_{FBREFTOL}$	Reference voltage tolerance	$T_A = 25^\circ\text{C}$	-1%		1%	
I_{FB}	Feedback pin leakage current		-100		100	nA
SMPS FREQUENCY						
f_{SW}	Switching frequency			0.9		MHz
$t_{OFF(min)}$	Minimum off-time		110	190	270	ns
t_{DEAD}	Dead time ⁽¹⁾	SW node high, $V_{IN} = 5\text{ V}$		9		ns
		SW node low, $V_{IN} = 5\text{ V}$		10		
LOGIC THRESHOLD AND CURRENT						
V_{LL}	EN low-level voltage				0.8	V
V_{LH}	EN high-level voltage		1.5			V
I_{LLK}	EN input leakage current	$V_{IN} = V_{CC} = 3.3\text{ V}$	-3	1	3	μA
MOSFET						
$R_{DS(on)_H}$	On-resistance ⁽¹⁾	$V_{IN} = 5\text{ V}$		81		m Ω
		$V_{IN} = 5\text{ V}$		41		
SOFT-START						
t_{SS}	Soft-start time ⁽¹⁾	V_{FB} rising from 0 V to 0.6 V		300		μs
PGOOD COMPARATOR						
V_{PGTH}	PGOOD threshold	PGOOD out to higher w/r/t V_{FB}		130%		
		PGOOD out to lower w/r/t V_{FB}		50%		
t_{PGDLY}	PGOOD high delay time	Delay for PGOOD in, after EN = Hi		1.3		ms
I_{PGLK}	PGOOD leakage current		-1	0	1	μA
PROTECTIONS						
I_{OCL}	Current limit threshold	Valley current limit, $V_{IN} = V_{CC} = 3.3\text{ V}$, $T_A = 25^\circ\text{C}$	4.8			A
V_{IN_UVLO}	VIN UVLO threshold voltage	Wake-up	2.85	2.95	3.05	V
		Shutdown	2.6	2.7	2.8	
V_{CC_UVLO}	VCC UVLO threshold voltage	Wake-up	2.85	2.95	3.05	V
		Shutdown	2.6	2.7	2.8	
V_{OVP}	OVP threshold voltage	OVP detect		130%		
t_{OVP}	OVP delay time	Overdrive = 100 mV		1.9		μs
V_{UVP}	UVP threshold voltage	UVP detect		50%		
t_{UVPDLY}	UVP delay time	Overdrive = 100 mV		2.4		μs

(1) Specified by design. Not production tested.

TPS51312

SLUSB57 – SEPTEMBER 2012

www.ti.com

ELECTRICAL CHARACTERISTICS (continued)

Over operating free-air temperature range, $V_{IN} = 5\text{ V}$, $V_{CC} = 5\text{ V}$, $V_{EN} = 3.3\text{ V}$ (unless otherwise noted).

PARAMETER	TEST CONDITION	MIN	TYP	MAX	UNIT
SW PULL-DOWN RESISTANCE					
R_{SWPD}	SW pull-down resistance	EN = Lo		260	Ω
THERMAL SHUTDOWN					
T_{SDN}	Thermal shutdown threshold ⁽²⁾	Shutdown temperature		145	$^{\circ}\text{C}$
		Hysteresis		20	

(2) Specified by design. Not production tested.

DEVICE INFORMATION FUNCTIONAL BLOCK DIAGRAM

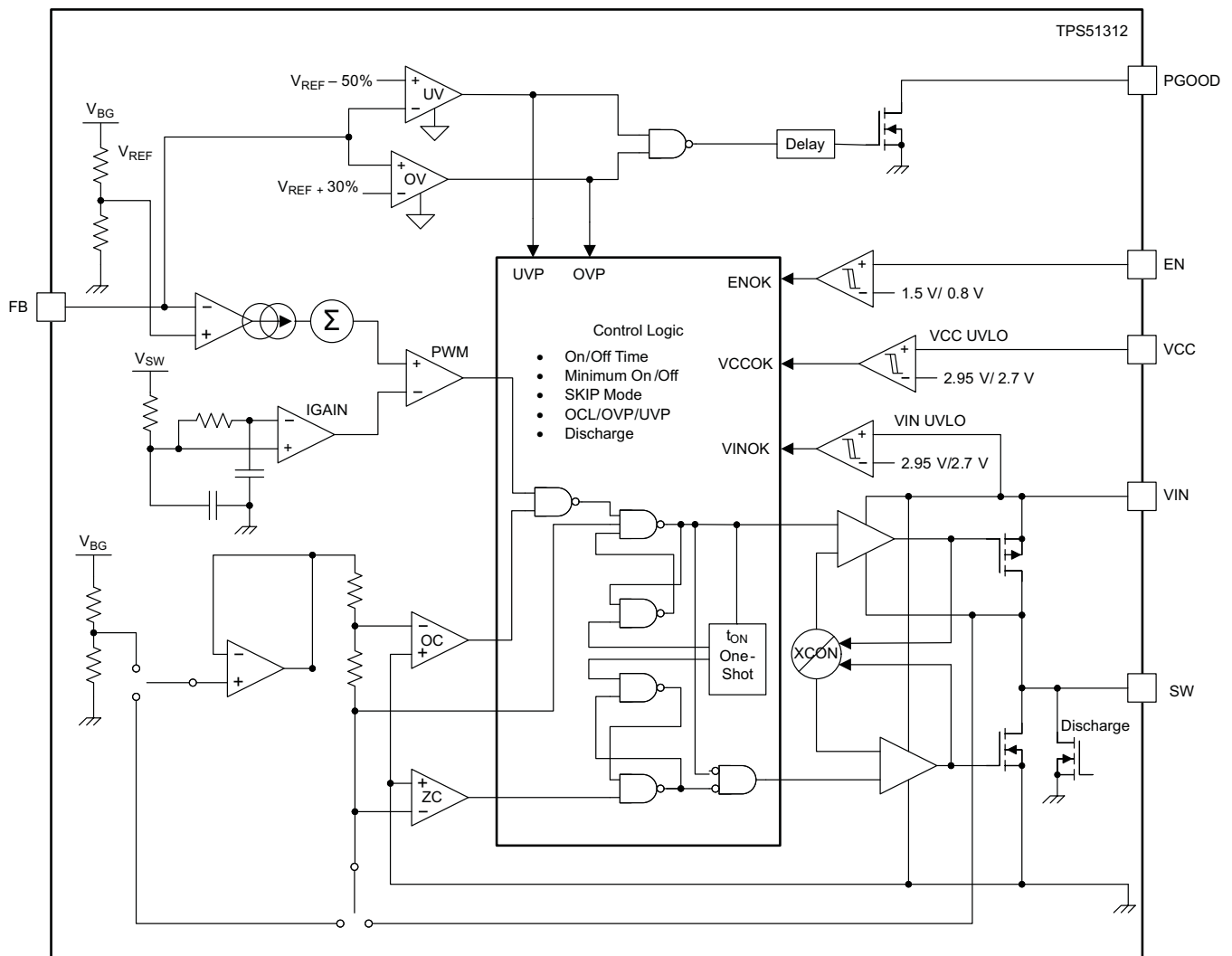

UDG-12124

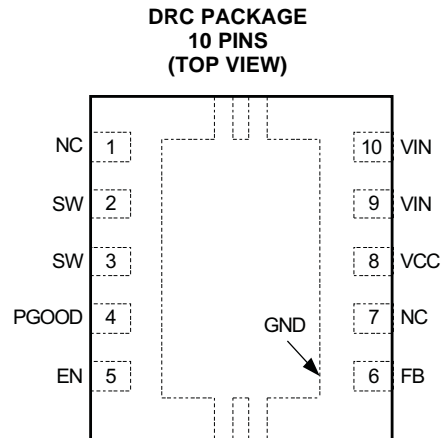

PIN FUNCTIONS

PIN		I/O	DESCRIPTION
NAME	NO.		
EN	5	I	Enable function for the switched-mode power supply (SMPS) (3.3-V logic compatible)
FB	6	I	Voltage feedback. Also used for OVP, UVP and PGOOD determination.
NC	1 7	–	No connection. Make no external connection to this pin.
PGOOD	4	O	Power good indicator. Requires external pull-up resistor.
SW	2 3	I	Switching node output. Connect to external inductor. Also serve as current sensing negative input for over current protection purpose
VCC	8	I	Power supply for analog circuit.
VIN	9 10	I	Main power conversion input and gate-drive voltage supply for output FETs.
Thermal Pad		I	Ground terminal.

TYPICAL CHARACTERISTICS

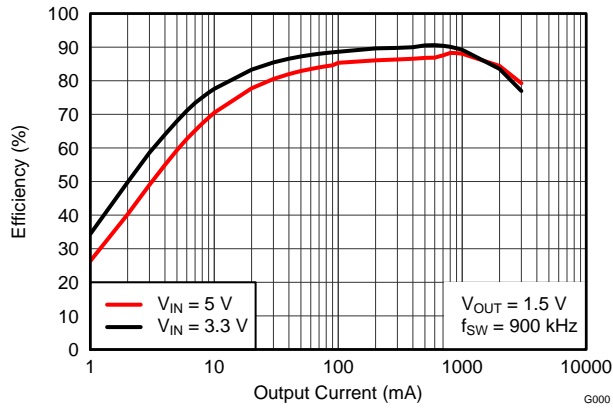

Figure 1. Efficiency vs. Output Current

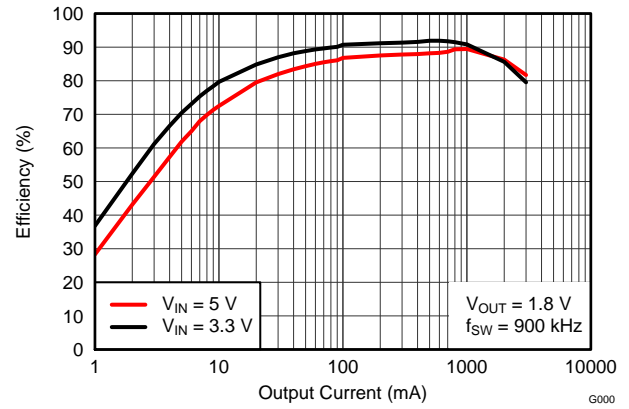

Figure 2. Efficiency vs. Output Current

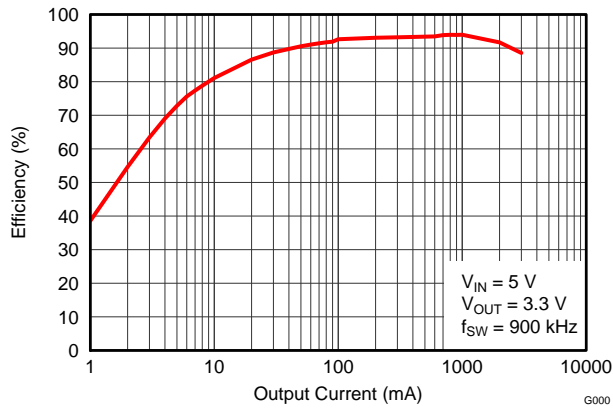

Figure 3. Efficiency vs. Output Current

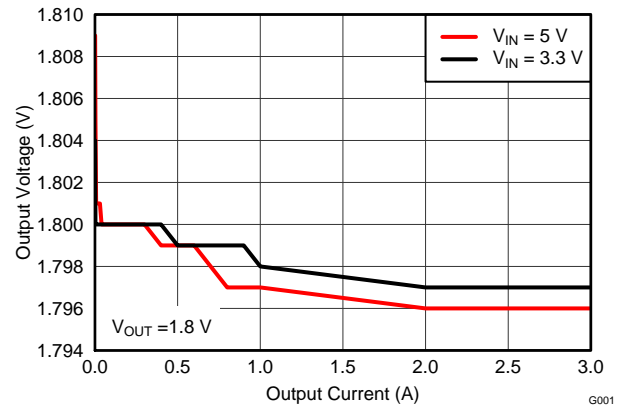

Figure 4. DC Load Regulation

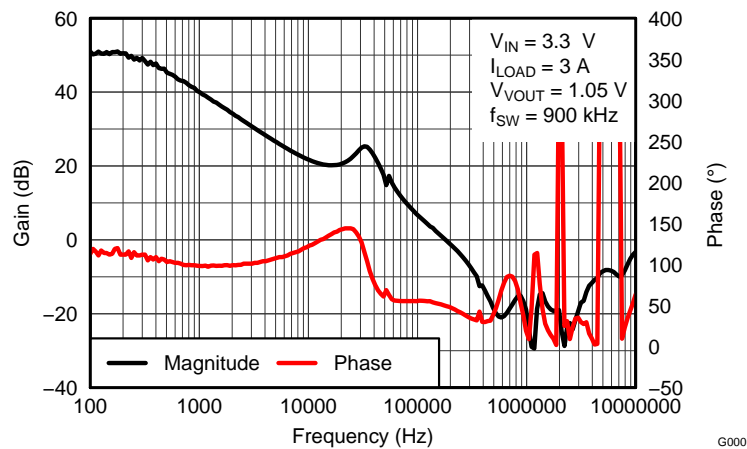

Figure 5. Bode Plot

TYPICAL CHARACTERISTICS (continued)

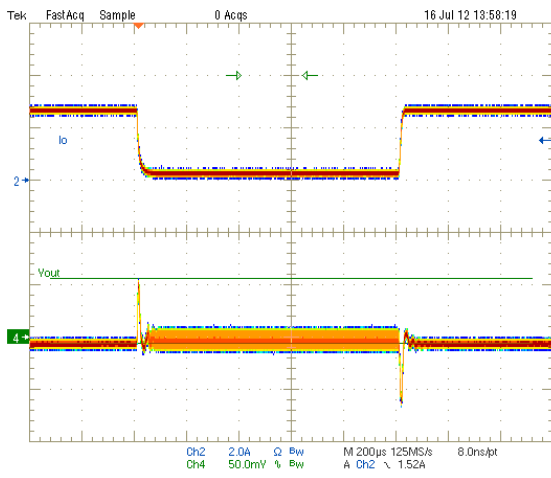

Figure 6. 3.3-V Input, 1.8-V Output from 0 A to 3 A

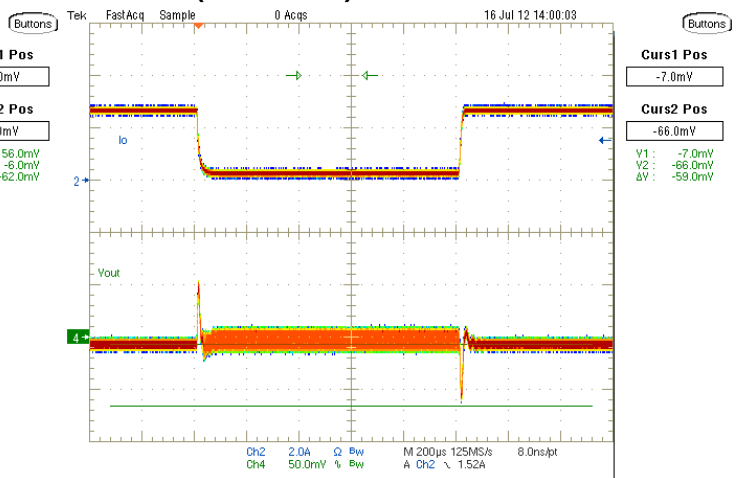

Figure 7. 5-V Input, 1.8-V Output from 0 A to 3 A

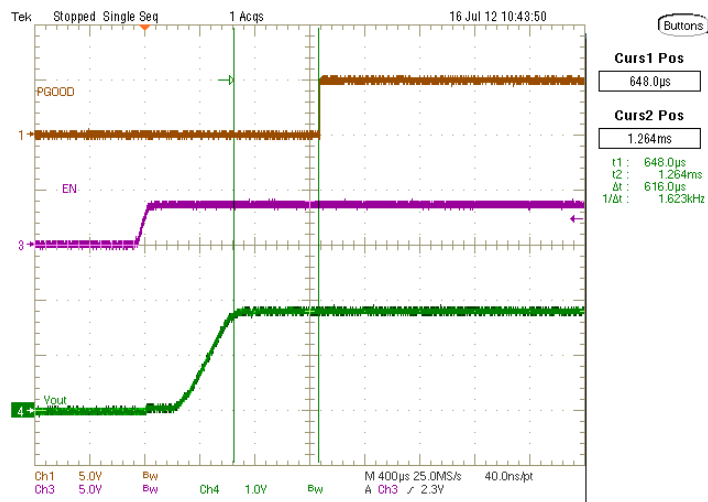

Figure 8. 5-V Input, 1.8-V Output Start-Up

APPLICATION INFORMATION

Functional Overview

TPS51312 is a D-CAP2 mode adaptive on time converter with internal integrator. Monolithically integrate high side and low side FET supports output current to a maximum of 3-ADC. The converter automatically runs in discontinuous conduction mode to optimize light load efficiency. A switching frequency of 900 kHz enables optimization of the power train for the cost, size and efficiency performance of the design.

PWM Operation

The PWM operation is comprised of three separate loops, A, B and C as shown in Figure 9.

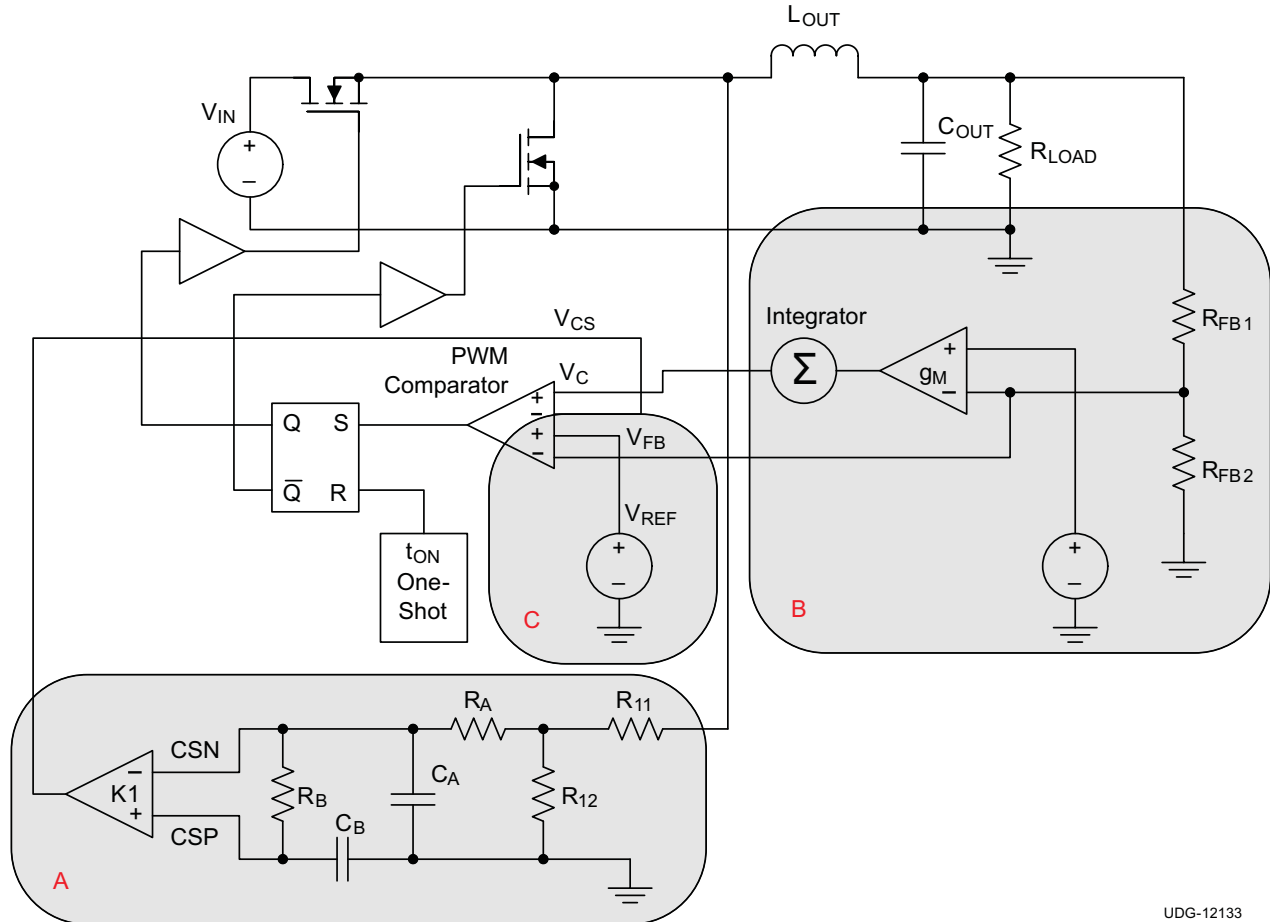

UDG-12133

Figure 9. ³/₄PWM Operation

Internal Current Loop (A)

Loop A is the internal current loop. The current information is sampled, divided and averaged at the SW node. The RC time constant and the gain of the current sense amplifier is chosen to cover the wide range of power stage design intended for this application.

Internal Voltage Loop (B)

Loop B is the internal voltage loop. The feedback voltage information is compared to the voltage reference at the input of the gm amplifier, the internal integrator is designed to provide a zero at the double pole location to boost phase margin at the desired crossover frequency.

Fast Feedforward Loop (C)

Loop C is the additional loop that acts a direct fast feedforward loop to enhance the transient response.

In steady state operation as shown in Figure 10, the on time is initiated by the interaction of the three loops mentioned above. When the $(V_C - V_{CS})$ is rising above threshold defined by $(V_{FB} - V_{REF})$, the PWM comparator issues the on time pulse after the propagation delay. The demand of on time occurs when the artificial current has reached the valley point. The load regulation is maintained by the integrator provided by the g_M amplifier and integrator.

In transient operation as shown in Figure 11, the benefit of this topology is becoming evident. In an all MLCC output configuration, especially when the output capacitance is low, when the load step is applied, the output voltage is immediately discharged to try to keep the load demand. The immediate reflection of the load demand is instantly reflected in the FB voltage. The $(V_{FB} - V_{REF})$ is thus served as a termination voltage level for the $(V_C - V_{CS})$, thus modulating the initiation of the on time. The transient response can be improved further by amplifying the difference between V_{FB} and the V_{REF} reference.

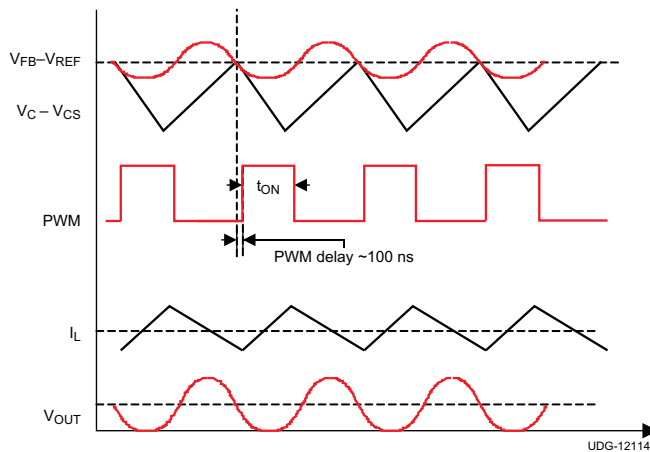

Figure 10. Steady-State Operation

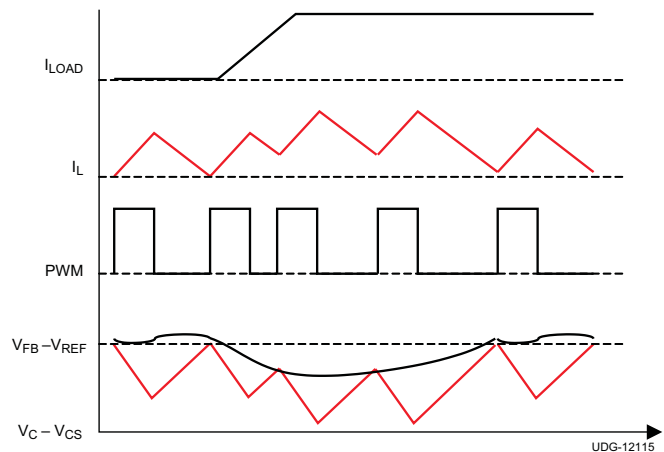

Figure 11. Transient Operation

PWM Frequency

The TPS51312 operates at a switching frequency of 900 kHz.

Light Load Power Saving Features

The TPS51312 offers an automatic pulse-skipping feature to provide excellent efficiency over the entire load range. The converter senses the current during low side FET on and prevents negative current flow by turning off the low side FET. This saves power by eliminating re-circulation of the inductor current. When the bottom FET is turned off, the converter enters discontinuous mode, and the switching frequency decreases, reducing switching loss.

Power Sequences

TPS51312 initiates the soft-start process when the EN, VIN and VCC pins are ready. The soft-start time 300 μ s when the reference voltage is between 0 V and 0.6 V (V_{REF}). The actual voltage ramp up time is the same as that of the V_{REF} start-up time, which is 300 μ s.

Power Good Signal

The TPS51312 has one open-drain power good (PGOOD) pin. During initial startup, there is a 1.3-ms power good high propagation delay after EN goes high. The PGOOD de-asserts when the EN is pulled low or an undervoltage condition on VCC or VIN or any other faults (such as V_{OUT} , UVP, OCP, OVP) that require latch off action is detected.

Protection Features

The TPS51312 offers many features to protect the converter power chain as well as the system electronics.

Input Undervoltage Protection on V_{CC} and V_{IN} (UVLO)

The TPS51312 continuously monitor the voltage on the V_{CC} and V_{IN} to ensure the voltage level is high enough to bias the converter properly and to provide sufficient gate drive potential to maintain high efficiency for the converter. The converter starts with V_{CC} and V_{IN} approximately 2.95 V and has a nominal of 250 mV of hysteresis, assuming EN is above the logic threshold level. If the UVLO level is reached for either V_{CC} or V_{IN} , the converter transitions the SW node into a tri-state and remains off until the device is reset by both V_{CC} and V_{IN} reaches 2.95 V (nominal). The PGOOD is deasserted when UVLO is detected and remains low until the device is reset.

Output Overvoltage Protection (OVP)

The TPS51312 has OVP protection circuit. An OVP event is detected when the FB voltage is approximately $130\% \times 0.6V_{REF}$. In this case, the converter de-asserts the PGOOD signal and performs the overvoltage protection function. The converter latches off both high-side and low-side FET and remains in this state after a delay of 1.9 μ s (typ) until the device is reset by EN, or V_{CC} or V_{IN} .

Output Undervoltage Protection (UVP)

Output undervoltage protection works in conjunction with the current protection described in the [Overcurrent and Current Limit Protection](#) section. If the FB voltage drops below $50\% \times 0.6 V_{REF}$, after a delay of 2.4 μ s (typ), the converter latches off. Undervoltage protection can be reset by EN, V_{CC} or V_{IN} .

Overcurrent and Current Limit Protection

The TPS51312 provides an overcurrent protection function. The nominal OCP is 4.8-A DC. When the current limit is exceeded for consecutive 9 cycles, the converter latches off and remains latched off until it is reset by EN, V_{CC} or V_{IN} .

The TPS51312 also provides current limit protection function. If the sense current is above the OCL setting, the converter delays the next on pulse until the current level drops below the OCL limit. Current limiting occurs on a pulse-by-pulse basis. During a fast or very fast overcurrent event, the output voltage tends to droop until the UVP limit is reached. Then the converter de-asserts the PGOOD signal, and latches off after a typical delay time of 2.4 μ s. The converter remains in this state until the device is reset by EN, V_{CC} or V_{IN} .

Thermal Protection

The TPS51312 has an internal temperature sensor. When the die temperature reaches a nominal of 145°C, the device shuts down until the temperature cools by approximately 20°C. Then the converter restarts. The thermal shutdown is a non-latched behavior.

REFERENCE DESIGN

Application Schematic

Figure 12 shows the application schematic..

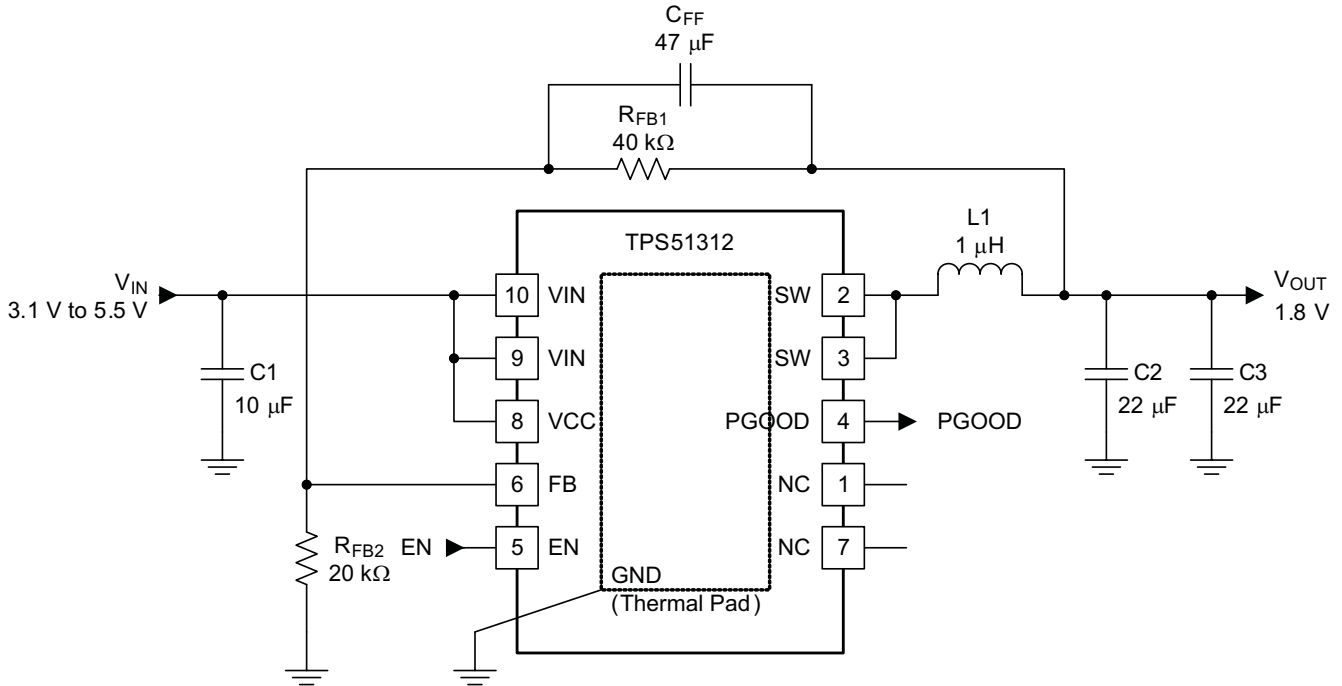

UDG-12145

Figure 12. Reference Design Schematic

Table 1. Reference Design List of Materials

FUNCTION	MANUFACTURER	PART NUMBER
Output Inductor	Vishay	IHLP-2020BZ-01
Ceramic Output Capacitors	Panasonic	ECJ2FB0J226M
	Murata	GRM21BR60J226ME39L

Design Procedure

Step One. Determine the specifications.

- $V_{OUT} = 1.8\text{ V}$
- $I_{CC(max)} = 3\text{ A}$
- $di/dt = 2.5\text{ A}/\mu\text{s}$

Step Two. Determine the system parameters.

The input voltage range and operating frequency are of primary interest. For example,

- $V_{IN} = V_{CC} = 5\text{ V}$
- $f_{SW} = 900\text{ kHz}$.

Step Three. Set the output voltage.

 Use [Equation 1](#) to determine the output voltage.

$$V_{OUT} = V_{REF} \times \left(\frac{R_{FB1} + R_{FB2}}{R_{FB2}} \right) \quad (1)$$

The output voltage is determined by VREF (0.6 V) and the resistor dividers (R_{FB1} and R_{FB2}). The output voltage is regulated to the FB pin. For the current reference design of 1.8 V, select 40 kΩ as the value for R_{FB1} and 20 kΩ as the value of R_{FB2} (see [Figure 12](#)). As a recommendation, choose a value of less 50 kΩ both resistors. Place a 47-pF, feedforward capacitor in parallel with R_{FB1} to help reduce the output voltage ripple during the transition from DCM to CCM.

Step Four. Determine inductor value and choose inductor.

Smaller inductance yields better transient performance but the consequence is higher ripple and lower efficiency. Higher values have the opposite characteristics. It is common practice to limit the ripple current to 25% to 50% of the maximum current. In this case, use 40%:

$$I_{P-P} = 3A \times 0.4 = 1.2A$$

where

- f_{SW} = 900 kHz
 - V_{IN} = 5 V
 - V_{OUT} = 1.8 V
- (2)

$$L = \frac{V \times dT}{I_{P-P}} = \left(\frac{V_{IN} - V_{OUT}}{I_{P-P}} \right) \times \left(\frac{V_{OUT}}{f_{SW} \times V_{IN}} \right) = 1\mu H \quad (3)$$

For this application, choose a 1-μH, 18.9-mΩ inductor from Vishay part number IHLP-2020BZ-01.

Step Five. Determine the output capacitance.

To determine C_{OUT} based on transient and stability requirement, first calculate the minimum output capacitance for a given transient.

[Equation 4](#) and [Equation 5](#) calculate the minimum output capacitance for meeting the transient requirement.

$$C_{OUT(min_under)} = \frac{L \times \Delta I_{LOAD(max)}^2 \times \left(\frac{V_{VOUT} \times t_{SW}}{V_{IN(min)}} + t_{MIN(off)} \right)}{2 \times \Delta V_{LOAD(insert)} \times \left(\left(\frac{V_{IN(min)} - V_{VOUT}}{V_{IN(min)}} \right) \times t_{SW} - t_{MIN(off)} \right) \times V_{VOUT}} \quad (4)$$

$$C_{OUT(min_over)} = \frac{L_{OUT} \times (\Delta I_{LOAD(max)})^2}{2 \times \Delta V_{LOAD(release)} \times V_{VOUT}} \quad (5)$$

Table 2. Choosing Output Inductors and Output Capacitors

TEMPERATURE	OUTPUT VOLTAGE V _{OUT} (V)	INDUCTANCE L _{OUT} (μH)	OUTPUT CAPACITORS		FAST FEEDFORWARD CAPACITOR C _{FF} (pF)
			NUMBER	VALUE (μF)	
-10°C ≤ T _A ≤ 85°C	1.5	1	1	22	47
	1.8	1	1		
	3.3	2.2	2		
-40°C ≤ T _A ≤ 85°C	1.5	1	2		
	1.8	1	2		
	3.3	2.2	3		

Step Six. Establishing the internal compensation loop.

The TPS51312 is designed with an internal compensation loop. The internal integrator zero location is approximately 60 kHz. During the time that the power stage double pole frequency contributed by the L_{OUT} and C_{OUT} is less than or equal to that of the zero location, the converter is stable with sufficient margin.

Step Seven. Select decoupling and peripheral components.

For TPS51312 peripheral capacitors use the following minimum value of ceramic capacitance, X5R or better temperature coefficient is recommended. Tighter tolerances and higher voltage ratings are always appropriate.

V_{CC} and V_{IN} decoupling $\geq 2 \times 10 \mu\text{F}$, 6.3 V

Pull up resistor on PGOOD = 100 k Ω

Layout Considerations

Good layout is essential for stable power supply operation. Follow these guidelines for an efficient PCB layout.

- Place V_{IN} , V_{CC} decoupling capacitors as close to the device as possible.
- Use wide traces for the VIN, SW and GND pins. These nodes carry high current and also serve as heat sinks.
- Place FB and voltage setting dividers as close to the device as possible.
- Place an R-C network from SW to GND to help to reduce the voltage spikes on the SW pin.

PACKAGING INFORMATION

Orderable Device	Status (1)	Package Type	Package Drawing	Pins	Package Qty	Eco Plan (2)	Lead/Ball Finish (6)	MSL Peak Temp (3)	Op Temp (°C)	Device Marking (4/5)	Samples
FX012	ACTIVE	VSON	DRC	10	3000	Green (RoHS & no Sb/Br)	CU NIPDAU	Level-2-260C-1 YEAR	-40 to 85	S51312	Samples
TPS51312DRCR	ACTIVE	VSON	DRC	10	3000	Green (RoHS & no Sb/Br)	CU NIPDAU	Level-2-260C-1 YEAR	-40 to 85	S51312	Samples
TPS51312DRCT	ACTIVE	VSON	DRC	10	250	Green (RoHS & no Sb/Br)	CU NIPDAU	Level-2-260C-1 YEAR	-40 to 85	S51312	Samples

(1) The marketing status values are defined as follows:

ACTIVE: Product device recommended for new designs.

LIFEBUY: TI has announced that the device will be discontinued, and a lifetime-buy period is in effect.

NRND: Not recommended for new designs. Device is in production to support existing customers, but TI does not recommend using this part in a new design.

PREVIEW: Device has been announced but is not in production. Samples may or may not be available.

OBSOLETE: TI has discontinued the production of the device.

(2) Eco Plan - The planned eco-friendly classification: Pb-Free (RoHS), Pb-Free (RoHS Exempt), or Green (RoHS & no Sb/Br) - please check <http://www.ti.com/productcontent> for the latest availability information and additional product content details.

TBD: The Pb-Free/Green conversion plan has not been defined.

Pb-Free (RoHS): TI's terms "Lead-Free" or "Pb-Free" mean semiconductor products that are compatible with the current RoHS requirements for all 6 substances, including the requirement that lead not exceed 0.1% by weight in homogeneous materials. Where designed to be soldered at high temperatures, TI Pb-Free products are suitable for use in specified lead-free processes.

Pb-Free (RoHS Exempt): This component has a RoHS exemption for either 1) lead-based flip-chip solder bumps used between the die and package, or 2) lead-based die adhesive used between the die and leadframe. The component is otherwise considered Pb-Free (RoHS compatible) as defined above.

Green (RoHS & no Sb/Br): TI defines "Green" to mean Pb-Free (RoHS compatible), and free of Bromine (Br) and Antimony (Sb) based flame retardants (Br or Sb do not exceed 0.1% by weight in homogeneous material)

(3) MSL, Peak Temp. - The Moisture Sensitivity Level rating according to the JEDEC industry standard classifications, and peak solder temperature.

(4) There may be additional marking, which relates to the logo, the lot trace code information, or the environmental category on the device.

(5) Multiple Device Markings will be inside parentheses. Only one Device Marking contained in parentheses and separated by a "~" will appear on a device. If a line is indented then it is a continuation of the previous line and the two combined represent the entire Device Marking for that device.

(6) Lead/Ball Finish - Orderable Devices may have multiple material finish options. Finish options are separated by a vertical ruled line. Lead/Ball Finish values may wrap to two lines if the finish value exceeds the maximum column width.

Important Information and Disclaimer: The information provided on this page represents TI's knowledge and belief as of the date that it is provided. TI bases its knowledge and belief on information provided by third parties, and makes no representation or warranty as to the accuracy of such information. Efforts are underway to better integrate information from third parties. TI has taken and

continues to take reasonable steps to provide representative and accurate information but may not have conducted destructive testing or chemical analysis on incoming materials and chemicals. TI and TI suppliers consider certain information to be proprietary, and thus CAS numbers and other limited information may not be available for release.

In no event shall TI's liability arising out of such information exceed the total purchase price of the TI part(s) at issue in this document sold by TI to Customer on an annual basis.

TAPE AND REEL INFORMATION

QUADRANT ASSIGNMENTS FOR PIN 1 ORIENTATION IN TAPE

*All dimensions are nominal

Device	Package Type	Package Drawing	Pins	SPQ	Reel Diameter (mm)	Reel Width W1 (mm)	A0 (mm)	B0 (mm)	K0 (mm)	P1 (mm)	W (mm)	Pin1 Quadrant
TPS51312DRCR	VSON	DRC	10	3000	330.0	12.4	3.3	3.3	1.1	8.0	12.0	Q2
TPS51312DRCT	VSON	DRC	10	250	180.0	12.4	3.3	3.3	1.1	8.0	12.0	Q2

TAPE AND REEL BOX DIMENSIONS

*All dimensions are nominal

Device	Package Type	Package Drawing	Pins	SPQ	Length (mm)	Width (mm)	Height (mm)
TPS51312DRCR	VSON	DRC	10	3000	367.0	367.0	35.0
TPS51312DRCT	VSON	DRC	10	250	210.0	185.0	35.0

DRC (S-PVSON-N10)

PLASTIC SMALL OUTLINE NO-LEAD

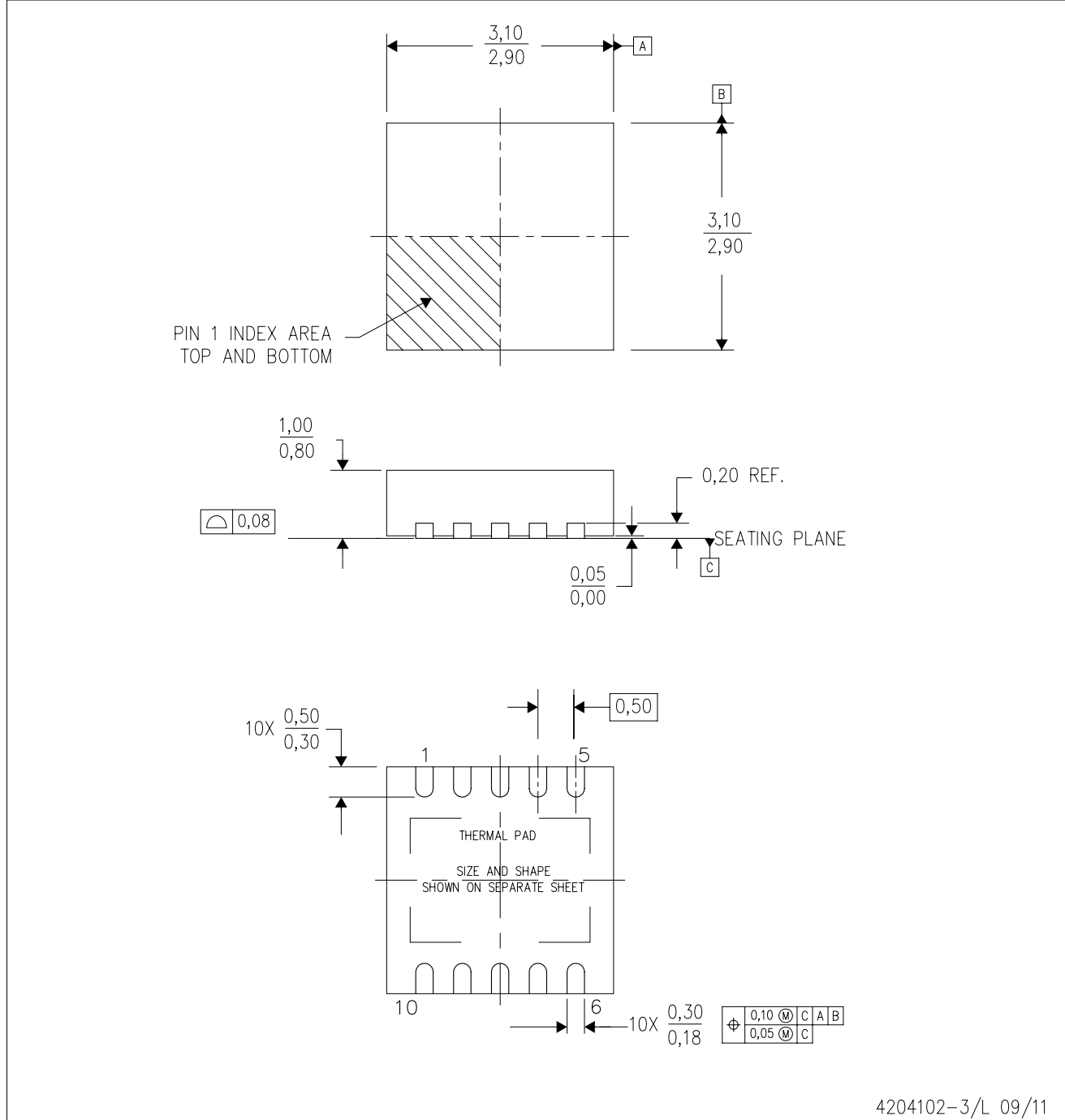

- NOTES:
- All linear dimensions are in millimeters. Dimensioning and tolerancing per ASME Y14.5M-1994.
 - This drawing is subject to change without notice.
 - Small Outline No-Lead (SON) package configuration.
 - The package thermal pad must be soldered to the board for thermal and mechanical performance, if present.
 - See the additional figure in the Product Data Sheet for details regarding the exposed thermal pad features and dimensions, if present

THERMAL PAD MECHANICAL DATA

DRC (S-PVSON-N10)

PLASTIC SMALL OUTLINE NO-LEAD

THERMAL INFORMATION

This package incorporates an exposed thermal pad that is designed to be attached directly to an external heatsink. The thermal pad must be soldered directly to the printed circuit board (PCB). After soldering, the PCB can be used as a heatsink. In addition, through the use of thermal vias, the thermal pad can be attached directly to the appropriate copper plane shown in the electrical schematic for the device, or alternatively, can be attached to a special heatsink structure designed into the PCB. This design optimizes the heat transfer from the integrated circuit (IC).

For information on the Quad Flatpack No-Lead (QFN) package and its advantages, refer to Application Report, QFN/SON PCB Attachment, Texas Instruments Literature No. SLUA271. This document is available at www.ti.com.

The exposed thermal pad dimensions for this package are shown in the following illustration.

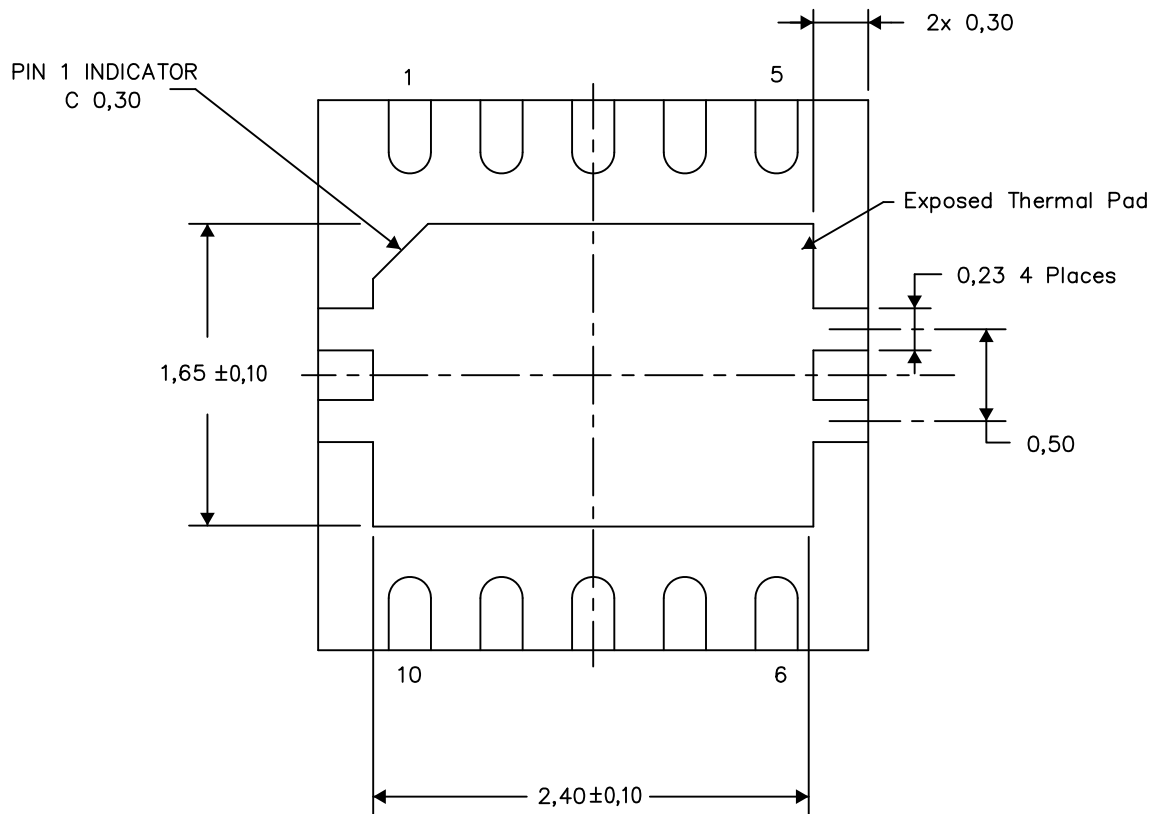

Bottom View

Exposed Thermal Pad Dimensions

4206565-3/Y 08/15

NOTE: A. All linear dimensions are in millimeters

IMPORTANT NOTICE

Texas Instruments Incorporated (TI) reserves the right to make corrections, enhancements, improvements and other changes to its semiconductor products and services per JESD46, latest issue, and to discontinue any product or service per JESD48, latest issue. Buyers should obtain the latest relevant information before placing orders and should verify that such information is current and complete.

TI's published terms of sale for semiconductor products (<http://www.ti.com/sc/docs/stdterms.htm>) apply to the sale of packaged integrated circuit products that TI has qualified and released to market. Additional terms may apply to the use or sale of other types of TI products and services.

Reproduction of significant portions of TI information in TI data sheets is permissible only if reproduction is without alteration and is accompanied by all associated warranties, conditions, limitations, and notices. TI is not responsible or liable for such reproduced documentation. Information of third parties may be subject to additional restrictions. Resale of TI products or services with statements different from or beyond the parameters stated by TI for that product or service voids all express and any implied warranties for the associated TI product or service and is an unfair and deceptive business practice. TI is not responsible or liable for any such statements.

Buyers and others who are developing systems that incorporate TI products (collectively, "Designers") understand and agree that Designers remain responsible for using their independent analysis, evaluation and judgment in designing their applications and that Designers have full and exclusive responsibility to assure the safety of Designers' applications and compliance of their applications (and of all TI products used in or for Designers' applications) with all applicable regulations, laws and other applicable requirements. Designer represents that, with respect to their applications, Designer has all the necessary expertise to create and implement safeguards that (1) anticipate dangerous consequences of failures, (2) monitor failures and their consequences, and (3) lessen the likelihood of failures that might cause harm and take appropriate actions. Designer agrees that prior to using or distributing any applications that include TI products, Designer will thoroughly test such applications and the functionality of such TI products as used in such applications.

TI's provision of technical, application or other design advice, quality characterization, reliability data or other services or information, including, but not limited to, reference designs and materials relating to evaluation modules, (collectively, "TI Resources") are intended to assist designers who are developing applications that incorporate TI products; by downloading, accessing or using TI Resources in any way, Designer (individually or, if Designer is acting on behalf of a company, Designer's company) agrees to use any particular TI Resource solely for this purpose and subject to the terms of this Notice.

TI's provision of TI Resources does not expand or otherwise alter TI's applicable published warranties or warranty disclaimers for TI products, and no additional obligations or liabilities arise from TI providing such TI Resources. TI reserves the right to make corrections, enhancements, improvements and other changes to its TI Resources. TI has not conducted any testing other than that specifically described in the published documentation for a particular TI Resource.

Designer is authorized to use, copy and modify any individual TI Resource only in connection with the development of applications that include the TI product(s) identified in such TI Resource. NO OTHER LICENSE, EXPRESS OR IMPLIED, BY ESTOPPEL OR OTHERWISE TO ANY OTHER TI INTELLECTUAL PROPERTY RIGHT, AND NO LICENSE TO ANY TECHNOLOGY OR INTELLECTUAL PROPERTY RIGHT OF TI OR ANY THIRD PARTY IS GRANTED HEREIN, including but not limited to any patent right, copyright, mask work right, or other intellectual property right relating to any combination, machine, or process in which TI products or services are used. Information regarding or referencing third-party products or services does not constitute a license to use such products or services, or a warranty or endorsement thereof. Use of TI Resources may require a license from a third party under the patents or other intellectual property of the third party, or a license from TI under the patents or other intellectual property of TI.

TI RESOURCES ARE PROVIDED "AS IS" AND WITH ALL FAULTS. TI DISCLAIMS ALL OTHER WARRANTIES OR REPRESENTATIONS, EXPRESS OR IMPLIED, REGARDING RESOURCES OR USE THEREOF, INCLUDING BUT NOT LIMITED TO ACCURACY OR COMPLETENESS, TITLE, ANY EPIDEMIC FAILURE WARRANTY AND ANY IMPLIED WARRANTIES OF MERCHANTABILITY, FITNESS FOR A PARTICULAR PURPOSE, AND NON-INFRINGEMENT OF ANY THIRD PARTY INTELLECTUAL PROPERTY RIGHTS. TI SHALL NOT BE LIABLE FOR AND SHALL NOT DEFEND OR INDEMNIFY DESIGNER AGAINST ANY CLAIM, INCLUDING BUT NOT LIMITED TO ANY INFRINGEMENT CLAIM THAT RELATES TO OR IS BASED ON ANY COMBINATION OF PRODUCTS EVEN IF DESCRIBED IN TI RESOURCES OR OTHERWISE. IN NO EVENT SHALL TI BE LIABLE FOR ANY ACTUAL, DIRECT, SPECIAL, COLLATERAL, INDIRECT, PUNITIVE, INCIDENTAL, CONSEQUENTIAL OR EXEMPLARY DAMAGES IN CONNECTION WITH OR ARISING OUT OF TI RESOURCES OR USE THEREOF, AND REGARDLESS OF WHETHER TI HAS BEEN ADVISED OF THE POSSIBILITY OF SUCH DAMAGES.

Unless TI has explicitly designated an individual product as meeting the requirements of a particular industry standard (e.g., ISO/TS 16949 and ISO 26262), TI is not responsible for any failure to meet such industry standard requirements.

Where TI specifically promotes products as facilitating functional safety or as compliant with industry functional safety standards, such products are intended to help enable customers to design and create their own applications that meet applicable functional safety standards and requirements. Using products in an application does not by itself establish any safety features in the application. Designers must ensure compliance with safety-related requirements and standards applicable to their applications. Designer may not use any TI products in life-critical medical equipment unless authorized officers of the parties have executed a special contract specifically governing such use. Life-critical medical equipment is medical equipment where failure of such equipment would cause serious bodily injury or death (e.g., life support, pacemakers, defibrillators, heart pumps, neurostimulators, and implantables). Such equipment includes, without limitation, all medical devices identified by the U.S. Food and Drug Administration as Class III devices and equivalent classifications outside the U.S.

TI may expressly designate certain products as completing a particular qualification (e.g., Q100, Military Grade, or Enhanced Product). Designers agree that it has the necessary expertise to select the product with the appropriate qualification designation for their applications and that proper product selection is at Designers' own risk. Designers are solely responsible for compliance with all legal and regulatory requirements in connection with such selection.

Designer will fully indemnify TI and its representatives against any damages, costs, losses, and/or liabilities arising out of Designer's non-compliance with the terms and provisions of this Notice.