

POWER MANAGEMENT IC FOR DIGITAL SET TOP BOXES

FEATURES

- **Wide Input Supply Voltage Range (10.8 V - 22 V)**
- **One Adjustable PWM Buck Controller**
 - 10.8-V - 22-V Input Voltage Range
 - 3.3-V - 6.1-V Output Voltage Range
 - 500kHz switching frequency
 - Type III Compensation
 - Programmable Current Limit
- **Two Adjustable Step-Down Converter with Integrated Switching FETs:**
 - 4.75-V - 5.5-V Input
 - 0.9-V-3.3-V Output Voltage Range
 - 3-A Output Current
 - 1-MHz Switching Frequency
 - Voltage Scaling Option
 - Type III Compensation
- **Two 100-mΩ, 0.5-A (TPS65230) 1-A (TPS65231) USB Switches with Over Current Protection and Open-Drain Fault Pin**
- **Early Supply Failure Flag (Open Drain Output) is Set when Input Voltage Drops Below 9.3 V**
- **Early Temperature Warning Flag (Open Drain Output) is Set if Temperature Approaches Shut-Down Threshold**

- **Supply Voltage Supervisor Circuit with Two Monitor Inputs and Open Drain Output**
- **Parallel I/O or I²C Control with User Selectable Address**
- **Advanced Fault Detection and Output Voltage Adjustment Options in I²C Mode**
- **Pull-Up Current Sources on Buck Enable Pins for Accurate Start-Up Timing Control with Preset Default**
- **Over Current Protection on All Rails**
- **Thermal Shutdown to Protect Device During Excessive Power Dissipation**
- **Thermally Enhanced Package for Efficient Heat Management (48-pin HTSSOP)**

APPLICATIONS

- **Digital Set Top Boxes**
- **xDSL & Cable Modems**
- **DVD Players**
- **Home Gateway and Access Point Networks**
- **Wireless Routers**

DESCRIPTION/ORDERING INFORMATION

The TPS652x provides one PWM buck controller, two adjustable, synchronous buck regulators, two independent USB power switches and a supply voltage supervisor (SVS) to provide main power functions for satellite set top boxes, xDSL and cable modem applications operating off a single 12- to 22-V supply.

The SMPS have integrated switching FETs for optimized power efficiency and reduced external component count. Each USB switch provides up to 0.5-A (TPS65230) or 1-A (TPS65231) of current as required by downstream USB devices. All power blocks have thermal and over current/short circuit protection.

The SVS provides two inputs for monitoring positive supply rails. The active-low open-drain output remains low for at least 180 ms after all supply rails rise above their rising edge threshold. Threshold value for VMON1 input is set for monitoring a 3.3-V rail without the need for additional external components. Threshold for VMON2 input is set to 0.8 V and requires resistor dividers on the input to monitor any positive voltage in the system. The nBOR/nHOT open-drain output is pulled low if the input supply drops below 9.3 V or the chip temperature approaches the thermal shutdown limit. This allows the system processor to save critical data and shut down gracefully before the supply fails.



Please be aware that an important notice concerning availability, standard warranty, and use in critical applications of Texas Instruments semiconductor products and disclaimers thereto appears at the end of this data sheet.

The TPS65230 and TPS65231 can be controlled either through parallel I/Os or through I²C interface. When the pull-up resistor on the USBFLAG2/nINT pin is connected to a 3.3-V or lower supply the I²C interface is disabled and the device is controlled through parallel I/O pins only. With the pull-up resistor connected to 6 V the I²C interface is enabled and the device is controlled by writing to the control registers. Any fault or abnormal operating condition is flagged by the interrupt pin. The interrupt is cleared by reading the status register via the I²C interface.

FUNCTIONAL BLOCK DIAGRAM

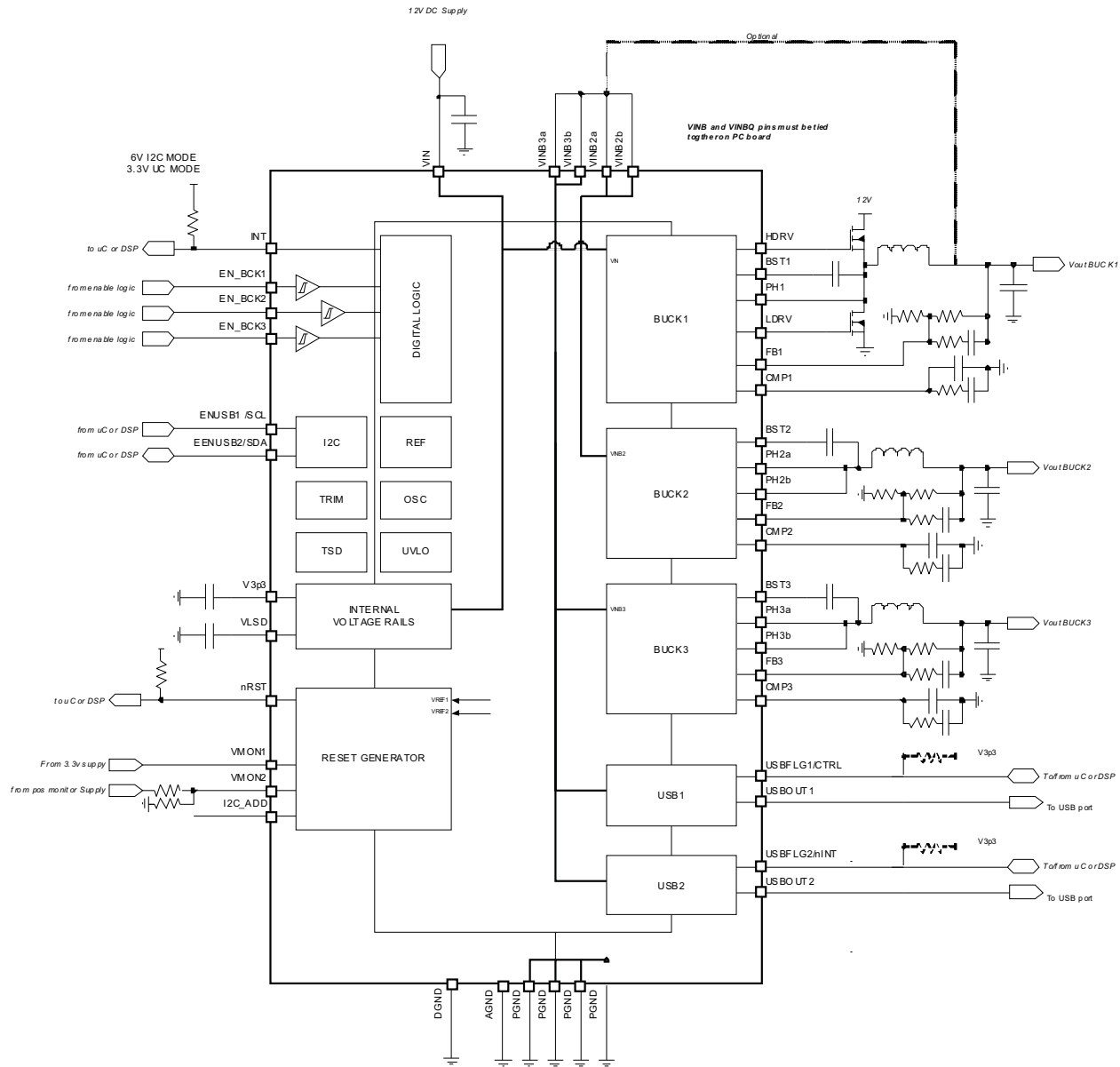

ORDERING INFORMATION⁽¹⁾

| T _A | PACKAGE ⁽²⁾ | | ORDERABLE PART NUMBER | TOP-SIDE MARKING |
|----------------|------------------------|--------------|-----------------------|------------------|
| 0°C to 85°C | 48-pin (HTSSOP) - DCA | Reel of 2000 | TPS65230A2DCAR | TPS65230 |
| | | | TPS65231A2DCAR | TPS65231 |

- (1) For the most current package and ordering information, see the Package Option Addendum at the end of this document, or see the TI web site at www.ti.com.
- (2) Package drawings, thermal data, and symbolization are available at www.ti.com/packaging.

TERMINAL FUNCTIONS

| NAME | NO. | I/O | DESCRIPTION |
|---------------|--------|-----|--|
| BG | 1 | I | Reference filter pin |
| VINBQ | 2 | I | Reference supply for BUCK2 and BUCK3 |
| V6V | 3 | I | Filter pin for internal voltage regulator (6 V) |
| VIN | 4 | I | Input supply for BUCK1 and support circuitry |
| FB2 | 5 | I | Feedback pin (BUCK2) |
| CMP2 | 6 | I | Regulator compensation (BUCK2) |
| EN_BCK2 | 7 | I | Enable pin for BUCK2, active high |
| PGND2 | 8, 9 | | Power ground BUCK2 |
| PH2 | 10, 11 | O | Switching pin (BUCK2) |
| VINB2 | 12, 13 | | Input supply for BUCK2 (must be tied to VINB3, VINBQ) |
| BST2 | 14 | I | Bootstrap input (BUCK2) |
| DGND | 15 | | Digital ground. All grounds should be joined together. |
| LDRV | 16 | O | Low-side gate drive output (PWM controller) |
| HDRV | 17 | O | High-side gate drive output (PWM controller) |
| PH1 | 18 | O | Switching pin (BUCK1) |
| BST1 | 19 | I | Bootstrap input (BUCK1) |
| EN_BCK1 | 20 | I | Enable pin for BUCK1, active high |
| CMP1 | 21 | I | Regulator compensation (PWM controller) |
| FB1 | 22 | I | Feedback pin (PWM controller) |
| SS | 23 | I | External capacitor for soft start |
| TRIP | 24 | I | BUCK1 over current trip point set-up |
| V3P3 | 25 | I | Filter pin for internal voltage regulator (3.3 V) |
| AGND | 26 | | Analog ground |
| nRST | 27 | O | Reset output (open drain), active low |
| EN_USB1/SCL | 28 | I | Enable pin for USB switch 1, active high / Clock input (I ² C enabled). |
| EN_USB2/SDA | 29 | I | Enable pin for USB switch 2, active high / Data input (I ² C enabled) |
| USBFLAG2/nINT | 30 | I/O | USB2 fault flag / Interrupt pin |
| FB3 | 31 | I | Feedback pin (BUCK3) |
| CMP3 | 32 | I | Regulator compensation (BUCK3) |
| EN_BCK3 | 33 | I | Enable pin for BUCK3, active high |
| PGND3 | 34, 35 | | Power ground BUCK3 |
| PH3 | 36, 37 | O | Switching pin (BUCK3) |
| VINB3 | 38, 39 | I | Input supply for BUCK3 (must be tied to VINB2, VINBQ) |
| BST3 | 40 | I | Bootstrap input (BUCK3) |
| USBOUT1 | 41 | O | USB switch output (channel1) |
| VINU | 42 | I | Input supply for USB switches |
| USBOUT2 | 43 | O | USB switch output (channel2) |
| USBFLG1/VCTRL | 44 | I/O | USB1 fault flag, active low, open drain / Voltage control pin for BUCK2 (I ² C enabled) |
| nBOR/nHOT | 45 | I/O | Brownout and hot warning, active low, open drain |
| VMON1 | 46 | I | Voltage monitor input (3.3 V rail) |
| VMON2 | 47 | I | Voltage monitor input (positive reference) |
| I2C_ADD | 48 | I | If grounded, I ² C address is 48h. Tied to V3P3 I ² C address is 49. |

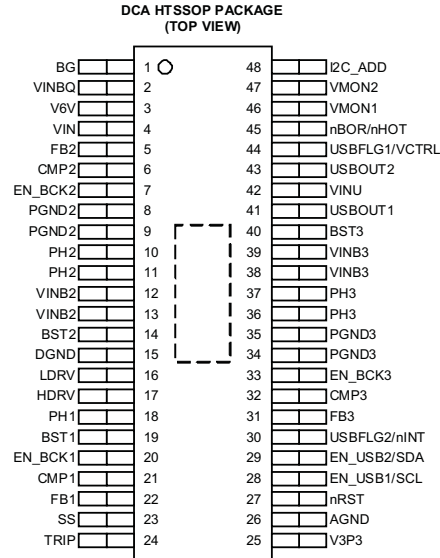

ABSOLUTE MAXIMUM RATINGS⁽¹⁾⁽²⁾

over operating free-air temperature range (unless otherwise noted)

| | | |
|--|---|---------------|
| Input voltage range at VIN | -0.3 to 25 | V |
| Input voltage range at VINB, VINBQ, VINU | -0.3 to 7.0 | V |
| Voltage range at INT | -0.3 to 7.0 | V |
| Voltage range at EN_BCK1, EN_BCK2, EN_BCK3, EN_USB1/SCL, EN_USB2/SDA, nRST, USBFLG1/VCTRL2, USBFLG2/VCTRL3 | -0.3 to 3.6 | V |
| Voltage on HDRV, BST1 | -0.3 to 31 | V |
| Voltage on PH1 | -0.3 to 24 | V |
| Voltage on FB1, CMP1, FB2, CMP2, FB3, CMP3 | -0.3 to 3.6 | V |
| Voltage on PH2, PH3, LDRV | -0.3 to 7.0 | V |
| Voltage on BST2, BST3 | -0.3 to 15V | V |
| Voltage on VMON1, VMON2, VMON3 | -0.3 to 3.6 | V |
| Output Current BUCK2, BUCK3 | 3.8 | A |
| Peak output current | Internally limited | |
| ESD rating | Human body model (HBM) | 2 k |
| | Charged device model (CDM) | 500 |
| θ_{JA} | Thermal Resistance – Junction to ambient ⁽³⁾ | 25 °C/W |
| | Continuous total power dissipation 55°C ⁽³⁾ no thermal warning | 2.6 W |
| T_J | Operating virtual junction temperature range | 0 to 150 °C |
| T_A | Operating ambient temperature range | 0 to 85 °C |
| T_{STG} | Storage temperature range | -65 to 150 °C |

- (1) Stresses beyond those listed under "absolute maximum ratings" may cause permanent damage to the device. These are stress ratings only, and functional operation of the device at these or any other conditions beyond those indicated under "recommended operating conditions" is not implied. Exposure to absolute-maximum-rated conditions for extended periods may affect device reliability.
- (2) All voltage values are with respect to network ground terminal.
- (3) Using JEDEC 51-5 (High K) board. This is based on standard 48DCA package, 4 layers, top/bottom layer: 2 oz Cu, inner layer: 1 oz Cu. Board size: 114.3 x 76.2 mm (4.5 x 3 inches), board thickness: 1.6 mm (0.0629 inch).

RECOMMENDED OPERATING CONDITIONS

over operating free-air temperature range (unless otherwise noted)

| | MIN | NOM | MAX | UNIT |
|---|------|-----|-----|------|
| Input voltage range at VIN | 10.8 | 12 | 22 | V |
| Input voltage range at VINU | 4.75 | | 5.5 | V |
| Input voltage range at VINB | 4.75 | | 6.1 | |
| Voltage range, EN_BCK1, EN_BCK2, EN_BCK3, EN_USB1/SCL, EN_USB2/SDA, nRST, USBFLG1/VCTRL2, USBFLG2/VCTRL3 pins | | | 3.3 | V |
| Input voltage, nRST pin | | | 3.3 | V |
| Voltage range, INT pin (I ² C disabled) | 5.4 | | 6.6 | V |
| Voltage range, INT pin (I ² C enabled) | | | 3.3 | V |
| T _A Ambient operating temperature | | | 50 | °C |

ELECTRICAL CHARACTERISTICS

 VIN = 12 V ±5%, VINB2, VINB3 = 5 V ±5%, VINU = 5 V ±5% T_J = 0°C to 150°C, unless otherwise noted.

| PARAMETER | TEST CONDITIONS | MIN | TYP | MAX | UNIT |
|---|--|--|------|------|------|
| INPUT VOLTAGE | | | | | |
| VIN | Input supply voltage | 10.8 | 12 | 22 | V |
| VBOR | Brown Out Reset threshold | VIN rising | | 10.8 | V |
| | | VIN falling | 9.3 | | |
| UVLO VIN | UVLO threshold – VIN (main supply) | VIN rising | | 10.8 | V |
| | | VIN falling | 4.7 | | |
| UVLO VINB | UVLO threshold – VINB (BUCK2/BUCK3 supply) | VINB rising | | 4.75 | V |
| | | VINB falling | 4.25 | | |
| UVLO VINU | UVLO threshold – VINU (USB supply) | VINU rising | | 4.4 | V |
| | | VINU falling | 3.8 | | |
| INPUT CURRENT | | | | | |
| I _{CCQ} | Input supply current | All regulators/USB switches disabled | | 4 | mA |
| LOGIC INPUT LEVEL (SCL, SDA, INT, VCTRL2, VCTRL3) | | | | | |
| V _{IH} | Input high level | 1.2 | | | V |
| V _{IL} | Input low level | | | 0.4 | V |
| V _{I2C_disable} | I ² C disable voltage (INT) | 4 | | | V |
| BUCK ENABLE INPUTS (EN_BCK1,2,3) | | | | | |
| VEN | Enable threshold | | 1.2 | | V |
| VEN _{HYS} | Enable voltage hysteresis | | 100 | | mV |
| I _{PULLUP} | Pull-up current | t _{EN} = 0.2 ms/nF | 6 | | µA |
| R _D | Discharge resistor | | | 1 | kΩ |
| t _D | Discharge time | Power-up | 5 | | ms |
| I²C ENABLE THRESHOLD (INT pin) | | | | | |
| VINT _{TH} | I ² C enable threshold | I ² C enabled if pull-up resistor is connected to a value above threshold | 4.8 | | V |
| LOGIC OUTPUT LEVEL(SDA, INT, nRST, USBFLG1, USBFLG2) | | | | | |
| OL | Output low level | I _{OUT} = 3 mA through pull-up | 0.3 | 0.4 | V |
| PWM CONTROLLER (BUCK1) | | | | | |
| V _{OUT} | Output voltage range ⁽¹⁾ | | 3.3 | 6.1 | V |
| PG | Power good threshold | V _{OUT} rising | | 95 | % |

(1) Output voltage range is limited by the minimum and maximum duty cycle. V_{OUT(min)} ~ d(min) x V_{INPUT} and V_{OUT(max)} ~ d(max) x V_{INPUT}.

ELECTRICAL CHARACTERISTICS (continued)VIN = 12 V ±5%, VINB2, VINB3 = 5 V ±5%, VINU = 5 V ±5% T_J = 0°C to 150°C, unless otherwise noted.

| PARAMETER | | TEST CONDITIONS | MIN | TYP | MAX | UNIT |
|----------------------|--|--|-------------------|-------|------|--------|
| UVD | Under voltage detect | V _{OUT} falling | | 75 | | % |
| V _{FB} | Feedback voltage | | -2% | 0.804 | 2% | V |
| LDRV HDRV | High and low side drive voltage | No load | | 6 | | V |
| R _{ONLDRV} | Low side ON resistance | | | 8 | | Ω |
| R _{OFFLDRV} | Low side OFF resistance | | | 1 | | Ω |
| R _{ONHDRV} | High side ON resistance | | | 20 | | Ω |
| R _{OFFHDRV} | High side OFF resistance | | | 1 | | Ω |
| d | Duty cycle ⁽²⁾ | | 20 | | 80 | % |
| A _{MOD} | Modulator gain | | | 12 | | |
| f _{SW} | Switching frequency | | | 500 | | kHz |
| I _{TRIP} | Current source for setting OCP trip point | T _A = 25°C | | 10 | | μA |
| TC _{TRIP} | Temperature coefficient of I _{TRIP} | | | 3700 | | ppm/°C |
| R _{TRIP} | Current-limit setting resistor | | 80 | | 250 | kΩ |
| C _{OUT} | Output capacitance | | 22 ⁽³⁾ | 47 | | μF |
| L | Nominal Inductance | Recommended | | 4.7 | | μH |
| BUCK2 | | | | | | |
| V _{OUT} | Output voltage range ⁽⁴⁾ | | 0.9 | | 3.3 | V |
| PG | Power good threshold | V _{OUT} rising | | 95 | | % |
| UVD | Under voltage detect | V _{OUT} falling | | 75 | | % |
| V _{FB} | Feedback voltage | | -2% | 0.804 | 2% | V |
| I _{OUT} | Output current | | | | 3000 | mA |
| η | Efficiency | I _O = 2 A, V _{OUT} = 3.3V | | 95 | | % |
| R _{DS(ON)} | Low-side MOSFET On resistance | VIN12V = 12 V | | 32 | | mΩ |
| | High-side MOSFET On resistance | | | 36 | | |
| I _{LIMIT} | Switch current limit | | | 5 | | A |
| | Current limit accuracy | | -30 | | 30 | % |
| V _{LINEREG} | Line regulation - DC ΔV _{OUT} /ΔV _{INB} | VINB = 4.75 V - 6.1 V, I _{OUT} = 1 A | | | 1 | % |
| V _{LOADREG} | Load regulation - DC ΔV _{OUT} /ΔI _{OUT} | I _{OUT} = 10 – 90% I _{OUT,MAX} | | 0.5 | | %/A |
| V _{OUTTOL} | DC set tolerance | Feedback resistor tolerance not included | -2 | | 2 | % |
| d | Duty cycle ⁽⁵⁾ | | 15 | | 85 | % |
| A _{MOD} | Modulator gain | | | 5 | | |
| f _{SW} | Switching frequency | | | 1 | | MHz |
| C _{OUT} | Output capacitance | | 10 ⁽³⁾ | 47 | | μF |
| ESR | Capacitor ESR | | | | 50 | mΩ |
| L | Nominal inductance | | | 2.2 | | μH |
| BUCK3 | | | | | | |
| V _{OUT} | Output voltage range ⁽⁴⁾ | | 0.9 | | 3.3 | V |
| PG | Power good threshold | V _{OUT} rising | | 95 | | % |
| UVD | Under voltage detect | V _{OUT} falling | | 75 | | % |

(2) Performance outside these limits is not guaranteed.

(3) Absolute value. User should make allowances for tolerance and variations due to component selection.

(4) Output voltage range is limited by the minimum and maximum duty cycle. V_{OUT(min)} ~ d(min) × V_{INPUT} and V_{OUT(max)} ~ d(max) × V_{INPUT}.

(5) Performance outside these limits is not guaranteed.

ELECTRICAL CHARACTERISTICS (continued)

 VIN = 12 V ±5%, VINB2, VINB3 = 5 V ±5%, VINU = 5 V ±5% T_J = 0°C to 150°C, unless otherwise noted.

| PARAMETER | | TEST CONDITIONS | MIN | TYP | MAX | UNIT |
|-------------------------------------|--|--|-----|-------|-----|------|
| | PG glitch rejection | | | 50 | | μs |
| V _{FB} | Feedback voltage | | -2% | 0.804 | 2% | V |
| I _{OUT} | Output current | | | | 3 | A |
| η | Efficiency | I _O = 2 A, V _{OUT} = 1.2 V | | 86 | | % |
| R _{DS(ON)} | Low-side MOSFET On resistance | VIN12V = 12 V | | 32 | | mΩ |
| | High-side MOSFET On resistance | | | 36 | | |
| I _{LIMIT} | Switch current limit | | | 5 | | A |
| | Current limit accuracy | | -30 | | 30 | % |
| V _{LINEREG} | Line regulation - DC ΔV _{OUT} /ΔVINB | VINB = 4.75 V - 6.1 V, I _{OUT} = 1000 mA | | | 1 | % |
| V _{LOADREG} | Load regulation - DC ΔV _{OUT} /ΔI _{OUT} | I _{OUT} = 10 – 90% I _{OUT,MAX} | | 0.5 | | %/A |
| V _{OUTTOL} | DC Set Tolerance | Feedback resistor tolerance not included | -2 | | 2 | % |
| d | Duty cycle ⁽⁵⁾ | | 15 | | 85 | % |
| A _{MOD} | Modulator gain | | | 5 | | |
| f _{SW} | Switching frequency | | | 1 | | MHz |
| C _{OUT} | Output capacitance | | 10 | | | μF |
| ESR | Capacitor ESR | | | | 50 | mW |
| L | Nominal inductance | | | 2.2 | | μH |
| SOFT START (BUCK1, 2, and 3) | | | | | | |
| I _{SS} | Soft start current source | | | 2 | | μA |
| V _{SS, MAX} | Soft start ramp voltage | Ramp end | | 0.8 | | V |
| C _{SS} | Soft start capacitor | t _{SS} = 0.4 ms/nF | 2 | 3.3 | 5 | nF |
| SSDONE_BK | Deglintch time | | | 2.5 | | ms |
| SSDONE_DCH | SS discharge time | | | 500 | | μs |
| SUPPLY VOLTAGE SUPERVISOR | | | | | | |
| VMON1 | Threshold voltage (VMON1) | Supply rising | | | 3.2 | V |
| | | Supply falling | 3 | | | |
| | | Hysteresis | | .05 | | |
| VMON2 | Threshold voltage (VMON2) | Supply rising | | 850 | | mV |
| | | Supply falling | | 750 | | |
| | | Hysteresis | | 20 | | |
| t _{deglitch} | Deglintch time (both edges) | | | 192 | | μs |
| V _{OL} | Reset pin output-low voltage | I _{sink} = 3.2 mA | | | 0.4 | V |
| t _{RP} | Minimum reset period | | | 180 | | ms |
| USB POWER SWITCHES | | | | | | |
| R _{DS(on)} | On resistance | | | 100 | | mΩ |
| t _r | Rise time output | VINU = 5.5 V, C _L = 120 mF, V _{OUT} 10% to 90%. | | | 1 | ms |
| t _{on} | Turn-on time | C _L = 100 μF, r _L = 10 Ω | | | 3 | ms |
| t _{off} | Turn-off time | C _L = 100 μF, r _L = 10 Ω | | | 10 | ms |
| I _{OC} | Over Current limit | TPS65230 | 0.6 | 0.8 | 1 | A |
| | Output shorted to ground | TPS65231 | 1.2 | 1.6 | 2 | |
| OC deglitch | Over current deglitch | | 4 | 8 | 15 | ms |
| THERMAL SHUTDOWN | | | | | | |
| T _{hot} | Thermal warning | | | 120 | | °C |

ELECTRICAL CHARACTERISTICS (continued)

VIN = 12 V ±5%, VINB2, VINB3 = 5 V ±5%, VINU = 5 V ±5% T_J = 0°C to 150°C, unless otherwise noted.

| | PARAMETER | TEST CONDITIONS | MIN | TYP | MAX | UNIT |
|-------------------|------------------------|-----------------|-----|-----|-----|------|
| T _{trip} | Thermal S/D trip point | | | 160 | | °C |
| T _{hyst} | Thermal S/D hysteresis | | | 20 | | °C |

SUPPLY VOLTAGE SUPERVISOR (SVS)

The supply voltage supervisor monitors two inputs, VMON1 and VMON2, and generates a reset pulse of at least 180-ms length when one or more supplies fall below their respective thresholds. All inputs are deglitched for very short dips on the supplies. The reference values for VMON1 is specified for monitoring a 3.3-V rail without the need of external components. The reference for VMON2 is set to monitor arbitrary supply voltages and require resistor dividers at the inputs.

Please note that the reset signal generated by the SVS is for external use only and has no impact on the power rails or USB switches of the TPS65230 and TPS65231.

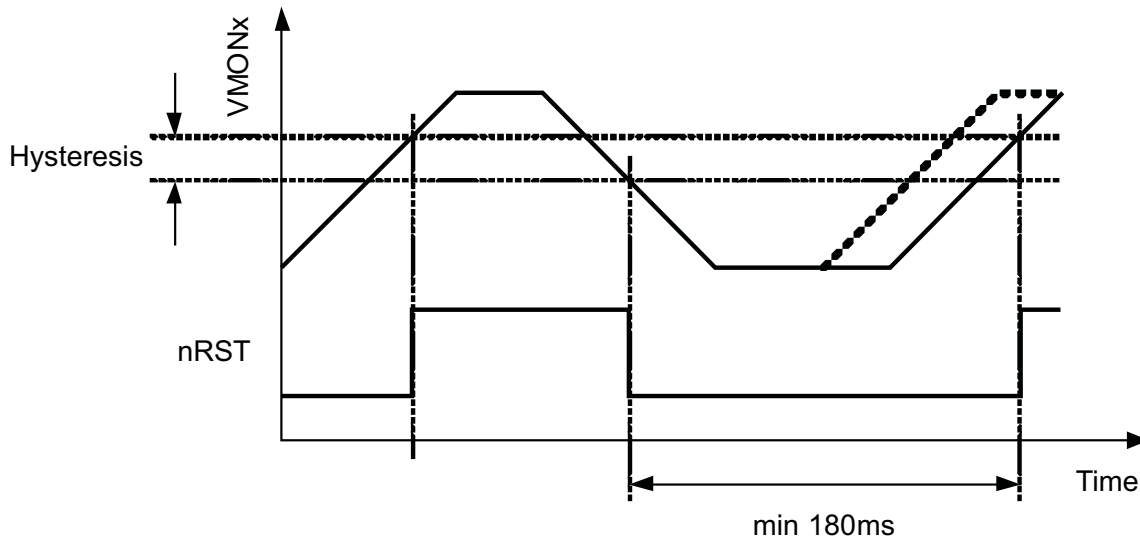

Figure 1. Supply Voltage Supervisor Reset Generation

USB POWER SWITCHES

The TPS65230 and TPS65231 provide two power-distribution switches intended for applications where heavy capacitive loads and short-circuits are likely to be encountered. Gate drive is provided by an internal regulator. Each switch is controlled by a logic enable input or, when I²C interface is enabled, switches are controlled through EN_USBx bits of the ENABLE register.

When the output load exceeds the current-limit threshold or a short is present, the device limits the output current to a safe level by switching into a constant-current mode, pulling the USBFAULTx output low. When continuous heavy overloads and short-circuits increase the power dissipation in the switch, causing the junction temperature to rise, a thermal protection circuit shuts off the switches when a thermal warning condition occurs to prevent damage. Recovery from a thermal warning is automatic once the device has cooled sufficiently. Internal circuitry ensures that the switch remains off until valid input voltage is present.

POWER-UP SEQUENCING

ON/OFF control and power sequencing of the three buck regulators is controlled through EN_BCK1, EN_BCK2, and EN_BCK3 enable pins. Each pin is internally connected to a 6-μA constant-current source and monitored by a comparator with Schmitt trigger input with defined threshold. Connecting EN_BCKn pin to ground disables BUCKn and connecting EN_BCKn to V3P3 will enable the respective buck without delay. If more than one buck enable pin is connected to V3P3 the default startup sequence is BUCK1, BUCK2, BUCK3 and the minimum startup delay between rails is the soft-start time (typical 1.5 ms) plus 1 ms.

To create a startup-sequence different from the default, capacitors are connected between the EN_BUCKn pins and ground. At power-up the capacitors are first discharged and then charged to V3P3 level by internal current sources (6 μA typical) creating a constant-slope voltage ramp. A regulator is enabled when its EN pin voltage crosses the enable threshold (typical 1.2 V). A delay of 0.2 ms is generated for each 1-nF of capacitance connected to the enable pin. If two enable pins are pulled high while the third regulator is starting up, the default sequence will be applied to enable the remaining two regulators. To override default power-up sequence it is recommended that delay times differ by more than the soft-start time (typical 1.3 ms) plus 1 ms.

In I²C mode regulators can also be enabled by setting their respective EN bits in the ENABLE register. The same startup-time limitations and arbitration rules apply in I²C mode as described above.

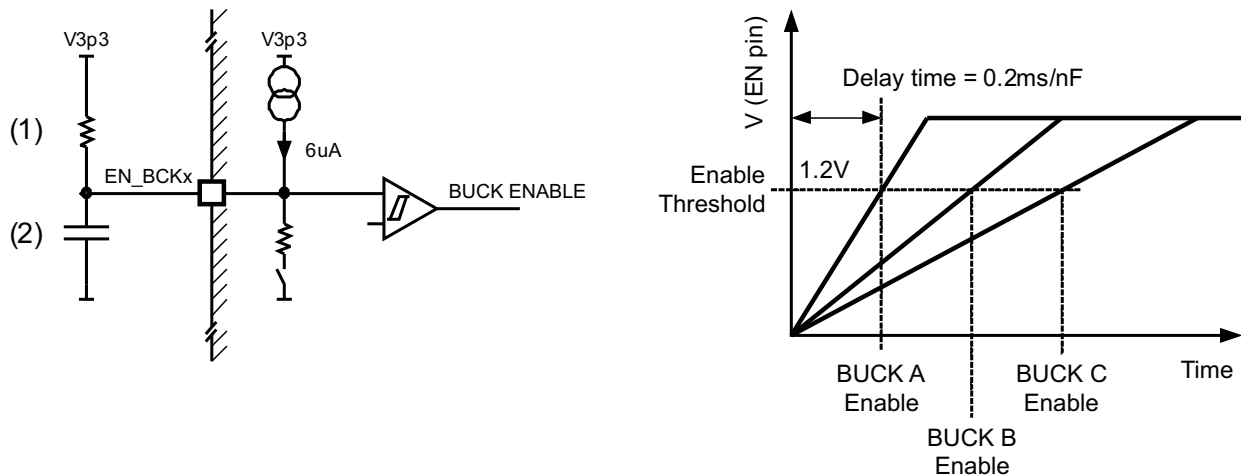

- (1) Connect EN_BCKx pin to V3P3 to follow the default power-up sequence or
- (2) Connect a capacitor from EN_BCKx to GND to generate a custom power-up sequence.

Figure 2. Customizing the Power-Up Sequence

OVER CURRENT PROTECTION

Over current protection (OCP) for BUCK1 is achieved by comparing the drain-to-source voltage of the low-side MOSFET to a set-point voltage, which is defined by both the internal current source, I_{TRIP} , and the external resistor connected between the TRIP pin and ground. Over current threshold is calculated as Equation 1.

$$I_{LIM} = \frac{R_{TRIP} \cdot I_{TRIP}}{10 \cdot R_{DS(ON)}} \quad (1)$$

I_{TRIP} has a typical value of 10 μA at 25°C and a temperature coefficient of 3700 ppm/°C to compensate the temperature dependency of the MOS $R_{DS(ON)}$. The TPS65230 and TPS65231 support cycle-by-cycle over current limiting control which means that the controller compares the drain-to-source voltage of the low-side FET to the set-point voltage once per switching cycle and blanks out the next switching cycle if an over-current condition is detected. If in the following cycle over current condition is detected again, the controller blanks out 2, then 4, 8, and up to 16 cycles before turning on the high-side driver again. In an over current condition the current to the load exceeds the current to the output capacitor thus the output voltage will drop, and eventually cross the under

voltage protection threshold and shut down the BUCK controller. Buck 2 and 3 show a similar mode of operation. All converters operate in hiccup mode: Once an over-current is sensed, the controller shuts off the converter for a given time and then tries to start again. If the overload has been removed, the converter will ramp up and operate normally. If this is not the case the converter will see another over-current event and shuts-down again repeating the cycle (hiccup) until the failure is cleared.

SOFT START

Soft start (SS) for all three BUCKs is controlled by a single capacitor connected to the SS pin and an internal current source. When one of the BUCKs is enabled, the SS capacitor is pre-charged to the output voltage divided by the feed-back ratio before the internal SS current source starts charging the external capacitor. The output voltage of the BUCK ramps up as the SS pin voltage increased from its pre-charged value to 0.8 V. The soft start time is calculated from the SS supply current (ISS) and the capacitor value and has a typical value of 0.4 ms/nF or 1.3 ms for a 3.3-nF capacitor connected to the SS pin. Before the next rail is enabled, the SS cap is discharged and the SS cycle starts over again.

BROWNOUT MONITOR (BOR)

The TPS65230 and TPS65231 monitor the input supply and issues a warning if the input voltage drops below the BOR threshold of 9.3 V. The nBOR/nHOT pin is pulled low to alarm the host processor of the brown-out condition. nBOR is released after the supply voltage has risen above 10.8 V. nBOR/nHOT pin is also pulled low when the chip temperature rises above the HOT threshold and is released when the chip has cooled off. The purpose of the nBOR/nHOT function is to give the host processor time to finish operations and store data before the system shuts down. Both events, BOR and HOT, are individually flagged in the STATUS1 register. Note that unlike the INT output pin, reading the STATUSx registers has no effect on the state of the nBOR/nHOT pin in I²C mode. nBOR/nHOT depends only of the input voltage and temperature condition.

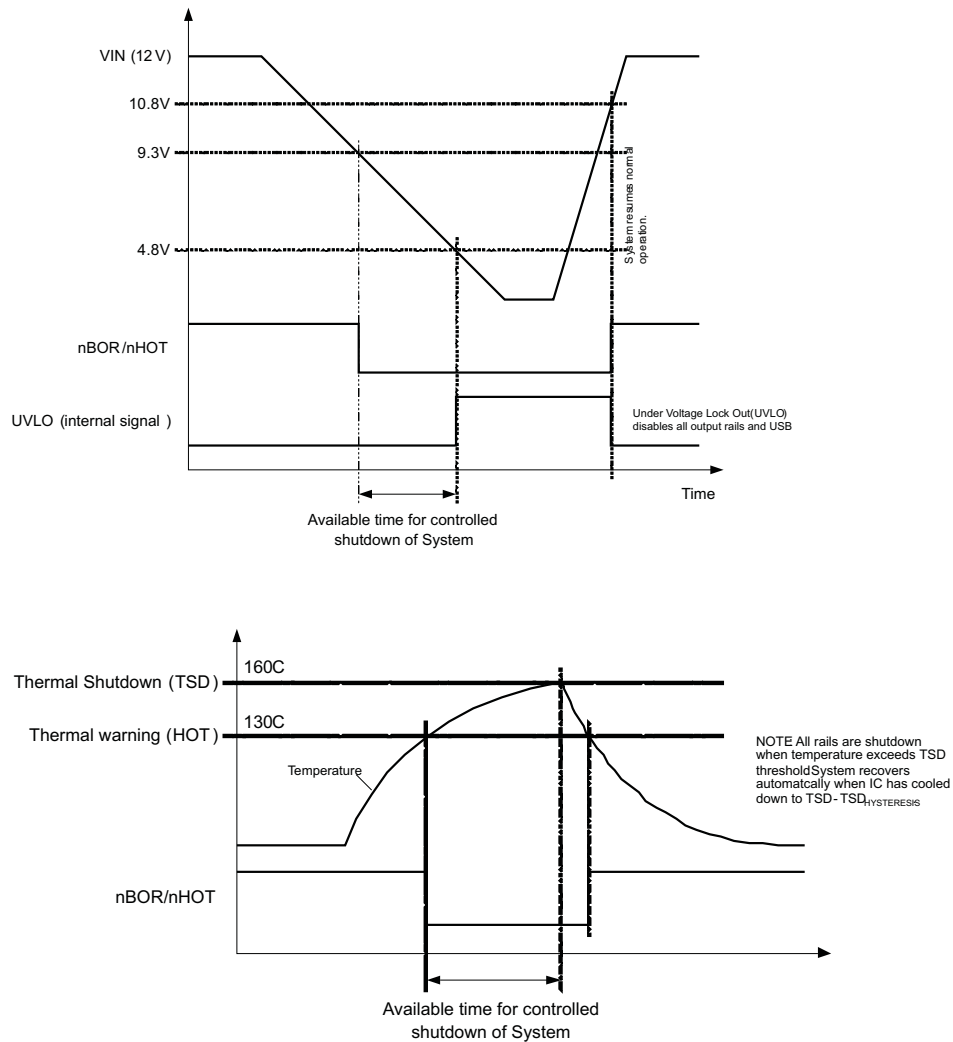

Figure 3. Brownout Monitoring

UNDER VOLTAGE LOCKOUT (UVLO)

TPS65230 and TPS65231 monitors VIN, VINB, and VINU pin voltages and will disable one or more power paths depending on the current use condition:

- If VIN drops below 9.3 V, both USB power paths are disabled and the nBOR/nHOT output pin is pulled low.
- If VIN drops below 4.7 V, BUCK1, 2, and 3 are disabled.
- If VINB drops below 4.25 V and either BUCK2 or BUCK3 are enabled, all three output rails are disabled.
- If VINU drops below 3.9V and either USB1 or USB2 are enabled, both USB switches are disabled.

UVLO state is not latched and the system recovers as soon as the input voltage rises above its respective threshold. All three BUCK_ENx pins are discharged and remain discharged during UVLO to ensure proper power sequencing when the system recovers.

In I²C mode the EN_BUCKx and EN_USBx bits of the ENABLE register are reset in an UVLO event and interrupt is issued. To re-enable the output supplies, the respective EN_BUCKx bits have to be set through the I²C interface or the BUCK_ENx pins have to be pulled high. To re-enable the USB power switches in I²C mode, the EN_USBx bits of the ENABLE register have to be set through the I²C interface.

THERMAL SHUTDOWN (TSD)

TPS65230x monitors junction temperature and will disable all power paths (BUCK1-3, USB1 and 2) if junction temperature rises above the specified trip point. nBOR/nHOT pin will be pulled low if the temperature approaches the TSD trip point within 40°C. In I²C mode the device will also issue an interrupt and set the HOT bit in STATUS1 register. The system recovers as soon as the temperature falls below the falling-edge trip temperature. All three BUCK_ENx pins are discharged and remain discharged during TSD to ensure proper power sequencing when the system recovers.

In I²C mode the EN_BUCKx and EN_USBx bits of the ENABLE register are reset in a TSD event and interrupt is issued. To re-enable the output supplies the respective EN_BUCKx bits have to be set through the I²C interface or the BUCK_ENx pins have to be pulled high. To re-enable the USB power switches in I²C mode, the EN_USBx bits of the ENABLE register have to be set through the I²C interface.

LOOP COMPENSATION

All three BUCKs are voltage mode converters designed to be stable with ceramic capacitors. Refer to Component Selection Procedure section for calculating feedback components.

3.3-V REGULATOR

The TPS6532x has a built-in 3.3-V regulator for powering internal circuitry. The 3.3-V rail can also be used for enabling the BUCK regulators and/or the USB switches, but is not intended for supplying any other external circuitry. For light loading of this rail during stand-by operation consult TI FAE.

6-V REGULATOR

The TPS6532x has a built-in 6-V regulator for powering internal circuitry. The 6-V rail can also be used for enabling I²C functionality by connecting the pull-up resistor on the USBFLG2/nINT pin to V6V but is not intended for supplying any other external circuitry. For light loading of this rail during stand-by operation consult TI FAE.

USER SELECTABLE SERIAL INTERFACE

TPS65230 and TPS65231 feature an I²C slave interface which can be enabled or disabled by the user and offers advanced control and diagnostic features. I²C control is enabled when the pull-up resistor on the USBFLG2/nINT pin is connected to a supply voltage > 4.5 V and is disabled otherwise. When disabled, BUCK1, 2, 3, and USB1, 2 are controlled through their respective enable pins. When the I²C interface is enabled, USB1 and USB2 are controlled through the serial interface and BUCK1, 2, and 3 are controlled either through the serial interface or their respective enable pins. In addition, the USBFLG1/VCTRL pin is reconfigured when I²C is enabled to offer output voltage control for BUCK2 and BUCK3.

I²C operation offers brownout and thermal shutdown warning, thermal shut down flag, power-good and under-voltage indicator for BUCK1-3 and USB fault indicator for both USB switches. Whenever a fault is detected, the associated status bit in the STATUS1 and 2 registers are set and the INT pin is pulled low. Reading of the STATUS1 and 2 registers resets the flag bits and INT pin is released after all flags have been reset. Note that in I²C mode the nINT pin is active high with voltage swing of > 3.3 V. To invert the signal and shift the voltage level down to an I/O compatible level, connect the circuit shown in [Figure 5](#) to the USBFL2/nINT pin.

INT Dependent Device Pin Configuration

| PIN NO. | DEVICE PIN | USBFLG2/INT CONNECTED TO V6V ⁽¹⁾ | USBFLG2/INT CONNECTED TO 3.3V ⁽¹⁾ |
|---------|---------------|---|--|
| 30 | USBFLG2/nINT | nINT | Error flag for USB switch 2 |
| 28 | EN_USB1/SCL | SCL (Clock) | Enable pin for USB switch 1 |
| 29 | EN_USB2/SDA | SDA (Data) | Enable pin for USB switch 2 |
| 44 | USBFLG1/VCTRL | Voltage control input for BUCK2 and 3 | Error flag for USB switch 1 |

(1) Via pull-up resistor

I²C operation also offers output voltage adjustment options for BUCK2 and BUCK3. This feature is useful to reduce power dissipation in the system by lowering the supply voltages when the system is in idle state. Output voltage can be scaled down by 5, 10 and 15% depending on the VBCKn[1:0] bit settings in the VADJUST register. Settings are activated when the USBFLG1/VCTRL pin is pulled high and are deactivated when the pin is pulled low. This allows for fast output voltage transition without involvement of the I²C interface. Alternatively the settings can be activated by setting the the VCTRLx bits of the ENABLE register.

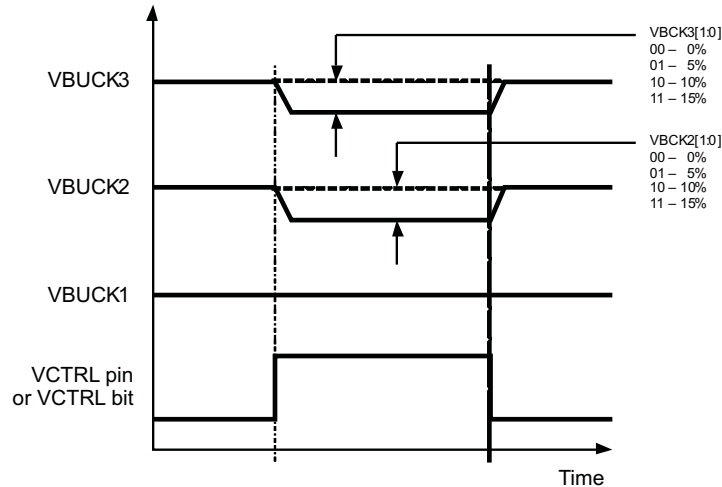

Figure 4. BUCK2 and BUCK3 Output Voltages

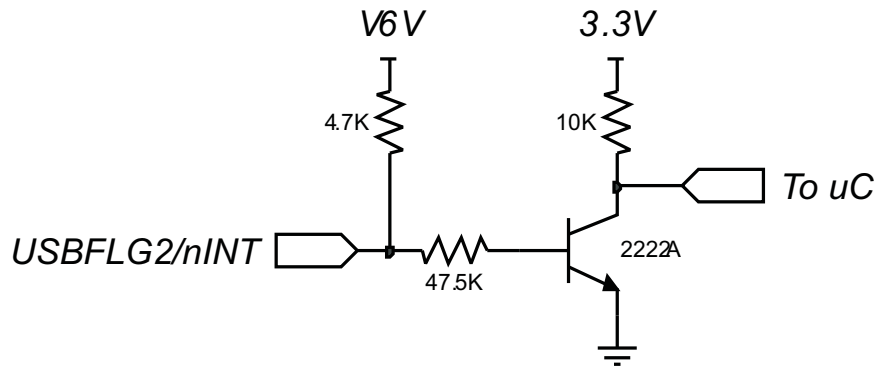

Figure 5. Circuit for Level-Shifting and Inverting nINT Signal

I²C BUS OPERATION

The TPS65230 hosts a slave I²C interface that supports data rates up to 400 kbit/s and auto-increment addressing and is compliant to I²C standard 3.0.

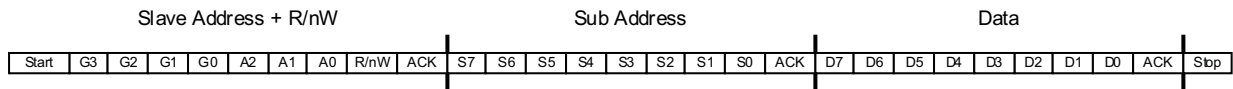

Figure 6. Subaddress in I²C Transmission

- Start — Start condition
- G(3:0) — Group ID: 1001
- A(2:0) — Device address: 000
- R/nW — Read/not write select bit

- ACK** — Acknowledge
- S(7:0)** — Subaddress: defined per register map
- D(7:0)** — Data: data to be loaded into the device
- Stop** — Stop condition

The I²C Bus is a communications link between a controller and a series of slave terminals. The link is established using a two-wired bus consisting of a serial clock signal (SCL) and a serial data signal (SDA). The serial clock is sourced from the controller in all cases where the serial data line is bi-directional for data communication between the controller and the slave terminals. Each device has an open drain output to transmit data on the serial data line. An external pull-up resistor must be placed on the serial data line to pull the drain output high during data transmission.

Data transmission is initiated with a start bit from the controller as shown in Figure 7. The start condition is recognized when the SDA line transitions from high to low during the high portion of the SCL signal. Upon reception of a start bit, the device will receive serial data on the SDA input and check for valid address and control information. If the appropriate group and address bits are set for the device, then the device will issue an acknowledge pulse and prepare the receive subaddress data. Subaddress data is decoded and responded to as per the Register Map section of this document. Data transmission is completed by either the reception of a stop condition or the reception of the data word sent to the device. A stop condition is recognized as a low to high transition of the SDA line during the high portion of the SCL signal. All other transitions of the SDA line must occur during the low portion of the SCL signal. An acknowledge is issued after the reception of valid address, sub-address and data words. The I²C interface will auto-sequence through register addresses, so that multiple data words can be sent for a given I²C transmission. Reference Figure 7.

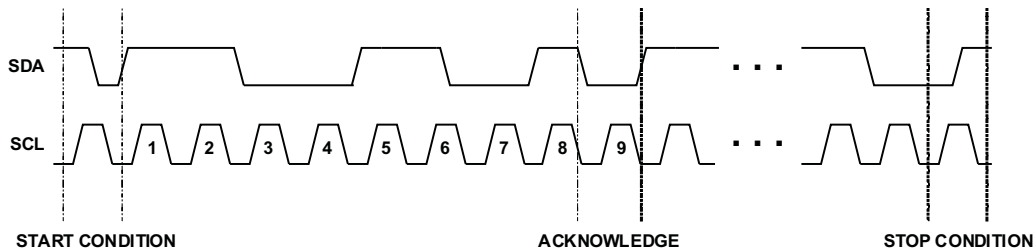

Figure 7. I²C Start / Stop / Acknowledge Protocol

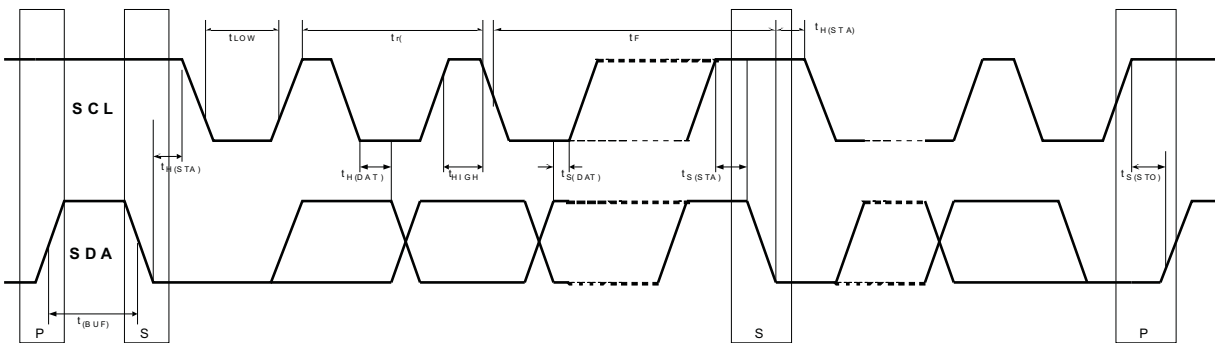

Figure 8. I²C Data Transmission Timing

DATA TRANSMISSION TIMING

 VBUS = 3.6 V ±5%, T_A = 25 °C, C_L = 100 pF (unless otherwise noted)

| PARAMETER | | TEST CONDITIONS | MIN | MAX | UNIT |
|---------------------|--|-----------------|-----|------|------|
| f _(SCL) | Serial clock frequency | SCL = 100 kHz | | 100 | kHz |
| | | SCL = 400 kHz | | 400 | |
| t _(BUF) | Bus free time between stop and start condition | SCL = 100 kHz | 4.7 | | μs |
| | | SCL = 400 kHz | 1.3 | | |
| t _(SP) | Tolerable spike width on bus | SCL = 100 kHz | | 50 | ns |
| | | SCL = 400 kHz | | | |
| t _{LOW} | SCL low time | SCL = 100 kHz | 4.7 | | μs |
| | | SCL = 400 kHz | 1.3 | | |
| t _{HIGH} | SCL high time | SCL = 100 kHz | 4 | | μs |
| | | SCL = 400 kHz | 0.6 | | |
| t _{S(DAT)} | SDA → SCL setup time | SCL = 100 kHz | 250 | | ns |
| | | SCL = 400 kHz | 100 | | |
| t _{S(STA)} | Start condition setup time | SCL = 100 kHz | 4.7 | | μs |
| | | SCL = 400 kHz | 0.6 | | |
| t _{S(STO)} | Stop condition setup time | SCL = 100 kHz | 4 | | μs |
| | | SCL = 400 kHz | 0.6 | | |
| t _{H(DAT)} | SDA → SCL hold time | SCL = 100 kHz | | 3.45 | μs |
| | | SCL = 400 kHz | | 0.9 | |
| t _{H(STA)} | Start condition hold time | SCL = 100 kHz | 4 | | μs |
| | | SCL = 400 kHz | 0.6 | | |
| t _{r(SCL)} | Rise time of SCL signal | SCL = 100 kHz | | 1000 | ns |
| | | SCL = 400 kHz | | 300 | |
| t _{f(SCL)} | Fall time of SCL signal | SCL = 100 kHz | | 300 | ns |
| | | SCL = 400 kHz | | 300 | |
| t _{r(SDA)} | Rise time of SDA signal | SCL = 100 kHz | | 1000 | ns |
| | | SCL = 400 kHz | | 300 | |
| t _{f(SDA)} | Fall time of SDA signal | SCL = 100 kHz | | 300 | ns |
| | | SCL = 400 kHz | | 300 | |

THERMAL MANAGEMENT AND SAFE OPERATING AREA

Total power dissipation inside TPS6523x is limited not to exceed the maximum allowable junction temperature of 150°C. The maximum allowable power dissipation is a function of the thermal resistance of the package (θ_{JA}) and ambient temperature. θ_{JA} itself is highly dependent on board layout. The maximum allowable power inside the IC for operation at maximum ambient temperature without exceeding the temperature warning flag using the JEDEC High-K board is calculated as [Equation 3](#).

$$\Delta T = \theta_{JA} \cdot P \quad (2)$$

$$P_{MAX} = \frac{T_{MAX} - T_{ambient}}{\theta_{JA}} = \frac{120^{\circ}\text{C} - 55^{\circ}\text{C}}{25^{\circ}\text{C}/\text{W}} \approx 2.6 \text{ W} \quad (3)$$

For different PCB layout arrangements the thermal resistance (θ_{JA}) will change as the following table shows.

| BOARD TYPE | STACK-UP | θ _{JA} |
|-------------------------------|--|-----------------|
| 8" x 10" FR4 PCB, four layers | 1.5-oz Cu, 60% Cu coverage top layer, 80% Cu coverage bottom layer, no airflow 0.5-oz 30%Cu coverage inner layers | 29 |
| 8" x 10" FR4 PCB, two layers | 1-oz Cu, 20% Cu coverage top layer, 90% Cu coverage bottom layer, no airflow | 44 |

A minimum of two layers of 1-oz Cu with 20% Cu coverage on the top and 90% coverage on the bottom and the use of thermal vias to connect the thermal pad to the bottom layer is recommended. Note that the maximum allowable power inside the device will depend on the board layout. For recommendations on board layout for thermal management using TPS6523x consult your TI field application engineer.

In the example shown above the maximum allowable power dissipation for the IC has been calculated. This figure includes all heat sources inside the device including the power dissipated in BUCK1, BUCK2, BUCK3, USB switches, and all supporting circuitry. Power dissipated in BUCK1, USB switches (500 mA full load) , and all supporting circuitry is approximately 0.4 W and almost independent of the application. Power dissipated in BUCK2 and BUCK3 depends on the output voltage, output current, and efficiency of the switching converters. The following examples of safe operating area assume 90% efficiency for BUCK2 and BUCK3, 3.3-V output from BUCK3 and 1.2-V, 1.8-V, and 2.5-V output from BUCK2, respectively.

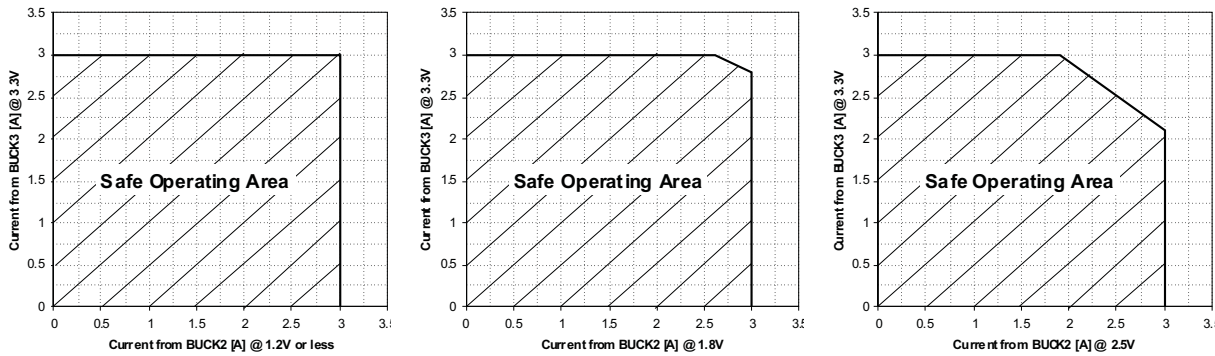

For any voltage / current combination inside the shaded area, the dissipated power inside the chip is below the allowable maximum. The examples assume $T_{ambient} < 60^{\circ}C$, $\eta = 90\%$ and $\theta_{JA} < 44^{\circ}C/W$.

Figure 9. Examples of Thermal Safe Operating Area for $V(BUCK3) = 3.3 V$ and $V(BUCK1) = 1.2 V, 1.8 V$ and $2.5 V$, Respectively

COMPONENT SELECTION PROCEDURE

The following example illustrates the design procedure for selecting external components for the three buck converters. The example focuses on BUCK1 but the procedure can be directly applied to BUCK2 and 3 as well. The design goal parameters are given in the table below. A list of symbol definitions is found at the end of this section. For this example the schematic in Figure 10 will be used.

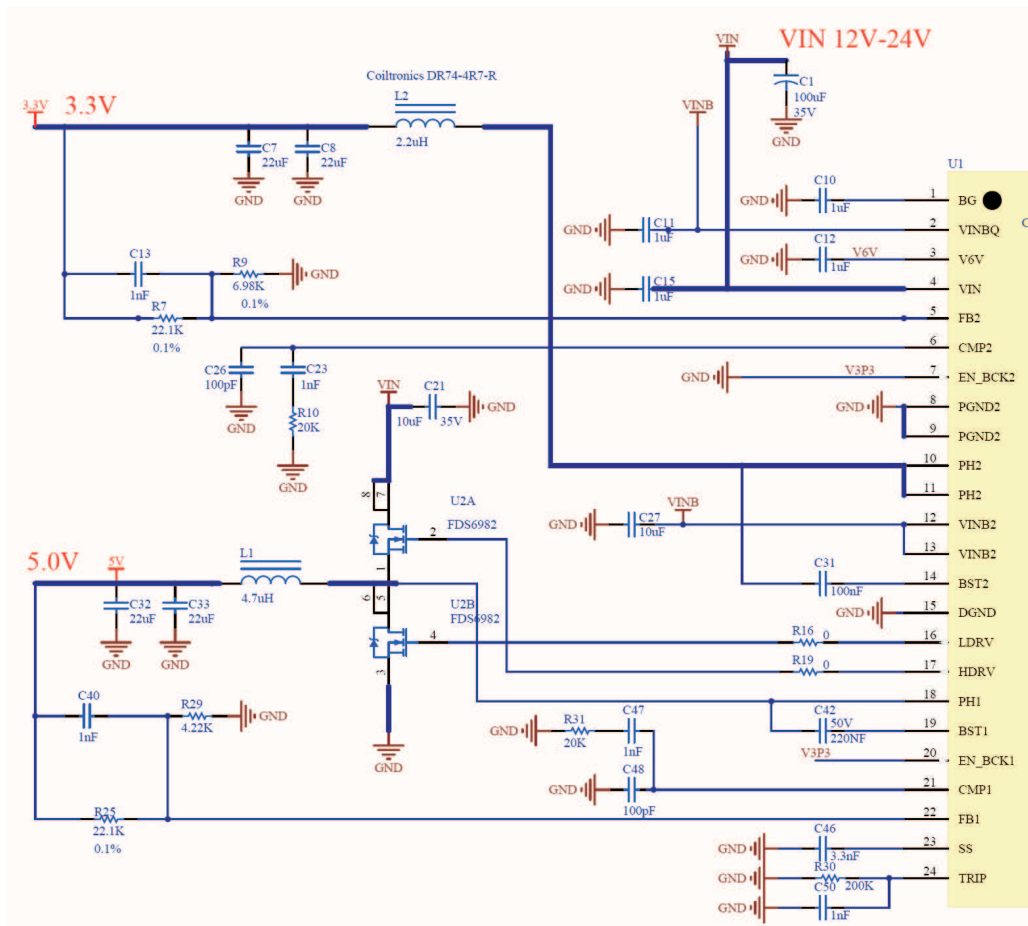

Figure 10. Sample Schematic for TPS6523x Showing Components Relevant to BUCK1

| PARAMETER | TEST CONDITIONS | MIN | TYP | MAX | UNIT |
|-------------------------|----------------------|--------------------------------------|-----|------|------|
| V _{IN} | Input supply voltage | 10.8 | 12 | 13.2 | V |
| V _{IN} RIPPLE | Input voltage ripple | I _{OUT, BUCK1} = 6 A | | 60 | mV |
| V _{OUT} | Output Voltage | 4.75 | 5 | 5.25 | V |
| | Line regulation | V _{IN} = 10.8 V to 13.2 V | | 25 | mV |
| | Load regulation | I _{OUT, BUCK1} = 0 A to 6 A | | 25 | mV |
| V _{OUT} RIPPLE | Output ripple | I _{OUT, BUCK1} = 6 A | | 50 | mV |
| V _{TRANS} | Transient deviation | I _{OUT, BUCK1} = 2 A to 6 A | | 125 | mV |
| I _{OUT} | Output current | V _{IN} = 10.8 V to 13.2 V | | 0 | A |
| f _{SW} | Switching frequency | | | 500 | kHz |

INDUCTOR SELECTION

For BUCK1 the recommended inductor value is 4.7 μH and for BUCK2 and 3 it is 2.2 μH. These values will provide a good balance between ripple current, efficiency, loop bandwidth and inductor cost. The inductor is typically sized for < 30% peak-to-peak ripple current (I_{ripple}). Given this target ripple current, the required inductor size is calculated by Equation 4.

$$L = \frac{V_{IN(MAX)} - V_{OUT}}{0.3 \cdot I_{OUT}} \cdot \frac{V_{OUT}}{V_{IN(MAX)}} \cdot \frac{1}{f_{SW}} \quad (4)$$

Solving Equation 4 with V_{IN(MAX)} = 13.2 V, an inductor value of 3.5 μH is obtained. A standard value of 4.7 μH is selected, resulting in 1.25-A peak-to-peak ripple. The RMS current through the inductor is approximated by Equation 5.

$$I_{L(RMS)} = \sqrt{\left(I_{L(avg)}\right)^2 + \frac{1}{12}(I_{RIPPLE})^2} = \sqrt{(I_{OUT})^2 + \frac{1}{12}(I_{RIPPLE})^2} \quad (5)$$

Using [Equation 5](#), the maximum RMS current in the inductor is about 6.01 A.

OUTPUT CAPACITOR SELECTION

The selection of the output capacitor is typically driven by the output load transient response requirement. The output capacitance (base) proposed is 2 x 22 μF (or 4 X 10 μF or 1 x 47 μF) ceramic, providing a good balance between ripple, cost and performance. Extra caps added should be electrolyte or far from base cap to have considerable amount of ESR and not to affect compensation.

[Equation 6](#) and [Equation 7](#) estimate the output capacitance required for a given output voltage transient deviation.

$$C_{OUT(MIN)} = \frac{I_{TRAN(MAX)}^2 \cdot L}{(V_{IN(MIN)} - V_{OUT}) \cdot V_{TRAN}} \quad \text{when } V_{IN(MIN)} < 2 \cdot V_{OUT} \quad (6)$$

$$C_{OUT(MIN)} = \frac{I_{TRAN(MAX)}^2 \cdot L}{V_{OUT} \cdot V_{TRAN}} \quad \text{when } V_{IN(MIN)} > 2 \cdot V_{OUT} \quad (7)$$

For this example, [Equation 7](#) is used in calculating the minimum output capacitance.

Based on a 4-A load transient with a maximum 125-mV deviation (2.5% of set voltage), a minimum of 120-μF output capacitance is required. We choose two 22-μF ceramic capacitors and two electrolytic 47 μF in parallel for a total capacitance of 138 μF.

The output ripple is divided into two components. The first is the ripple generated by the inductor ripple current flowing through the output capacitor's capacitance, and the second is the voltage generated by the ripple current flowing in the output capacitor's ESR. The maximum allowable ESR is then determined by the maximum ripple voltage and is approximated by [Equation 8](#).

$$ESR_{MAX} = \frac{V_{RIPPLE(total)} - V_{RIPPLE(cap)}}{I_{RIPPLE}} = \frac{V_{RIPPLE(total)} - \left(\frac{I_{RIPPLE}}{C_{OUT} \cdot f_{SW}}\right)}{I_{RIPPLE}} \quad (8)$$

Based only on the 138-μF of capacitance, 1.25-A ripple current, 500-kHz switching frequency and a design goal of 50-mV ripple voltage (1% of set voltage), we calculate a capacitive ripple component of 18 mV and a maximum ESR of 25 mΩ. The X5R ceramic capacitors selected provide significantly less than 25-mΩ of ESR.

PEAK CURRENT RATING OF THE INDUCTOR

With output capacitance known, it is now possible to calculate the charging current during start-up and determine the minimum saturation current rating of the inductor. The start-up charging current is approximated by [Equation 9](#).

$$I_{CHARGE} = \frac{V_{OUT} \cdot C_{OUT}}{T_{SS}} \quad (9)$$

Using the TPS65230 and TPS65231's recommended 1.3-ms soft-start time, $C_{OUT} = 188 \mu\text{F}$ and $V_{OUT} = 5 \text{ V}$, I_{CHARGE} is found to be 720 mA. The peak current rating of the inductor is now found by [Equation 10](#).

$$I_{L(PEAK)} = I_{OUT(MAX)} + \frac{1}{2} I_{RIPPLE} + I_{CHARGE} \quad (10)$$

For this example an inductor with a peak current rating of 7.3 A is required. Note however that the inductor will need to withstand the current limit figure without a major reduction of its rated inductance.

INPUT CAPACITOR SELECTION

The input voltage ripple is divided between capacitance and ESR. For this design, $V_{RIPPLE(cap)} = 60 \text{ mV}$ (0.5% of supply) and $V_{RIPPLE(ESR)} = 30 \text{ mV}$ (0.25% of supply). The minimum capacitance and maximum ESR are estimated by [Equation 11](#) and [Equation 12](#).

$$C_{IN(MIN)} = \frac{I_{LOAD} \cdot V_{OUT}}{V_{RIPPLE(cap)} \cdot V_{IN} \cdot f_{SW}} \quad (11)$$

$$ESR_{MAX} = \frac{V_{RIPPLE(ESR)}}{I_{LOAD} + \frac{1}{2} I_{RIPPLE}} \quad (12)$$

For this design, $C_{IN} > 8 \mu\text{F}$ and $ESR < 4 \text{ m}\Omega$. The RMS current in the output capacitors is estimated by [Equation 13](#).

$$I_{RMS(CIN)} = I_{IN(RMS)} - I_{IN(avg)} = \sqrt{\left(I_{OUT}\right)^2 + \frac{1}{12} \left(I_{RIPPLE}\right)^2} \cdot \frac{V_{OUT}}{V_{IN}} - \frac{V_{OUT} \cdot I_{OUT}}{V_{IN}} \quad (13)$$

With $V_{IN} = V_{IN(MAX)}$, the input capacitors must support a ripple current of 1.4-A RMS. It is important to check the DC bias voltage de-rating curves to ensure the capacitors provide sufficient capacitance at the working voltage. Typically a 10- μF capacitor per converter is used. These capacitors should be placed as close as possible to the VINB2 and VINB3 pins (BUCK2 and BUCK3) and to the external MOSFET arrangement for BUCK1.

BOOTSTRAP CAPACITOR

To ensure proper charging of the high-side MOSFET gate, limit the ripple voltage on the bootstrap capacitor to < 5% of the minimum gate drive voltage.

$$C_{BOOST} = \frac{20 \cdot Q_{GS, HSD}}{V_{IN(MIN)}} \quad (14)$$

Based on the FDS6982 MOSFET with a maximum total gate charge of 26 nC, calculate a minimum of 80-nF of capacitance. A standard value of 220 nF is selected for BUCK1 and 100 nF for BUCK2.

SHORT CIRCUIT PROTECTION (BUCK1 ONLY)

The TPS65230 and TPS65231 uses the forward drop across the low-side MOSFET during the OFF time to measure the inductor current. The voltage drop across the low-side MOSFET is given by [Equation 15](#).

$$V_{DS} = I_{L(PEAK)} \cdot R_{DS(ON, LSD)} \quad (15)$$

When $V_{IN} = 10.8 \text{ V}$ to 13.2 V , $I_{PEAK} = 7.4\text{A}$ for full load (6 A). Using the FDS6982 MOSFET with a $R_{DS(ON, MAX)}$ at $T_J = 25^\circ\text{C}$ of $20 \text{ m}\Omega$ we calculate the peak voltage drop to be 148 mV. Adding a 50% margin to include inductor variations and overload margin, the drop voltage for trip is set at 210 mV. Solving [Equation 1](#) for R_{TRIP} and using $I_{TRIP} = 10 \mu\text{A}$:

$$R_{TRIP} = R_{DS(ON)} \cdot I_{LIM} \cdot 10^6 \quad (16)$$

We calculate a trip resistor value of 210 k Ω . Place a 1-nF capacitor parallel to R9. Please note that typical FET $R_{DS(ON)}$ is specified at 10 m Ω . Since we used $R_{DS(ON, MAX)}$, for setting the current limit, the actual current flowing through the inductor with a nominal FET can be higher than the peak current of 7.4 A before the current limit kicks in. Make sure that the chosen inductor has the correct peak current capabilities.

SHORT CIRCUIT PROTECTION (BUCK2 AND 3 ONLY)

Current limits for BUCK2 and 3 are internally set to 5 A.

FEEDBACK LOOP DESIGN

For the TPS6523x, the switching frequency and nominal output filter combination have been chosen to be 0.5 MHz 4.7 $\mu\text{H}/\sim 40 \mu\text{F}$ for BUCK1 and 1 MHz 2.2 $\mu\text{H}/\sim 40 \mu\text{F}$ for BUCK2 and 3 respectively. These values were seen as a good compromise between efficiency and small solution size. The bandwidth has been chosen to be around 1/8th - 1/11th of the switching frequency to maximize transient response whilst retaining low noise sensitivity. As indicated before it is required that the output capacitor is ceramic and further that the very low ESR causes it's associated zero to be at or above the bandwidth of the converter.

The control loop for the TPS6523x has an internal mid- to high-frequency zero-pole pair to compensate the resonant pole caused by the output L-C filter. The maximum phase boost occurs at the geometric mean of the pole zero arrangement and therefore aimed to be equal to the desired bandwidth. The pole limits the gain at high frequencies to reduce noise sensitivity and it is about 5 times higher than the zero located at ~45 kHz.

The COMP pin of the buck converters is the output of an integrator Used to get high DC accuracy. The integrator also takes care of any offsets in the zero-pole pair amplifier and the summing comparator inside the device. Also a feed-forward loop is added to the attenuator circuit.

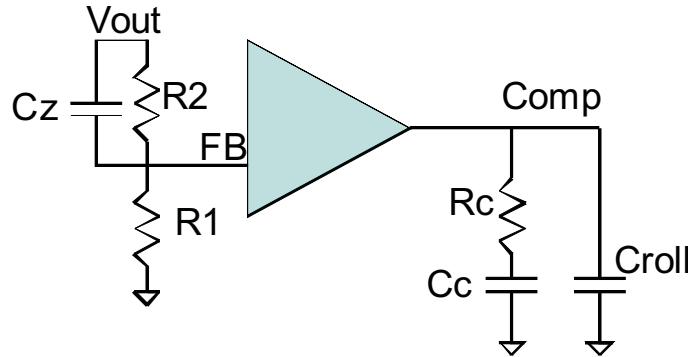

Figure 11. External Compensation Circuit

The procedure to set the integrator values is very simple (see [Figure 11](#)):

1. Set the feed-forward circuit making $R_2 = 20 \text{ k}\Omega$, $C_z = 1 \text{ nF}$.
2. Calculate R_1 as per output voltage requirement. Select R_{25} between $10 \text{ k}\Omega$ and $100 \text{ k}\Omega$. For this design select $22.1 \text{ k}\Omega$, 0.1% resistor for the upper side of all dividers. Next, R_{29} is selected to produce the desired output voltage when $V_{FB} = 0.8 \text{ V}$ using [Equation 17](#).

$$R_{29} = \frac{V_{FB} \cdot R_{25}}{V_{OUT} - V_{FB}} \quad (17)$$

$V_{FB} = 0.8 \text{ V}$ and $R_{25} = 22.1 \text{ k}\Omega$ for $V_{OUT} = 5.0 \text{ V}$, $R_{29} = 4.209 \text{ k}\Omega$. The closest value $4.22 \text{ k}\Omega$.

3. Set the integrator values, $R_C = 20 \text{ k}\Omega$, $C_C = 1 \text{ nF}$.
4. Make $C_{roll} = 100 \text{ pf}$ to roll-off gain at high frequencies.
5. If V_{IN} is ~20 - 24 V use 200 pF for C_{roll} on DCDC1.

Other Components

A 1- μF ceramic capacitor should be connected as close as possible to the following pins:

- BG (pin 1): Bandgap reference
- VIN (pin 4): Bypass capacitor (higher values are acceptable)
- V6V (pin 3): Internal 6 V supply
- V3P3 (pin 25): Internal 3.3 V supply

Register Address Map

| REGISTER | ADDRESS (HEX) | NAME | DEFAULT VALUE | DESCRIPTION |
|----------|---------------|---------|---------------|-----------------------------|
| 0 | 00 | ENABLE | 0000 0000 | Enable control register |
| 1 | 01 | VADJUST | 0000 0000 | Voltage adjustment register |
| 2 | 02 | STATUS1 | 0000 0000 | Status bit register |
| 3 | 03 | STATUS2 | 0000 0000 | Status bit register |

ENABLE Register (ENABLE), Address - 0X00H

| DATA BIT | D7 | D6 | D5 | D4 | D3 | D2 | D1 | D0 |
|-------------|----------|----------|-------|---------|---------|---------|---------|---------|
| FIELD NAME | Not used | Not used | VCTRL | EN_BCK1 | EN_BCK2 | EN_BCK3 | EN_USB1 | EN_USB2 |
| READ/WRITE | R/W | R/W | R/W | R/W | R/W | R/W | R/W | R/W |
| RESET VALUE | 0 | 0 | 0 | 0 | 0 | 0 | 0 | 0 |

| FIELD NAME ⁽¹⁾ | BIT DEFINITION |
|---------------------------|--|
| VCTRL | Voltage control bit for BUCK2 and BUCK3 0 – Nominal output voltage 1 – Enable voltage adjustment level set by VADJUST register |
| EN_BCK1 | Enable BUCK1 0 – Disabled 1 – Enabled |
| EN_BCK2 | Enable BUCK2 0 – Disabled 1 – Enabled |
| EN_BCK3 | Enable BUCK3 0 – Disabled 1 – Enabled |
| EN_USB1 | Enable USB1 0 – Disabled (OFF) 1 – Enabled |
| EN_USB2 | Enable USB2 0 – Disabled (OFF) 1 – Enabled |

(1) Enable bits EN_BCK1, EN_BCK2, and EN_BCK3 are ORed with EN_BCK1, EN_BCK2, and EN_BCK3 enable pins, respectively. To disable a block, EN bit and EN pin must be low.

VADJUST Register (VADJUST), Address - 0X01H

| DATA BIT | D7 | D6 | D5 | D4 | D3 | D2 | D1 | D0 |
|-------------|----------|----------|----------|----------|------------|-----|------------|-----|
| FIELD NAME | Not used | Not used | Not used | Not used | VBCK2[1:0] | | VBCK3[1:0] | |
| READ/WRITE | R/W | R/W | R/W | R/W | R/W | R/W | R/W | R/W |
| RESET VALUE | 0 | 0 | 0 | 0 | 0 | 0 | 0 | 0 |

| FIELD NAME ⁽¹⁾ | BIT DEFINITION |
|---------------------------|--|
| VBCK2[1:0] | BUCK2 voltage adjustment 00 - Nominal 01 - 5% Decrease 10 - 10% Decrease 11 - 15% Decrease |
| VBCK3[1:0] | BUCK3 voltage adjustment 00 - Nominal 01 - 5% Decrease 10 - 10% Decrease 11 - 15% Decrease |

(1) Voltage adjustment settings for BUCK2 and BUCK3 are effective only when VCTRL pin is pulled high or VCTRL bit of ENABLE register is set to '1'.

STATUS Register (STATUS1), Address - 0X02H

| DATA BIT | D7 | D6 | D5 | D4 | D3 | D2 | D1 | D0 |
|-------------|-----|-----|-----|------|-------|-------|---------|---------|
| FIELD NAME | BOR | TSD | HOT | UVLO | UVLOB | UVLOU | USBFLG1 | USBFLG2 |
| READ/WRITE | R | R | R | R | R | R | R | R |
| RESET VALUE | 0 | 0 | 0 | 0 | 0 | 0 | 0 | 0 |

| FIELD NAME | BIT DEFINITION ⁽¹⁾ |
|------------|---|
| BOR | Brownout. This bit is set whenever the input voltage drops below 9.3 V. |
| TSD | Thermal shutdown |
| HOT | Thermal shutdown early warning |
| UVLO | VIN under-voltage lockout |
| UVLOB | VINB under-voltage lockout |
| UVLOU | VINU under-voltage lockout |
| USBFLG1 | USB fault flag (channel1) |
| USBFLG2 | USB fault flag (channel2) |

- (1) All status bits are cleared after register read access. INT output pin will go high-impedance (open drain output) after STATUS1 and STATUS2 register have been read and / or all flags have been reset.

STATUS Register (STATUS2), Address - 0X03H

| DATA BIT | D7 | D6 | D5 | D4 | D3 | D2 | D1 | D0 |
|-------------|----------|----------|----------|----------|----------|---------|---------|---------|
| FIELD NAME | Not used | Not used | BCK1_UVD | BCK2_UVD | BCK3_UVD | BCK1_PG | BCK2_PG | BCK3_PG |
| READ/WRITE | R | R | R | R | R | R | R | R |
| RESET VALUE | 0 | 0 | 0 | 0 | 0 | 0 | 0 | 0 |

| FIELD NAME | BIT DEFINITION ⁽¹⁾ |
|------------|-------------------------------|
| BCK1_UVD | Under voltage detect, BUCK1 |
| BCK2_UVD | Under voltage detect, BUCK2 |
| BCK3_UVD | Under voltage detect, BUCK3 |
| BCK1_PG | Power Good, BUCK1 |
| BCK2_PG | Power Good, BUCK2 |
| BCK3_PG | Power Good, BUCK3 |

- (1) Bits [5:3] are cleared after register read access. INT output pin will go high-impedance (open drain output) after STATUS1 and STATUS2 register have been read and / or all flags have been reset.

PACKAGING INFORMATION

| Orderable Device | Status (1) | Package Type | Package Drawing | Pins | Package Qty | Eco Plan (2) | Lead/Ball Finish (6) | MSL Peak Temp (3) | Op Temp (°C) | Device Marking (4/5) | Samples |
|------------------|---------------|--------------|-----------------|------|-------------|-------------------------|-------------------------|----------------------|--------------|-------------------------|---------|
| TPS65230A2DCA | NRND | HTSSOP | DCA | 48 | 40 | Green (RoHS & no Sb/Br) | CU NIPDAU | Level-3-260C-168 HR | 0 to 85 | TPS65230 A2 | |
| TPS65230A2DCAR | NRND | HTSSOP | DCA | 48 | 2000 | Green (RoHS & no Sb/Br) | CU NIPDAU | Level-3-260C-168 HR | 0 to 85 | TPS65230 A2 | |
| TPS65231A2DCAR | NRND | HTSSOP | DCA | 48 | 2000 | Green (RoHS & no Sb/Br) | CU NIPDAU | Level-3-260C-168 HR | 0 to 85 | TPS65231 A2 | |

(1) The marketing status values are defined as follows:

ACTIVE: Product device recommended for new designs.

LIFEBUY: TI has announced that the device will be discontinued, and a lifetime-buy period is in effect.

NRND: Not recommended for new designs. Device is in production to support existing customers, but TI does not recommend using this part in a new design.

PREVIEW: Device has been announced but is not in production. Samples may or may not be available.

OBSOLETE: TI has discontinued the production of the device.

(2) Eco Plan - The planned eco-friendly classification: Pb-Free (RoHS), Pb-Free (RoHS Exempt), or Green (RoHS & no Sb/Br) - please check <http://www.ti.com/productcontent> for the latest availability information and additional product content details.

TBD: The Pb-Free/Green conversion plan has not been defined.

Pb-Free (RoHS): TI's terms "Lead-Free" or "Pb-Free" mean semiconductor products that are compatible with the current RoHS requirements for all 6 substances, including the requirement that lead not exceed 0.1% by weight in homogeneous materials. Where designed to be soldered at high temperatures, TI Pb-Free products are suitable for use in specified lead-free processes.

Pb-Free (RoHS Exempt): This component has a RoHS exemption for either 1) lead-based flip-chip solder bumps used between the die and package, or 2) lead-based die adhesive used between the die and leadframe. The component is otherwise considered Pb-Free (RoHS compatible) as defined above.

Green (RoHS & no Sb/Br): TI defines "Green" to mean Pb-Free (RoHS compatible), and free of Bromine (Br) and Antimony (Sb) based flame retardants (Br or Sb do not exceed 0.1% by weight in homogeneous material)

(3) MSL, Peak Temp. - The Moisture Sensitivity Level rating according to the JEDEC industry standard classifications, and peak solder temperature.

(4) There may be additional marking, which relates to the logo, the lot trace code information, or the environmental category on the device.

(5) Multiple Device Markings will be inside parentheses. Only one Device Marking contained in parentheses and separated by a "~" will appear on a device. If a line is indented then it is a continuation of the previous line and the two combined represent the entire Device Marking for that device.

(6) Lead/Ball Finish - Orderable Devices may have multiple material finish options. Finish options are separated by a vertical ruled line. Lead/Ball Finish values may wrap to two lines if the finish value exceeds the maximum column width.

Important Information and Disclaimer: The information provided on this page represents TI's knowledge and belief as of the date that it is provided. TI bases its knowledge and belief on information provided by third parties, and makes no representation or warranty as to the accuracy of such information. Efforts are underway to better integrate information from third parties. TI has taken and

continues to take reasonable steps to provide representative and accurate information but may not have conducted destructive testing or chemical analysis on incoming materials and chemicals. TI and TI suppliers consider certain information to be proprietary, and thus CAS numbers and other limited information may not be available for release.

In no event shall TI's liability arising out of such information exceed the total purchase price of the TI part(s) at issue in this document sold by TI to Customer on an annual basis.

TAPE AND REEL INFORMATION



QUADRANT ASSIGNMENTS FOR PIN 1 ORIENTATION IN TAPE



*All dimensions are nominal

| Device | Package Type | Package Drawing | Pins | SPQ | Reel Diameter (mm) | Reel Width W1 (mm) | A0 (mm) | B0 (mm) | K0 (mm) | P1 (mm) | W (mm) | Pin1 Quadrant |
|----------------|--------------|-----------------|------|------|--------------------|--------------------|---------|---------|---------|---------|--------|---------------|
| TPS65230A2DCAR | HTSSOP | DCA | 48 | 2000 | 330.0 | 24.4 | 8.6 | 13.0 | 1.8 | 12.0 | 24.0 | Q1 |
| TPS65231A2DCAR | HTSSOP | DCA | 48 | 2000 | 330.0 | 24.4 | 8.6 | 13.0 | 1.8 | 12.0 | 24.0 | Q1 |

TAPE AND REEL BOX DIMENSIONS



*All dimensions are nominal

| Device | Package Type | Package Drawing | Pins | SPQ | Length (mm) | Width (mm) | Height (mm) |
|----------------|--------------|-----------------|------|------|-------------|------------|-------------|
| TPS65230A2DCAR | HTSSOP | DCA | 48 | 2000 | 367.0 | 367.0 | 45.0 |
| TPS65231A2DCAR | HTSSOP | DCA | 48 | 2000 | 367.0 | 367.0 | 45.0 |

MECHANICAL DATA

DCA (R-PDSO-G48)

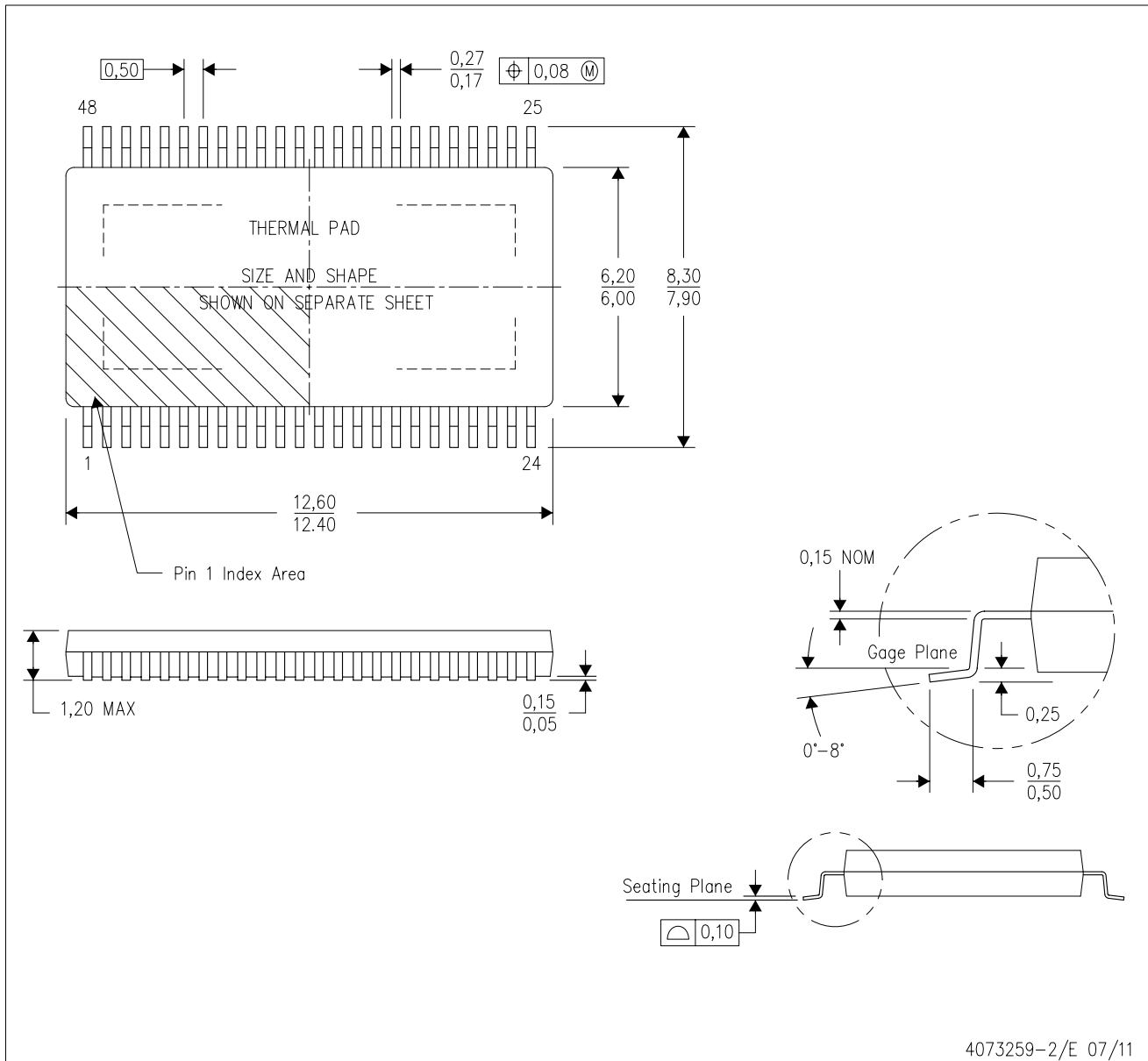
PowerPAD™ PLASTIC SMALL-OUTLINE



4073259-2/E 07/11

- NOTES:
- All linear dimensions are in millimeters. Dimensioning and tolerancing per ASME Y14.5M-1994.
 - This drawing is subject to change without notice.
 - Body dimensions do not include mold flash or protrusion not to exceed 0,15.
 - This package is designed to be soldered to a thermal pad on the board. Refer to Technical Brief, PowerPad Thermally Enhanced Package, Texas Instruments Literature No. SLMA002 for information regarding recommended board layout. This document is available at www.ti.com <<http://www.ti.com>>.
 - See the additional figure in the Product Data Sheet for details regarding the exposed thermal pad features and dimensions.
 - Falls within JEDEC MO-153

PowerPAD is a trademark of Texas Instruments.

THERMAL PAD MECHANICAL DATA

DCA (R-PDSO-G48)

PowerPAD™ PLASTIC SMALL OUTLINE

THERMAL INFORMATION

This PowerPAD™ package incorporates an exposed thermal pad that is designed to be attached to a printed circuit board (PCB). The thermal pad must be soldered directly to the PCB. After soldering, the PCB can be used as a heatsink. In addition, through the use of thermal vias, the thermal pad can be attached directly to the appropriate copper plane shown in the electrical schematic for the device, or alternatively, can be attached to a special heatsink structure designed into the PCB. This design optimizes the heat transfer from the integrated circuit (IC).

For additional information on the PowerPAD package and how to take advantage of its heat dissipating abilities, refer to Technical Brief, PowerPAD Thermally Enhanced Package, Texas Instruments Literature No. SLMA002 and Application Brief, PowerPAD Made Easy, Texas Instruments Literature No. SLMA004. Both documents are available at www.ti.com.

The exposed thermal pad dimensions for this package are shown in the following illustration.

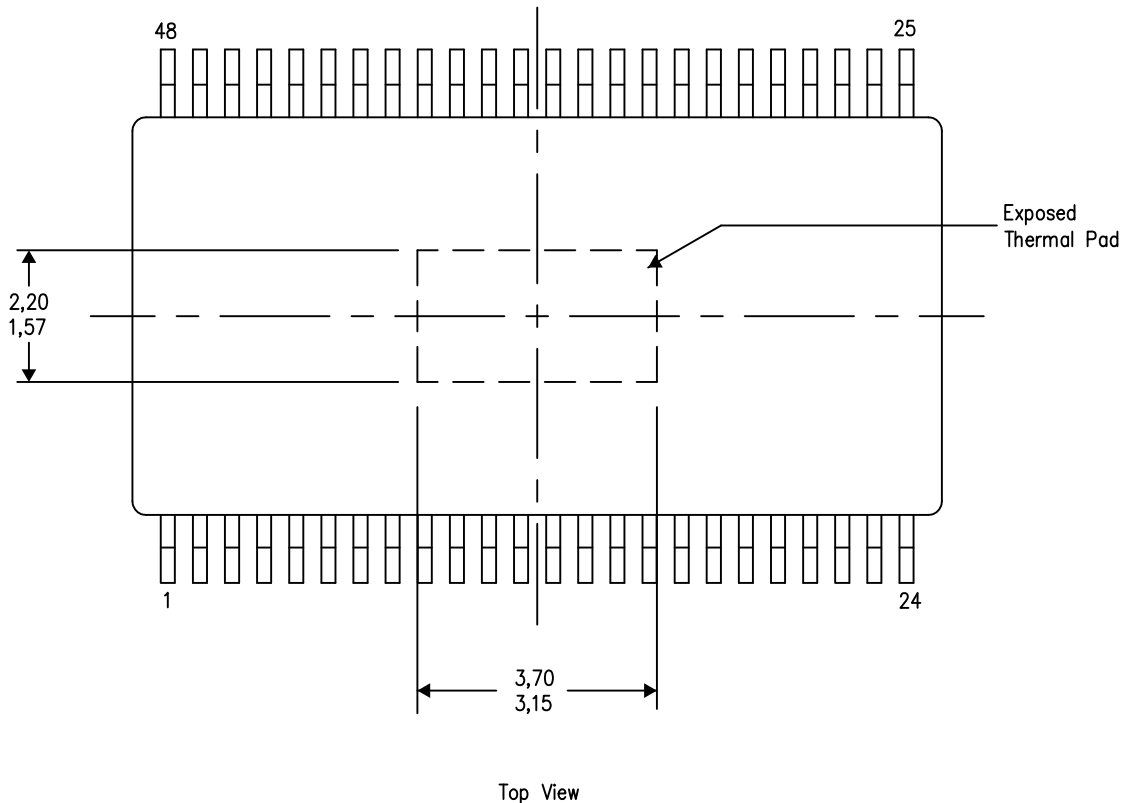

Exposed Thermal Pad Dimensions

4206320-5/S 11/14

NOTE: A. All linear dimensions are in millimeters

PowerPAD is a trademark of Texas Instruments.

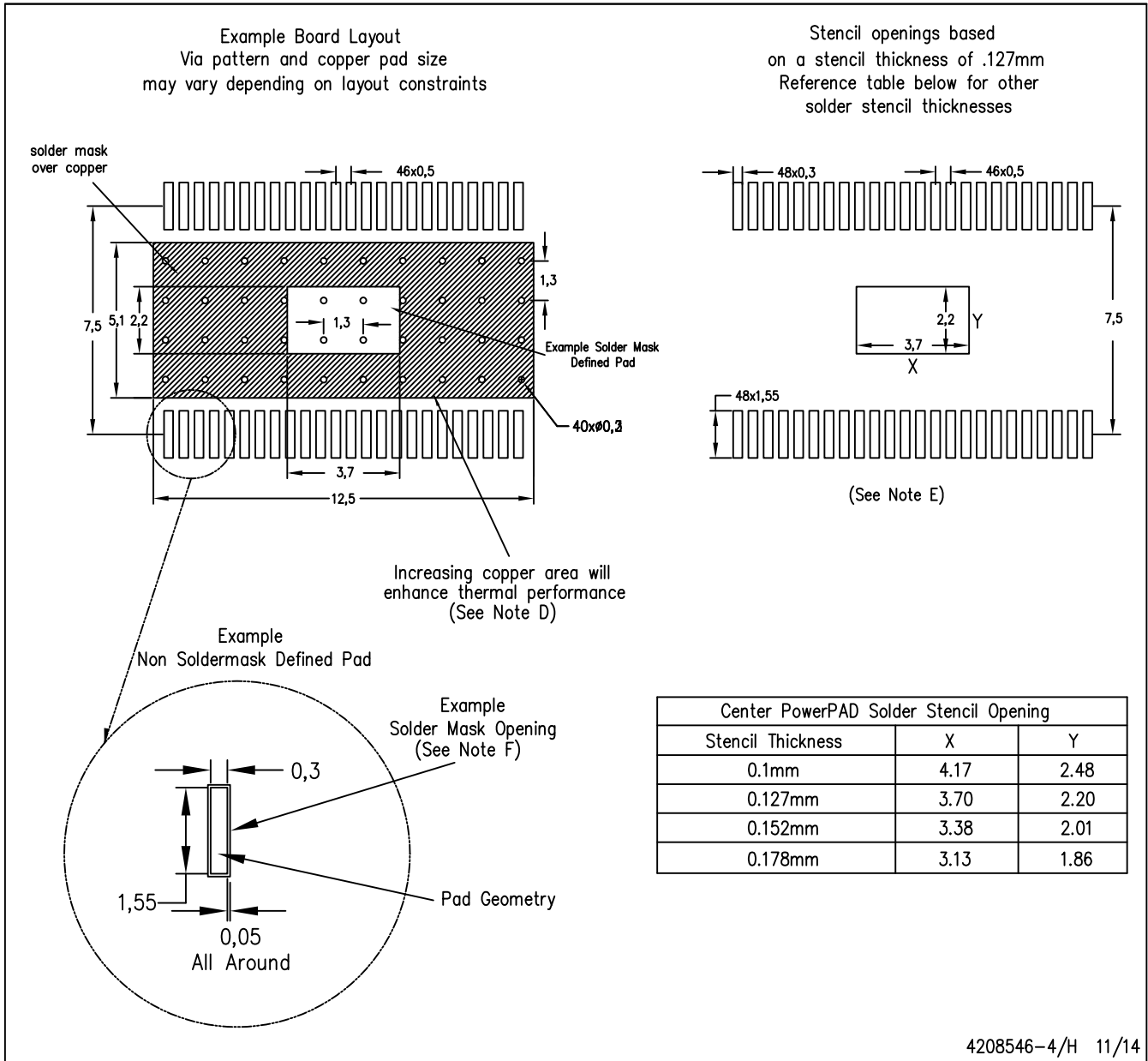

4208546-4/H 11/14

- NOTES:
- A. All linear dimensions are in millimeters.
 - B. This drawing is subject to change without notice.
 - C. Customers should place a note on the circuit board fabrication drawing not to alter the center solder mask defined pad.
 - D. This package is designed to be soldered to a thermal pad on the board. Refer to Technical Brief, PowerPAD Thermally Enhanced Package, Texas Instruments Literature No. SLMA002, SLMA004, and also the Product Data Sheets for specific thermal information, via requirements, and recommended board layout. These documents are available at www.ti.com <<http://www.ti.com>>. Publication IPC-7351 is recommended for alternate designs.
 - E. Laser cutting apertures with trapezoidal walls and also rounding corners will offer better paste release. Customers should contact their board assembly site for stencil design recommendations. Example stencil design based on a 50% volumetric metal load solder paste. Refer to IPC-7525 for other stencil recommendations.
 - F. Customers should contact their board fabrication site for solder mask tolerances between and around signal pads.

IMPORTANT NOTICE

Texas Instruments Incorporated (TI) reserves the right to make corrections, enhancements, improvements and other changes to its semiconductor products and services per JESD46, latest issue, and to discontinue any product or service per JESD48, latest issue. Buyers should obtain the latest relevant information before placing orders and should verify that such information is current and complete.

TI's published terms of sale for semiconductor products (<http://www.ti.com/sc/docs/stdterms.htm>) apply to the sale of packaged integrated circuit products that TI has qualified and released to market. Additional terms may apply to the use or sale of other types of TI products and services.

Reproduction of significant portions of TI information in TI data sheets is permissible only if reproduction is without alteration and is accompanied by all associated warranties, conditions, limitations, and notices. TI is not responsible or liable for such reproduced documentation. Information of third parties may be subject to additional restrictions. Resale of TI products or services with statements different from or beyond the parameters stated by TI for that product or service voids all express and any implied warranties for the associated TI product or service and is an unfair and deceptive business practice. TI is not responsible or liable for any such statements.

Buyers and others who are developing systems that incorporate TI products (collectively, "Designers") understand and agree that Designers remain responsible for using their independent analysis, evaluation and judgment in designing their applications and that Designers have full and exclusive responsibility to assure the safety of Designers' applications and compliance of their applications (and of all TI products used in or for Designers' applications) with all applicable regulations, laws and other applicable requirements. Designer represents that, with respect to their applications, Designer has all the necessary expertise to create and implement safeguards that (1) anticipate dangerous consequences of failures, (2) monitor failures and their consequences, and (3) lessen the likelihood of failures that might cause harm and take appropriate actions. Designer agrees that prior to using or distributing any applications that include TI products, Designer will thoroughly test such applications and the functionality of such TI products as used in such applications.

TI's provision of technical, application or other design advice, quality characterization, reliability data or other services or information, including, but not limited to, reference designs and materials relating to evaluation modules, (collectively, "TI Resources") are intended to assist designers who are developing applications that incorporate TI products; by downloading, accessing or using TI Resources in any way, Designer (individually or, if Designer is acting on behalf of a company, Designer's company) agrees to use any particular TI Resource solely for this purpose and subject to the terms of this Notice.

TI's provision of TI Resources does not expand or otherwise alter TI's applicable published warranties or warranty disclaimers for TI products, and no additional obligations or liabilities arise from TI providing such TI Resources. TI reserves the right to make corrections, enhancements, improvements and other changes to its TI Resources. TI has not conducted any testing other than that specifically described in the published documentation for a particular TI Resource.

Designer is authorized to use, copy and modify any individual TI Resource only in connection with the development of applications that include the TI product(s) identified in such TI Resource. NO OTHER LICENSE, EXPRESS OR IMPLIED, BY ESTOPPEL OR OTHERWISE TO ANY OTHER TI INTELLECTUAL PROPERTY RIGHT, AND NO LICENSE TO ANY TECHNOLOGY OR INTELLECTUAL PROPERTY RIGHT OF TI OR ANY THIRD PARTY IS GRANTED HEREIN, including but not limited to any patent right, copyright, mask work right, or other intellectual property right relating to any combination, machine, or process in which TI products or services are used. Information regarding or referencing third-party products or services does not constitute a license to use such products or services, or a warranty or endorsement thereof. Use of TI Resources may require a license from a third party under the patents or other intellectual property of the third party, or a license from TI under the patents or other intellectual property of TI.

TI RESOURCES ARE PROVIDED "AS IS" AND WITH ALL FAULTS. TI DISCLAIMS ALL OTHER WARRANTIES OR REPRESENTATIONS, EXPRESS OR IMPLIED, REGARDING RESOURCES OR USE THEREOF, INCLUDING BUT NOT LIMITED TO ACCURACY OR COMPLETENESS, TITLE, ANY EPIDEMIC FAILURE WARRANTY AND ANY IMPLIED WARRANTIES OF MERCHANTABILITY, FITNESS FOR A PARTICULAR PURPOSE, AND NON-INFRINGEMENT OF ANY THIRD PARTY INTELLECTUAL PROPERTY RIGHTS. TI SHALL NOT BE LIABLE FOR AND SHALL NOT DEFEND OR INDEMNIFY DESIGNER AGAINST ANY CLAIM, INCLUDING BUT NOT LIMITED TO ANY INFRINGEMENT CLAIM THAT RELATES TO OR IS BASED ON ANY COMBINATION OF PRODUCTS EVEN IF DESCRIBED IN TI RESOURCES OR OTHERWISE. IN NO EVENT SHALL TI BE LIABLE FOR ANY ACTUAL, DIRECT, SPECIAL, COLLATERAL, INDIRECT, PUNITIVE, INCIDENTAL, CONSEQUENTIAL OR EXEMPLARY DAMAGES IN CONNECTION WITH OR ARISING OUT OF TI RESOURCES OR USE THEREOF, AND REGARDLESS OF WHETHER TI HAS BEEN ADVISED OF THE POSSIBILITY OF SUCH DAMAGES.

Unless TI has explicitly designated an individual product as meeting the requirements of a particular industry standard (e.g., ISO/TS 16949 and ISO 26262), TI is not responsible for any failure to meet such industry standard requirements.

Where TI specifically promotes products as facilitating functional safety or as compliant with industry functional safety standards, such products are intended to help enable customers to design and create their own applications that meet applicable functional safety standards and requirements. Using products in an application does not by itself establish any safety features in the application. Designers must ensure compliance with safety-related requirements and standards applicable to their applications. Designer may not use any TI products in life-critical medical equipment unless authorized officers of the parties have executed a special contract specifically governing such use. Life-critical medical equipment is medical equipment where failure of such equipment would cause serious bodily injury or death (e.g., life support, pacemakers, defibrillators, heart pumps, neurostimulators, and implantables). Such equipment includes, without limitation, all medical devices identified by the U.S. Food and Drug Administration as Class III devices and equivalent classifications outside the U.S.

TI may expressly designate certain products as completing a particular qualification (e.g., Q100, Military Grade, or Enhanced Product). Designers agree that it has the necessary expertise to select the product with the appropriate qualification designation for their applications and that proper product selection is at Designers' own risk. Designers are solely responsible for compliance with all legal and regulatory requirements in connection with such selection.

Designer will fully indemnify TI and its representatives against any damages, costs, losses, and/or liabilities arising out of Designer's non-compliance with the terms and provisions of this Notice.