

## Triple-Supply Power Management IC for Powering FPGAs and DSPs

Check for Samples: [TPS75003-EP](#)

### FEATURES

- Two 95% Efficient, 3-A Buck Controllers and One 300-mA LDO
- Tested and Endorsed by Xilinx for Powering the Spartan™-3, Spartan-3E, and Spartan-3L FPGAs
- Adjustable (1.2 V to 6.5 V for Bucks, 1 V to 6.5 V for LDO) Output Voltages on All Channels
- Input Voltage Range: 2.2 V to 6.5 V
- Independent Soft-Start for Each Supply
- Independent Enable for Each Supply for Flexible Sequencing
- LDO Stable with 2.2- $\mu$ F Ceramic Output Capacitor
- Small, Low-Profile 4,5 mm x 3,5 mm x 0,9 mm QFN Package

### SUPPORTS DEFENSE, AEROSPACE, AND MEDICAL APPLICATIONS

- Controlled Baseline
- One Assembly/Test Site
- One Fabrication Site
- Available in Military (–55°C/125°C) Temperature Range<sup>(1)</sup>
- Extended Product Life Cycle
- Extended Product-Change Notification
- Product Traceability

(1) Additional temperature ranges available - contact factory

### APPLICATIONS

- FPGA/DSP/ASIC Supplies
- Set-Top Boxes
- DSL Modems
- Plasma TV Display Panels

### DESCRIPTION

The TPS75003 is a complete power management solution for FPGA, DSP and other multi-supply applications. The device has been tested with and meets all of the Xilinx Spartan-3, Spartan-3E, and Spartan-3L start-up profile requirements, including monotonic voltage ramp and minimum voltage rail rise time. Independent Enables for each output allow sequencing to minimize demand on the power supply at start-up. Soft-start on each supply limits inrush current during start-up. Two integrated buck controllers allow efficient, cost-effective voltage conversion for both low and high current supplies such as core and I/O. A 300-mA LDO is integrated to provide an auxiliary rail such as  $V_{CCAUX}$  on the Xilinx Spartan-3 FPGA. All three supply voltages are offered in user-programmable options for maximum flexibility.

The TPS75003 is fully specified from –55°C to +125°C and is offered in a QFN package, yielding a highly compact total solution size with high power dissipation capability.



Please be aware that an important notice concerning availability, standard warranty, and use in critical applications of Texas Instruments semiconductor products and disclaimers thereto appears at the end of this data sheet.

Spartan is a trademark of Xilinx, Inc.



These devices have limited built-in ESD protection. The leads should be shorted together or the device placed in conductive foam during storage or handling to prevent electrostatic damage to the MOS gates.

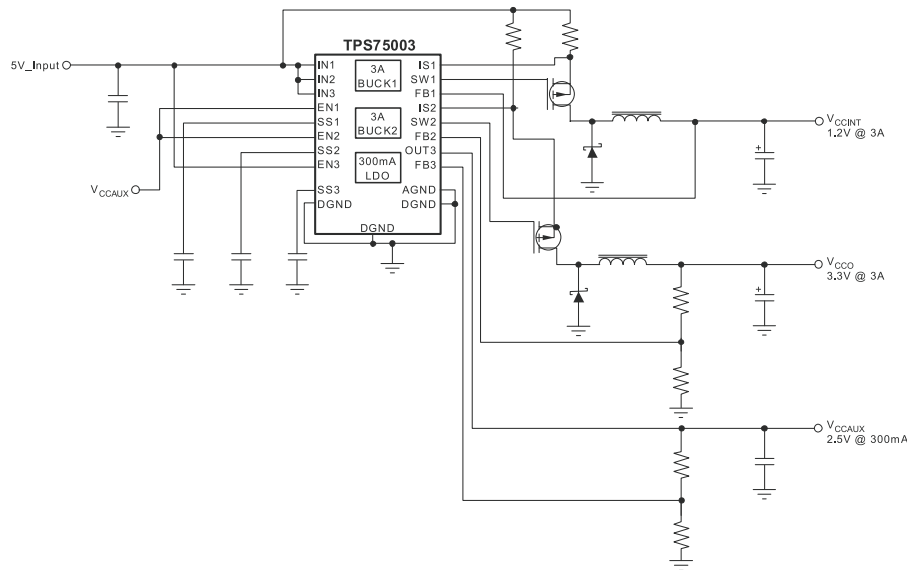

**ORDERING INFORMATION<sup>(1)</sup>**

PRODUCT	V <sub>OUT</sub>
TPS75003MRHLREP	Buck1: Adjustable Buck2: Adjustable LDO: Adjustable

(1) For the most current specifications and package information, see the Package Option Addendum located at the end of this document or see the Texas Instruments website at [www.ti.com](http://www.ti.com).

**ABSOLUTE MAXIMUM RATINGS**

over operating free-air temperature range (unless otherwise noted)<sup>(1)</sup>

	TPS75003	UNIT
V <sub>INX</sub> range (IN1, IN2, IN3)	-0.3 to +7	V
V <sub>ENX</sub> range (EN1, EN2, EN3)	-0.3 to V <sub>INX</sub> + 0.3	V
V <sub>SWX</sub> range (SW1, SW2, SW3)	-0.3 to V <sub>INX</sub> + 0.3	V
V <sub>ISX</sub> range (IS1, IS2, IS3)	-0.3 to V <sub>INX</sub> + 0.3	V
V <sub>OUT3</sub> range	-0.3 to +7	V
V <sub>SSX</sub> range (SS1, SS2, SS3)	-0.3 to V <sub>INX</sub> + 0.3	V
V <sub>FBX</sub> range (FB1, FB2, FB3)	-0.3 to +3.3	V
Peak LDO output current (I <sub>OUT3</sub> )	Internally limited	—
Continuous total power dissipation	See the Thermal Information Table	—
Junction temperature range, T <sub>J</sub>	-55 to +150	°C
Storage temperature range	-65 to +150	°C
ESD rating, HBM	1	kV
ESD rating, CDM	500	V

(1) Stresses beyond those listed under absolute maximum ratings may cause permanent damage to the device. These are stress ratings only, and functional operation of the device at these or any other conditions beyond those indicated under the Electrical Characteristics is not implied. Exposure to absolute maximum rated conditions for extended periods may affect device reliability.

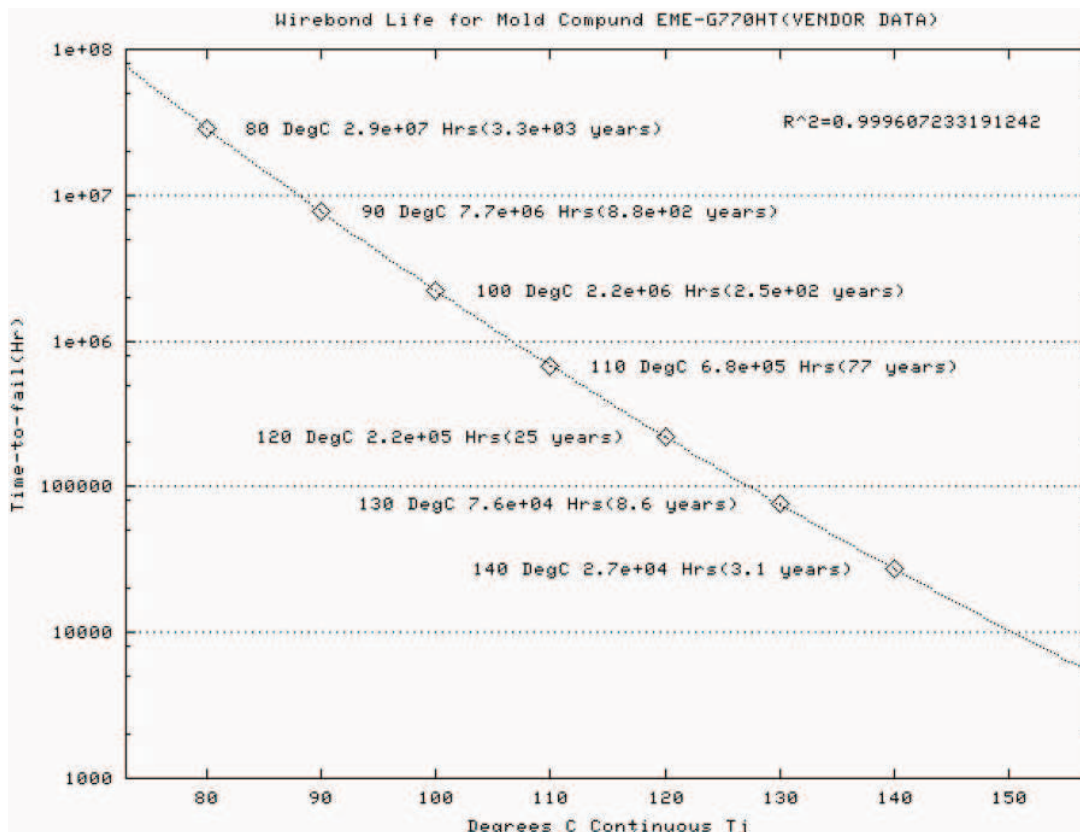

Figure 1. Wirebond Plot

THERMAL INFORMATION

THERMAL METRIC <sup>(1)</sup>		TPS75003-EP	UNITS
		RHL (20 PINS)	
$\theta_{JA}$	Junction-to-ambient thermal resistance	42.6	°C/W
$\theta_{JCTop}$	Junction-to-case (top) thermal resistance	51.8	
$\theta_{JB}$	Junction-to-board thermal resistance	39.5	
$\Psi_{JT}$	Junction-to-top characterization parameter	0.6	
$\Psi_{JB}$	Junction-to-board characterization parameter	14.2	
$\theta_{JCbott}$	Junction-to-case (bottom) thermal resistance	2.8	

(1) For more information about traditional and new thermal metrics, see the *IC Package Thermal Metrics* application report, [SPRA953](#).

## ELECTRICAL CHARACTERISTICS

$V_{EN1} = V_{IN1}$ ,  $V_{EN2} = V_{IN2}$ ,  $V_{EN3} = V_{IN3}$ ,  $V_{IN1} = V_{IN2} = 2.2\text{ V}$ ,  $V_{IN3} = 3\text{ V}$ ,  $V_{OUT3} = 2.5\text{ V}$ ,  $C_{OUT1} = C_{OUT2} = 47\text{ }\mu\text{F}$ ,  $C_{OUT3} = 2.2\text{ }\mu\text{F}$ ,  $T_A = -55^\circ\text{C}$  to  $125^\circ\text{C}$ , unless otherwise noted. Typical values are at  $T_A = 25^\circ\text{C}$ .

PARAMETER		CONDITIONS	MIN	TYP	MAX	UNIT
<b>Supply and Logic</b>						
$V_{INX}$	Input voltage range (IN1, IN2, IN3) <sup>(1)</sup>		2.2		6.5	V
$I_Q$	Quiescent current, $I_Q = I_{DGND} + I_{AGND}$	$I_{OUT1} = I_{OUT2} = I_{OUT3} = 0\text{ mA}$		75	150	$\mu\text{A}$
$I_{SHDN}$	Shutdown supply current	$V_{EN1} = V_{EN2} = V_{EN3} = 0\text{ V}$		0.05	3	$\mu\text{A}$
$V_{IH1,2}$	Enable high, enabled (EN1, EN2)	$T_A = 25^\circ\text{C}$	1.4			V
		$T_A = \text{Full Range}$	1.45			
$V_{IH3}$	Enable High, enabled (EN3)	$T_A = 25^\circ\text{C}$	1.14			V
		$T_A = \text{Full Range}$	1.2			
$V_{ILX}$	Enable low, shutdown (EN1, EN2, EN3)		0		0.3	V
$I_{ENX}$	Enable pin current (EN1, EN2, EN3)			0.01	0.5	$\mu\text{A}$
<b>Buck Controllers 1 and 2</b>						
$V_{OUT1,2}$	Adjustable output voltage Range <sup>(2)</sup>		$V_{FBX}$		$V_{INX}$	V
$V_{FB1,2}$	Feedback voltage (FB1, FB2)			1.22		V
	Feedback voltage accuracy <sup>(1)</sup> (FB1, FB2)			$\pm 2\%$		
$I_{FB1,2}$	Current into FB1, FB2 pins			0.01	0.5	$\mu\text{A}$
$V_{IS1,2}$	Reference voltage for current sense	$T_A = 25^\circ\text{C}$	80	100	120	mV
		$T_A = \text{Full Range}$	75		125	
$I_{IS1,2}$	Current into IS1, IS2 pins			0.01	0.5	$\mu\text{A}$
$\Delta V_{OUT\%}/\Delta V_{IN}$	Line regulation <sup>(1)</sup>	Measured with the circuit in <a href="#">Figure 2</a> , $V_{OUT} + 0.5\text{ V} \leq V_{IN} \leq 6.5\text{ V}$		0.1		% / V
$\Delta V_{OUT\%}/\Delta I_{OUT}$	Load regulation	Measured with the circuit in <a href="#">Figure 2</a> , $30\text{ mA} \leq I_{OUT} \leq 2\text{ A}$		0.6		% / A
$\eta_{1,2}$	Efficiency <sup>(3)</sup>	Measured with the circuit in <a href="#">Figure 2</a> , $I_{OUT} = 1\text{ A}$		94%		
$t_{STR1,2}$	Startup time <sup>(3)</sup>	Measured with the circuit in <a href="#">Figure 2</a> , $R_L = 6\text{ }\Omega$ , $C_{OUT} = 100\text{ }\mu\text{F}$ , $C_{SS} = 2.2\text{ nF}$		5		ms
$R_{DS,ON1,2}$	Gate driver P-Channel and N-Channel MOSFET on-resistance	$V_{IN1,2} > 2.5\text{ V}$		4		$\Omega$
		$V_{IN1,2} = 2.2\text{ V}$		6		
$I_{SW1,2}$	Gate Driver P-Channel and N-Channel MOSFET drive current			100		mA
$t_{ON}$	Minimum on time		1.36	1.55	1.84	$\mu\text{s}$
$t_{OFF}$	Minimum off time		0.44	0.65	0.86	$\mu\text{s}$

(1) To be in regulation, minimum  $V_{IN1}$  (or  $V_{IN2}$ ) must be greater than  $V_{OUT1,NOM}$  (or  $V_{OUT2,NOM}$ ) by an amount determined by external components. Minimum  $V_{IN3} = V_{OUT3} + V_{DO}$  or  $2.2\text{ V}$ , whichever is greater.

(2) Maximum  $V_{OUT}$  is dependent on external components and will be less than  $V_{IN}$ . Parameter is not production tested.

(3) Depends on external components.

**ELECTRICAL CHARACTERISTICS (continued)**

$V_{EN1} = V_{IN1}$ ,  $V_{EN2} = V_{IN2}$ ,  $V_{EN3} = V_{IN3}$ ,  $V_{IN1} = V_{IN2} = 2.2\text{ V}$ ,  $V_{IN3} = 3\text{ V}$ ,  $V_{OUT3} = 2.5\text{ V}$ ,  $C_{OUT1} = C_{OUT2} = 47\text{ }\mu\text{F}$ ,  $C_{OUT3} = 2.2\text{ }\mu\text{F}$ ,  
 $T_A = -55^\circ\text{C}$  to  $125^\circ\text{C}$ , unless otherwise noted. Typical values are at  $T_A = 25^\circ\text{C}$ .

PARAMETER		CONDITIONS	MIN	TYP	MAX	UNIT
<b>LDO</b>						
$V_{OUT3}$	Output voltage range <sup>(4)</sup>		1		$6.5 - V_{DO}$	V
$V_{FB3}$	Feedback pin voltage			0.507		V
	Feedback pin voltage accuracy <sup>(5)</sup>	$2.95\text{ V} \leq V_{IN3} \leq 6.5\text{ V}$ $1\text{ mA} \leq I_{OUT3} \leq 300\text{ mA}$		$\pm 4\%$		
$\Delta V_{OUT\%}/\Delta V_{IN}$	Line regulation <sup>(5)</sup>	$V_{OUT3} + 0.5\text{ V} \leq V_{IN3} \leq 6.5\text{ V}$		0.075		% / V
$\Delta V_{OUT\%}/\Delta I_{OUT}$	Load regulation	$10\text{ mA} \leq I_{OUT3} \leq 300\text{ mA}$		0.01		% / mA
$V_{DO}$	Dropout voltage ( $V_{IN} = V_{OUT(NOM)} - 0.1$ ) <sup>(6)</sup>	$I_{OUT3} = 300\text{ mA}$		250	350	mV
$I_{CL3}$	Current limit	$V_{OUT} = 0.9 \times V_{OUT(NOM)}$	375	600	1000	mA
$I_{FB3}$	Current into FB3 pin			0.03	0.1	$\mu\text{A}$
$V_n$	Output noise	BW = 100 Hz - 100 kHz, $I_{OUT3} = 300\text{ mA}$		400		$\mu\text{V}_{RMS}$
$t_{SD}$	Thermal shutdown temperature for LDO	Shutdown, temperature increasing		175		°C
		Reset, temperature decreasing		160		
UVLO	Undervoltage lockout threshold	$V_{IN}$ rising		1.8		V
	Undervoltage lockout hysteresis	$V_{IN}$ falling		100		mV

(4) Maximum  $V_{OUT}$  is dependent on external components and will be less than  $V_{IN}$ . Parameter is not production tested.

(5) To be in regulation, minimum  $V_{IN1}$  (or  $V_{IN2}$ ) must be greater than  $V_{OUT1,NOM}$  (or  $V_{OUT2,NOM}$ ) by an amount determined by external components. Minimum  $V_{IN3} = V_{OUT3} + V_{DO}$  or 2.2 V, whichever is greater.

(6)  $V_{DO}$  does not apply when  $V_{OUT} + V_{DO} < 2.2\text{ V}$ .

**DEVICE INFORMATION**

**Functional Block Diagram**

**TPS75003**

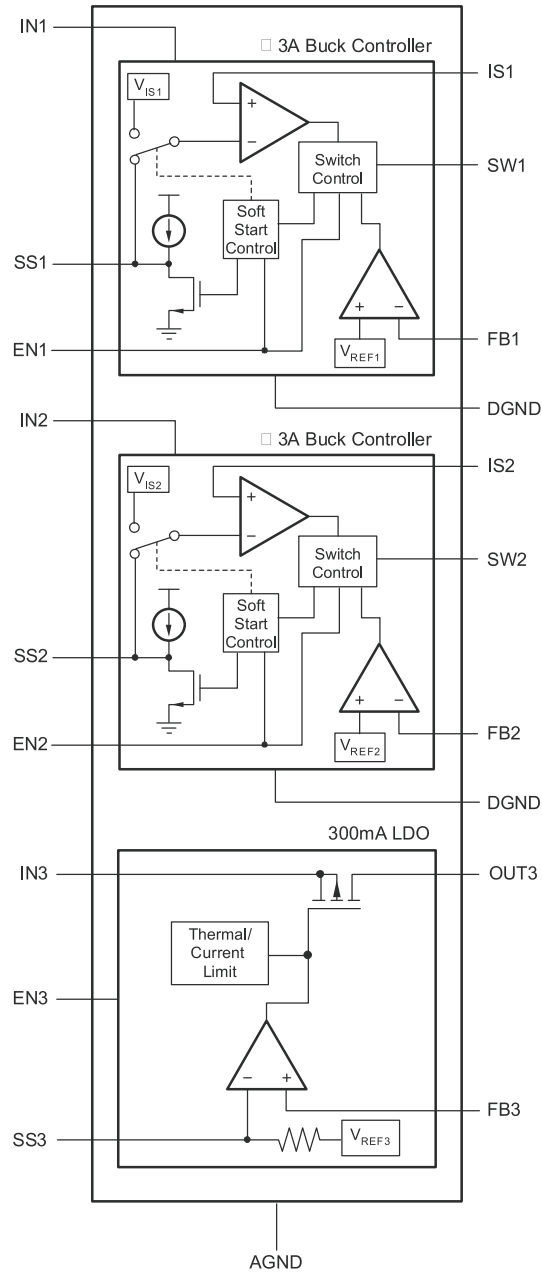

**RHL PACKAGE  
4.5mm x 3.5mm QFN  
(TOP VIEW)**

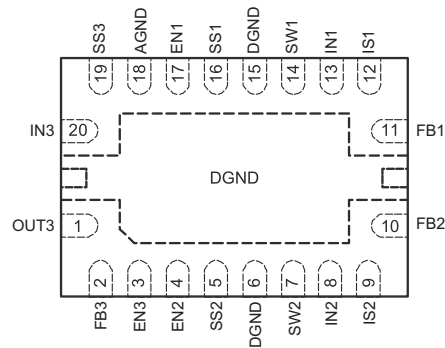

**PIN FUNCTIONS**

PIN		DESCRIPTION
NAME	RHL	
DGND	6, 15, PAD	Ground connection for BUCK1 and BUCK2 converters. Pins 6 and 15 should be connected to the back side exposed pad by a short metal trace as shown in the <i>PCB Layout</i> section of this data sheet.
AGND	18	Ground connection for LDO
IN1	13	Input supply to BUCK1
IN2	8	Input supply to BUCK2
IN3	20	Input supply to LDO
EN1	17	Driving the enable pin (ENx) high turns on BUCK1 regulator. Driving this pin low puts it into shutdown mode, reducing operating current. The enable pin does not trigger on fast negative going transients.
EN2	4	Same as EN1 but for BUCK2 controller
EN3	3	Same as EN1 but for LDO
SS1	16	Connecting a capacitor between this pin and ground increases start-up time of the BUCK1 regulator by slowing the ramp-up of current limit. This high-impedance pin is noise-sensitive; careful layout is important. See the <i>Typical Characteristics, Applications, and PCB Layout</i> sections for details.
SS2	5	Same as SS1 but for BUCK2 regulator.
SS3	19	Connecting a capacitor from this pin to ground slows the start-up time of the LDO reference, thereby slowing output voltage ramp-up. See the <i>Applications</i> section for details.
IS1	12	Current sense input for BUCK1 regulator. The voltage difference between this pin and IN1 is compared to an internal reference to set current limit. For a robust output start-up ramp, careful layout and bypassing are required. See the <i>Applications</i> section for details.
IS2	9	Same as IS1, but compared to IN2 and used for BUCK2 controller
SW1	14	Gate drive pin for external BUCK1 P-channel MOSFET
SW2	7	Same as SW1, but for BUCK2 controller
FB1	11	Feedback pin. Used to set the output voltage of BUCK1 regulator
FB2	10	Same as FB1, but for BUCK2 controller
FB3	2	Same as FB1, but for LDO
OUT3	1	Regulated LDO output. A small ceramic capacitor ( $\geq 2.2 \mu\text{F}$ ) is needed from this pin to ground to ensure stability.

Typical Application Circuit for Powering the Xilinx Spartan-3 FPGA

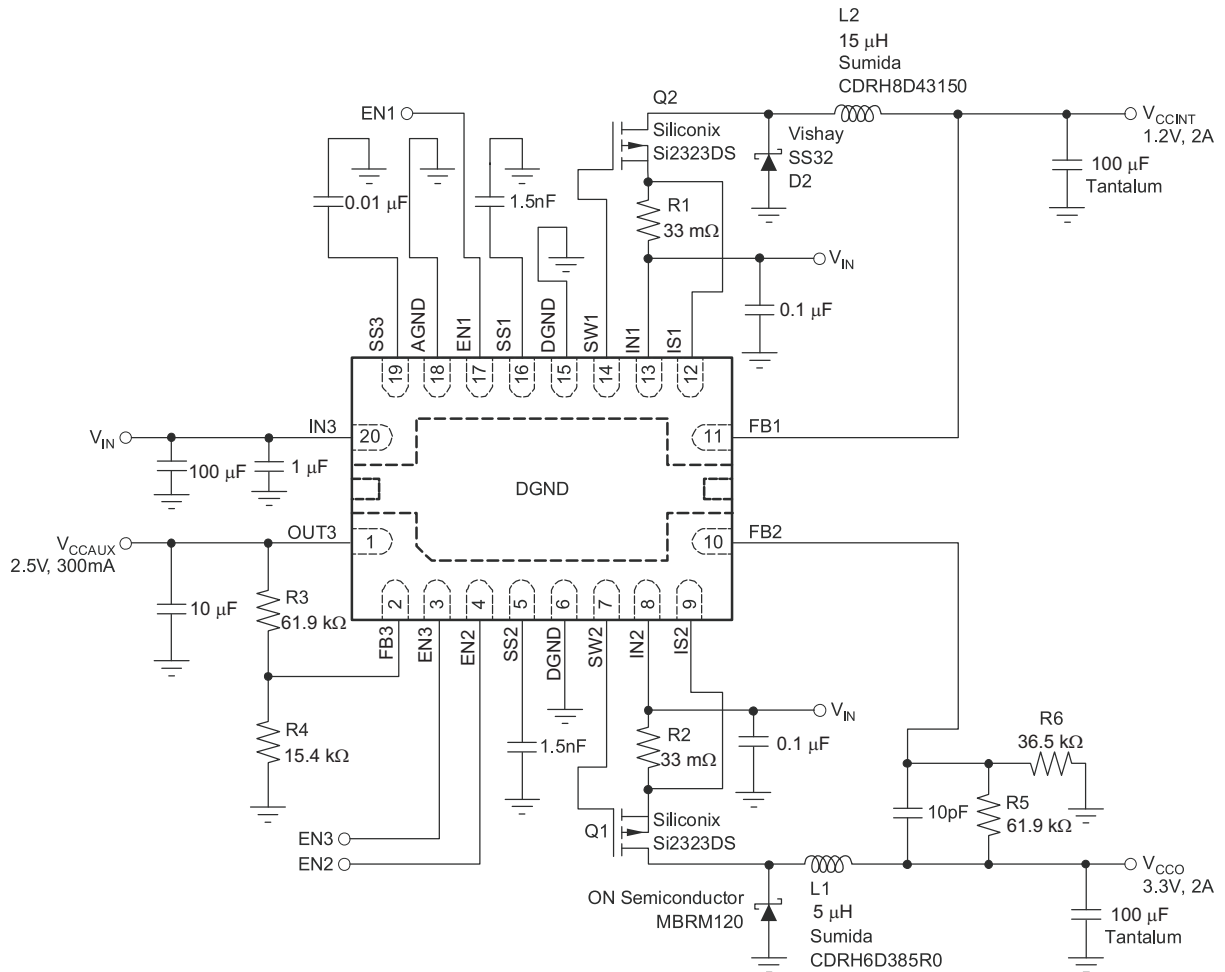

Figure 2.

TYPICAL CHARACTERISTICS

Measured using circuit in Figure 2

Buck Converter

BUCK LOAD REGULATION

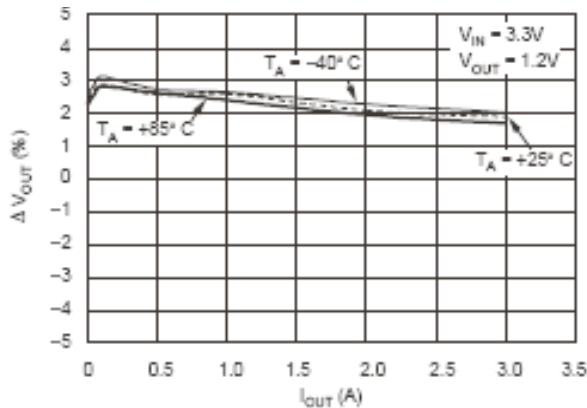

Figure 3.

BUCK LOAD REGULATION

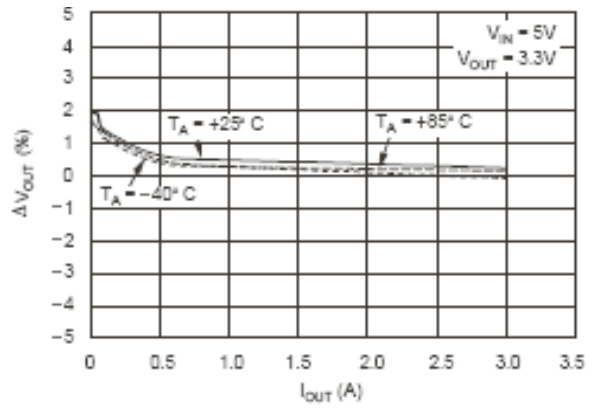

Figure 4.



TYPICAL CHARACTERISTICS (continued)

Measured using circuit in Figure 2

BUCK LINE REGULATION

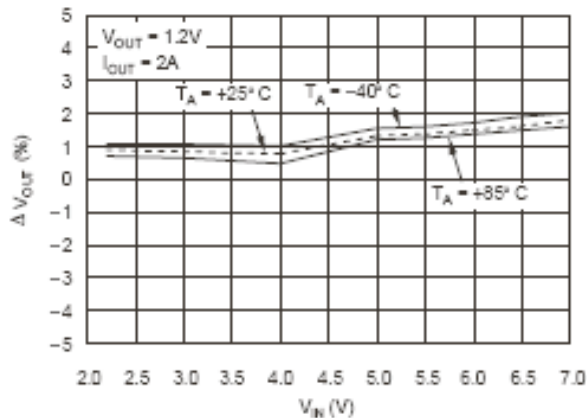

Figure 5.

BUCK LINE REGULATION

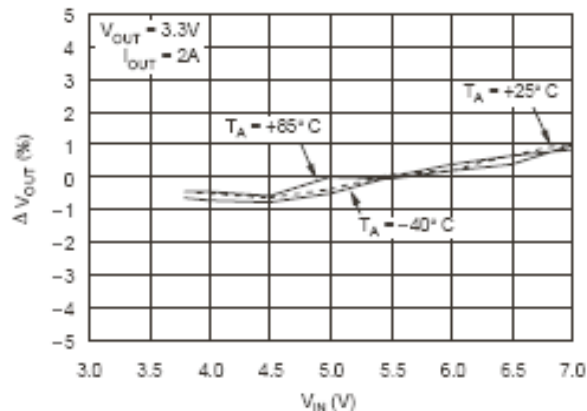

Figure 6.

BUCK SWITCHING FREQUENCY vs Iout, Ta

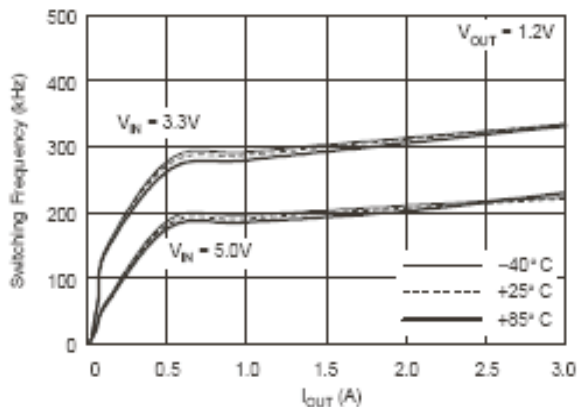

Figure 7.

BUCK SWITCHING FREQUENCY vs Iout

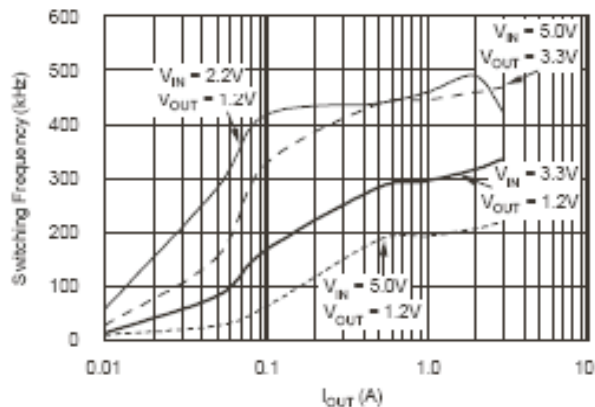

Figure 8.

BUCK OUTPUT VOLTAGE RIPPLE

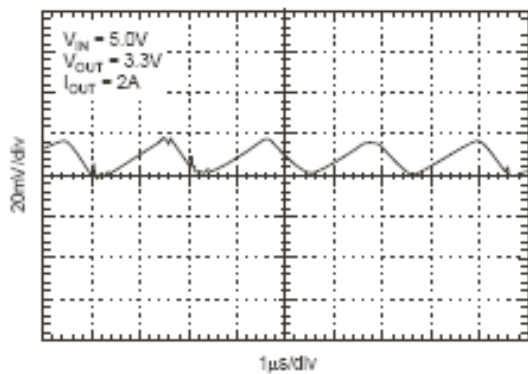

Figure 9.

EFFICIENCY vs Iout

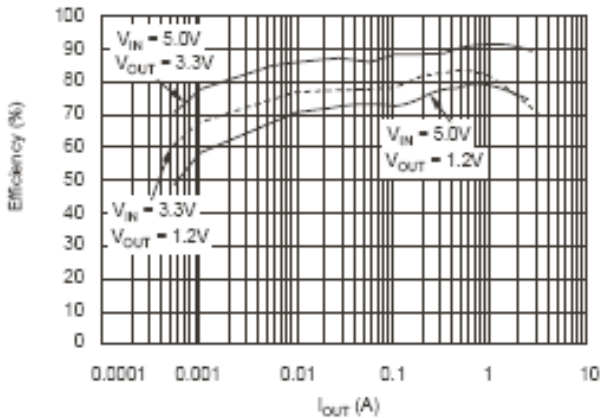

Figure 10.

TYPICAL CHARACTERISTICS (continued)

Measured using circuit in Figure 2

BUCK START-UP  
vs  
 $V_{IN}$  and  $I_{OUT}$

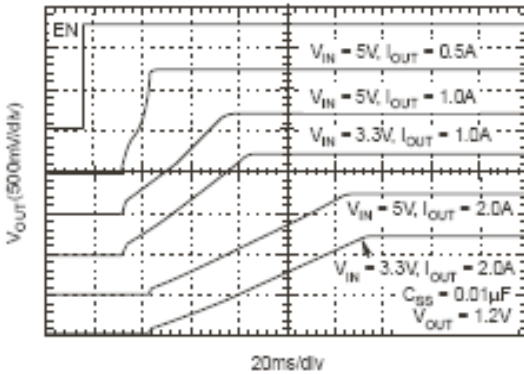

Figure 11.

BUCK START-UP  
vs  
 $V_{IN}$  and  $C_{OUT}$

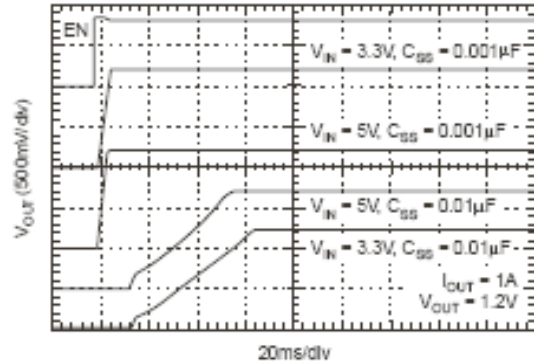

Figure 12.

BUCK START-UP  
vs  
 $V_{IN}$  and  $C_{SS}$

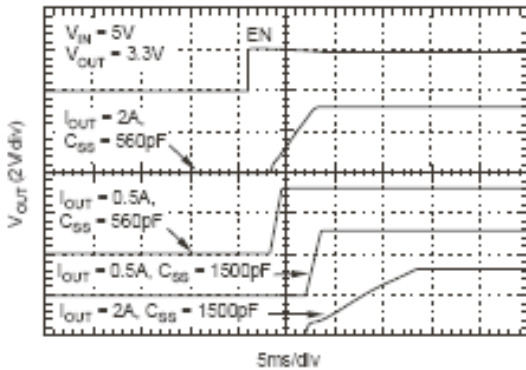

Figure 13.

BUCK START-UP  
vs  
 $I_{OUT}$  and  $C_{SS}$

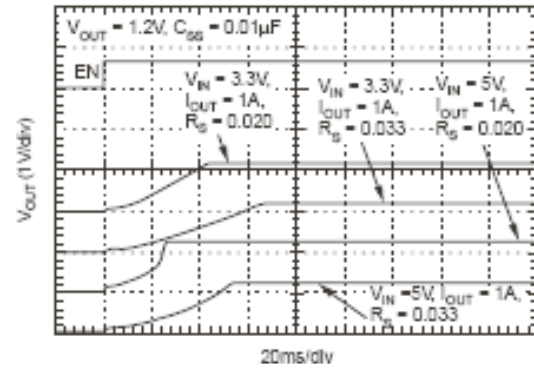

Figure 14.

LDO Converter

LDO LOAD REGULATION

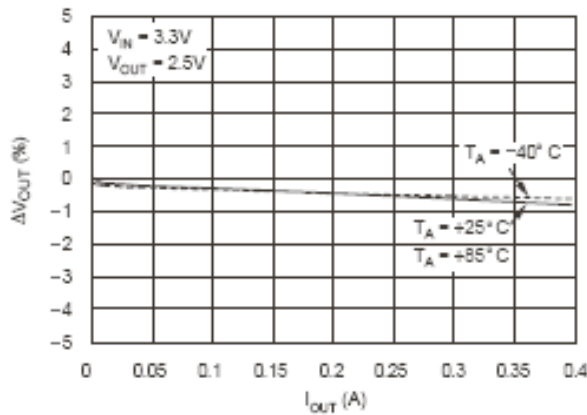

Figure 15.

LDO LINE REGULATION

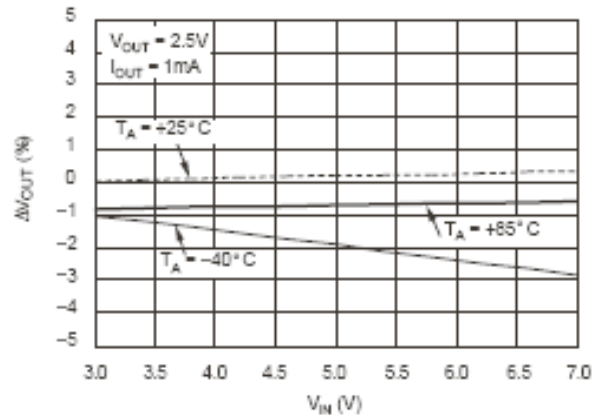
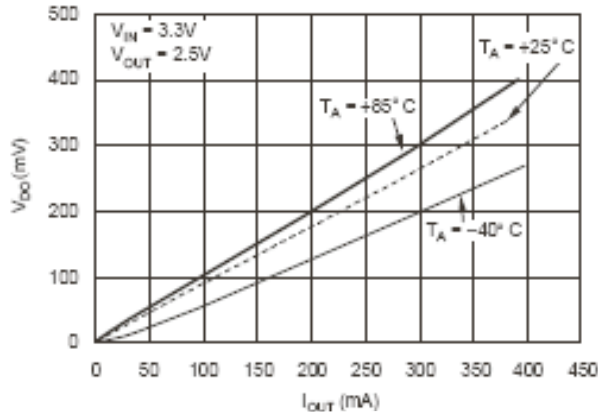

Figure 16.

**TYPICAL CHARACTERISTICS (continued)**

Measured using circuit in [Figure 2](#)

**LDO DROPOUT vs  $I_{OUT}$**



**Figure 17.**

**LDO DROPOUT vs  $T_A$**

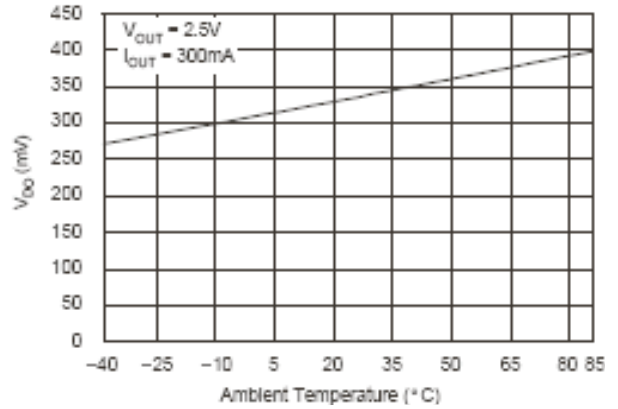

**Figure 18.**

**$R_{DS,ON}$  PMOS vs  $V_{IN}$**

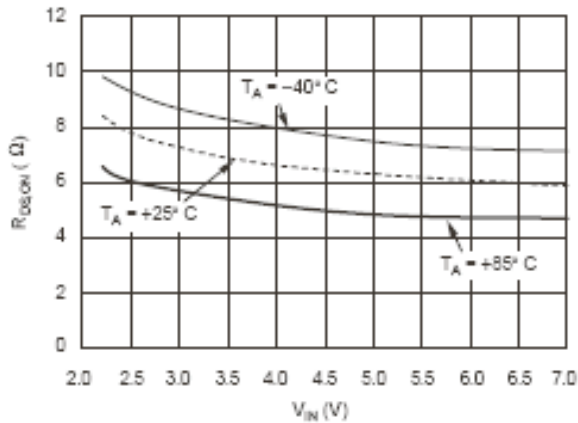

**Figure 19.**

**$R_{DS,ON}$  NMOS vs  $V_{IN}$**

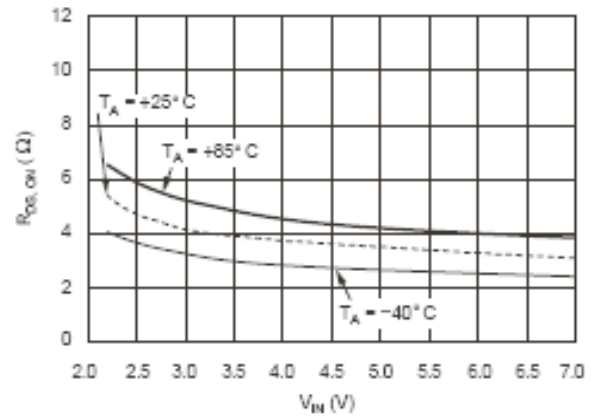

**Figure 20.**

**LDO  $V_{OUT}$  vs  $T_A$**

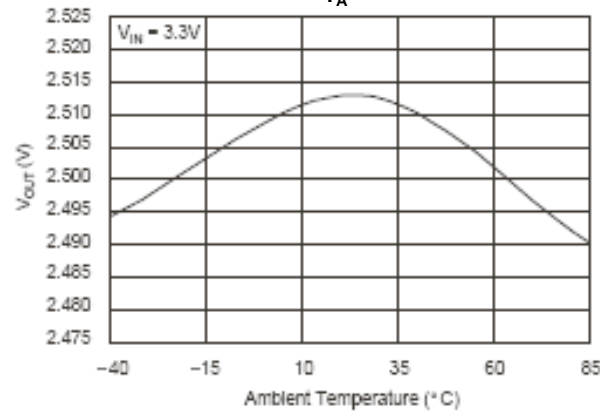

**Figure 21.**

## APPLICATION INFORMATION

The TPS75003 is an integrated power management IC designed specifically to power DSPs and FPGAs such as the Xilinx Spartan-3, Spartan-3E and Spartan-3L. Two non-synchronous buck controllers can be configured to supply up to 3 A for both CORE and I/O rails. A low dropout linear regulator powers auxiliary rails up to 300 mA. All channels have independent enable and soft-start, allowing control of inrush current and output voltage ramp time as required by the application.

Figure 2 shows a typical application circuit for powering the Xilinx Spartan-3 FPGA. Table 1 through Table 4 show component values that have been tested for use with 2-A and 3-A load currents. Other similar external components can be substituted as desired; however, in all cases the circuits that are used should be tested for compliance to application requirements.

**Table 1. Inductors Tested with the TPS75003**

PART NUMBER	MANUFACTURER	INDUCTANCE	DC RESISTANCE	SATURATION CURRENT
SLF7032T-100M1R4	TDK	10 $\mu$ H $\pm$ 20%	53 m $\Omega$ $\pm$ 20%	1.4 A
SLF6025-150MR88	TDK	15 $\mu$ H $\pm$ 20%	85 m $\Omega$ $\pm$ 20%	0.88 A
CDRH6D28-5R0	Sumida	5 $\mu$ H	23 m $\Omega$	2.4 A
CDRH6D38-5R0	Sumida	5 $\mu$ H	18 m $\Omega$	2.9 A
CDRH103R-100	Sumida	10 $\mu$ H	45 m $\Omega$	2.4 A
CDRH4D28-100	Sumida	10 $\mu$ H	96 m $\Omega$	1 A
CDRH8D43-150	Sumida	15 $\mu$ H	42 m $\Omega$	2.9 A
CDRH5D18-6R2	Sumida	6.2 $\mu$ H	71 m $\Omega$	1.4 A
DO3316P-472	Coilcraft	4.7 $\mu$ H	18 m $\Omega$	5.4 A
DT3316P-153	Coilcraft	15 $\mu$ H	60 m $\Omega$	1.8 A
DT3316P-223	Coilcraft	22 $\mu$ H	84 m $\Omega$	1.5 A
744052006	Würth	6.2 $\mu$ H	80 m $\Omega$	1.45 A
74451115	Würth	15 $\mu$ H	90 m $\Omega$	0.8 A

**Table 2. PMOS Transistors Tested with the TPS75003**

PART NUMBER	MANUFACTURER	R <sub>DS,ON</sub> (TYP)	V <sub>DS</sub>	I <sub>D</sub>	PACKAGE
Si5447DC	Vishay Siliconix	0.11 $\Omega$ at VGS = -2.5 V	-20 V	-3.5 A at +25°C	1206
Si5475DC	Vishay Siliconix	0.041 $\Omega$ at VGS = -2.5 V	-12 V	-6.6 A at +25°C	1206
Si2323DS	Vishay Siliconix	0.052 $\Omega$ at VGS = -2.5 V	-20 V	-4.1 A at +25°C	SOT23
Si2301ADS	Vishay Siliconix	0.19 $\Omega$ at VGS = -2.5 V	-20 V	-1.4 A at +25°C	SOT23
Si2323DS	Vishay Siliconix	0.41 $\Omega$ at VGS = -2.5 V	-20 V	-4.1 A at +25°C	SOT23
FDG326P	Fairchild	0.17 $\Omega$ at VGS = -2.5 V	-20 V	-1.5 A	SC70

**Table 3. Diodes Tested with the TPS75003**

PART NUMBER	MANUFACTURER	V <sub>R</sub>	I <sub>F</sub>	PACKAGE
MBRM120LT3	ON Semiconductor	20 V	1 A	DO216AA
MBR0530T1	ON Semiconductor	30 V	1.5 A	SOD123
ZHCS2000TA	Zetex	40 V	2 A	SOT23-6
B320	Diodes Inc.	20 V	3 A	SMA
SS32	Fairchild	20 V	3 A	DO214AB

**Table 4. Capacitors Tested with the TPS75003**

PART NUMBER	MANUFACTURER	CAPACITANCE	ESR	VOLTAGE RATING
6TPB47M (PosCap)	Sanyo	47 $\mu$ F	0.1 $\Omega$	6.3 V
T491D476M010AS	Kemet	47 $\mu$ F	0.8 $\Omega$	10 V
B45197A	Epco	47 $\mu$ F	0.175 $\Omega$	16 V
B45294-R1107-M40	Epco	100 $\mu$ F	0.045 $\Omega$	6.3 V
594D476X0016C2	Vishay	47 $\mu$ F	0.11 $\Omega$	16 V
594D127X96R3C2	Vishay	120 $\mu$ F	0.085 $\Omega$	6.3 V
TPSC107K006R0150	AVX	100 $\mu$ F	0.15 $\Omega$	6.3 V
6TPS100MC	Sanyo	100 $\mu$ F	0.45 $\Omega$	6.3 V

## OPERATION (BUCK CONTROLLERS)

Channels 1 and 2 contain two identical non-synchronous buck controllers that use minimum on-time/minimum off-time hysteric control. (See [Figure 2.](#)) For clarity, BUCK1 is used throughout the discussion of device operation. When  $V_{OUT1}$  is below its target, an external PMOS (Q1) is turned on for at least the minimum on-time, increasing current through the inductor (L1) until  $V_{OUT1}$  reaches its target value or the current limit (set by R1) is reached. Once either of these conditions is met, the PMOS is switched off for at least the minimum off-time of the device. After the minimum off-time has passed, the output voltage is monitored and the switch is turned on again when necessary.

When output current is low, the buck controllers operate in discontinuous mode. In this mode, each switching cycle begins at zero inductor current, rises to a maximum value, then falls back to zero current. When current reaches zero on the falling edge, ringing occurs at the resonant frequency of the inductor and stray switch node capacitance. This is normal operation; it does not affect circuit performance, and can be minimized if desired by using an RC snubber and/or a resistor in series with the gate of the PMOS, as shown in [Figure 22.](#)

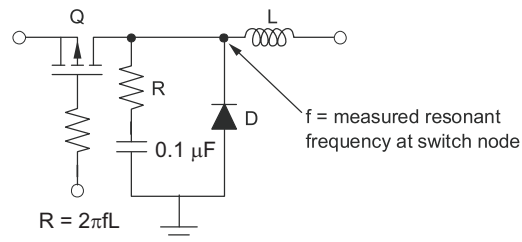
**Figure 22. RC Snubber and Series Gate Resistor Used to Minimize Ringing**

At higher output currents, the TPS75003 operates in continuous mode. In continuous mode, there is no ringing at the switch node and  $V_{OUT}$  is equal to  $V_{IN}$  times the duty cycle of the switching waveform.

When  $V_{IN}$  approaches or falls below  $V_{OUT}$ , the buck controllers operate in 100% duty cycle mode, fully turning on the external PMOS to allow regulation at lower dropout than would otherwise be possible.

### Enable (Buck Controllers)

The enable pins (EN1 and EN2) for the buck controllers are active high. When the enable pin is driven low and input voltage is present at IN1 or IN2, an on-chip FET is turned on to discharge the soft-start pin SS1 or SS2, respectively. If the soft-start feature is being used, enable should be driven high at least 10 $\mu$ s after  $V_{IN}$  is applied to ensure this discharge cycle occurs.

### UVLO (Buck Controllers)

An under-voltage lockout circuit is present to prevent turning on the external PMOS (Q1 or Q2) until a reliable operating voltage is reached on the appropriate regulator (IN1 or IN2). This prevents the buck controllers from mis-operation at low input voltages.

### Current Limit (Buck Controllers)

An external resistor (R1 or R2) is used to set the current limit for the external PMOS transistor (Q1 or Q2). These resistors are connected between IN1 and IS1 (or IN2 and IS2) to provide a reference voltage across these pins that is proportional to the current flowing through the PMOS transistor. This reference voltage is compared to an internal reference to determine if an over-current condition exists. When current limit is exceeded, the external PMOS is turned off for the minimum off-time. Current limit detection is disabled for 10 ns any time the PMOS is turned on to avoid triggering on switching noise. In 100% duty cycle mode, current limit is always enabled. Current limit is calculated using the  $V_{IS1}$  or  $V_{IS2}$  specification in the *Electrical Characteristics* section, shown in [Equation 1](#).

$$I_{LIMIT} = \frac{V_{IS1,2}}{R_{1,2}} \quad (1)$$

The current limit resistor must be appropriately rated for the dissipated power determined by its RMS current calculated by [Equation 2](#).

$$I_{RMS} = I_{OUT} \sqrt{D} = I_{OUT} \sqrt{\frac{V_{OUT}}{V_{IN}}}$$

$$P_{DISS} = (I_{RMS})^2 \times R \quad (2)$$

For low-cost applications the  $I_{S1,2}$  pin can be connected to the drain of the PMOS, using  $R_{DS,ON}$  instead of R1 or R2 to set current limit. Variations in the PMOS  $R_{DS,ON}$  must be taken into account to ensure that current limit will protect external components such as the inductor, the diode, and the switch itself from damage as a result of overcurrent.

### Short-Circuit Protection (Buck Controllers)

In an overload condition, the current rating of the external components (PMOS, diode, and inductor) can be exceeded. To help guard against this, the TPS75003 increases its minimum off-time when the voltage at the feedback pin is lower than the reference voltage. When the output is shorted ( $V_{FB}$  is zero), minimum off-time is increased to approximately 4  $\mu$ s. The increase in off-time is proportional to the difference between the voltage at the feedback pin and the internal reference.

### Soft-Start (Buck Controllers)

The buck controllers each have independent soft-start capability to limit inrush during start-up and to meet timing requirements of the Xilinx Spartan-3 FPGA. Limiting inrush current by using soft-start, or by staggering the turn-on of power rails, also guards against voltage drops at the input source due to its output impedance. See the soft-start circuitry shown in [Figure 23](#) and the soft-start timing diagram shown in [Figure 24](#). BUCK 1 will be discussed in this section; it is identical to BUCK2. Note that pins SS1 and SS2 are high-impedance and cannot be probed using a typical oscilloscope setup. When input voltage is applied at IN1 and EN1 is driven low, any charge on the SS pin is discharged by an on-chip pulldown transistor. When EN1 is driven high, an on-chip current source starts charging the external soft-start capacitor  $C_{SS1}$ . The voltage on the capacitor is compared to the voltage across the current sense resistor R1 to determine if an over-current condition exists. If the voltage drop across the sense resistor goes above the reference voltage, then the external PMOS is shut off for the minimum off-time. This implementation provides a cycle-by-cycle current limit and allows the user to program the soft-start time over a wide range for most applications. For detailed information on choosing  $C_{SS1}$  and  $C_{SS2}$ , see the section, *Selecting the Soft-Start Cap*.

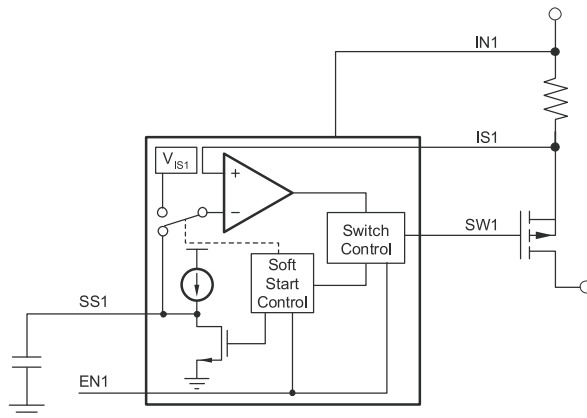

Figure 23. Soft-Start Circuitry

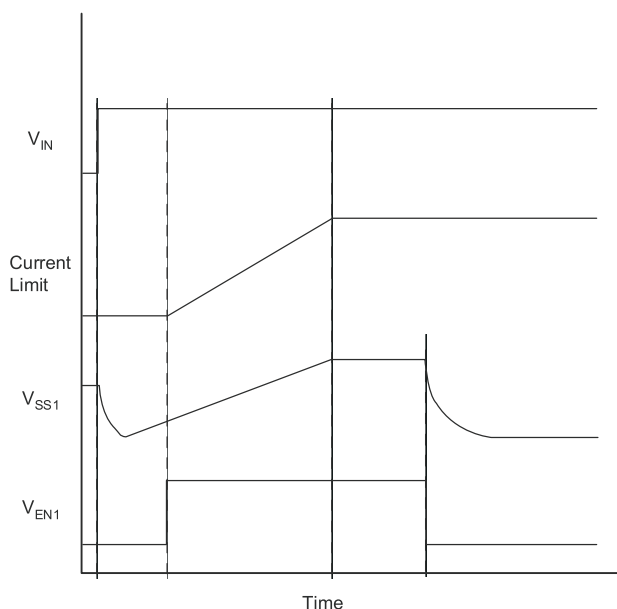

Figure 24. Soft-Start Timing Diagram

### Input Capacitor $C_{IN1}$ , $C_{IN2}$ Selection (Buck Controllers)

It is good analog design practice to place input capacitors near the inputs of the device in order to ensure a low impedance input supply. A capacitance of 10  $\mu\text{F}$  to 22  $\mu\text{F}$  for each buck converter is adequate for most applications, and should be placed within 100 mils (0.001 in) of the IN1 and IN2 pins to minimize the effects of pulsed current switching noise on the soft-start circuitry during the first ~1 V of output voltage ramp. Low ESR capacitors also help to minimize noise on the supply line. The minimum value of capacitance can be estimated using Equation 3.

$$C_{IN, MIN} = \frac{(1/2)L \times (\Delta I_L)^2}{V_{RIPPLE} \times V_{IN}} \approx \frac{(1/2)L \times (0.3 \times I_{OUT})^2}{V_{RIPPLE} \times V_{IN}} \quad (3)$$

Note that the capacitors must be able to handle the RMS current in continuous conduction mode, which can be calculated using Equation 4.

$$I_{C,IN(RMS)} \approx \sqrt{\left(\frac{V_{OUT}}{V_{IN,MIN}}\right)} \quad (4)$$



### Inductor Value Selection (Buck Controllers)

The inductor is chosen based on inductance value and maximum current rating. Larger inductors reduce current ripple (and therefore, output voltage ripple) but are physically larger and more expensive. Inductors with lower DC resistance typically improve efficiency, but also have higher cost and larger physical size. The buck converters work well with inductor values between 4.7  $\mu\text{H}$  and 47  $\mu\text{H}$  in most applications. When selecting an inductor, the current rating should exceed the current limit set by  $R_{\text{IS}}$  or  $R_{\text{DS,ON}}$  (see *Current Limit* section). To determine the minimum inductor size, first determine if the device will operate in minimum on-time or minimum off-time mode. The device will operate in minimum on-time mode if [Equation 5](#) is satisfied.

$$V_{\text{IN}} - V_{\text{OUT}} - I_{\text{OUT}} \times r_{\text{DS(on)}} - R_{\text{L}} \times I_{\text{OUT}} \geq \frac{t_{\text{(OFF,min)}} \times (V_{\text{OUT}} + V_{\text{SCHOTTKY}} + R_{\text{L}} \times I_{\text{OUT}})}{t_{\text{ON,MIN}}} \quad (5)$$

where  $R_{\text{L}}$  = the inductor's DC resistance.

Minimum inductor size needed when operating in minimum on-time mode is given by [Equation 6](#).

$$L_{\text{MIN}} = \frac{(V_{\text{IN}} - V_{\text{OUT}} - I_{\text{OUT}} \times r_{\text{DS(on)}} - R_{\text{L}} \times I_{\text{OUT}}) \times t_{\text{ON,MIN}}}{\Delta I} \quad (6)$$

Minimum inductor size needed when operating in minimum off-time mode is given by [Equation 7](#).

$$L_{\text{MIN}} = \frac{(V_{\text{OUT}} + V_{\text{SCHOTTKY}} + R_{\text{L}} \times I_{\text{OUT}}) \times t_{\text{OFF,MIN}}}{\Delta I} \quad (7)$$

### External PMOS Transistor Selection (Buck Controllers)

The external PMOS transistor is selected based on threshold voltage ( $V_{\text{T}}$ ), on-resistance ( $R_{\text{DS,ON}}$ ), gate capacitance ( $C_{\text{G}}$ ) and voltage rating. The PMOS  $V_{\text{T}}$  magnitude must be much lower than the lowest voltage at IN1 or IN2 that will be used. A  $V_{\text{T}}$  magnitude that is 0.5 V less than the lowest input voltage is normally sufficient. The PMOS gate will see voltages from 0 V to the maximum input voltage, so gate-to-source breakdown should be a few volts higher than the maximum input supply. The drain-to-source of the device will also see this full voltage swing, and should therefore be a few volts higher than the maximum input supply. The RMS current in the PMOS can be estimated by using [Equation 8](#).

$$I_{\text{PMOS(RMS)}} \approx I_{\text{OUT}} \sqrt{D} = I_{\text{OUT}} \sqrt{\frac{V_{\text{OUT}}}{V_{\text{IN}}}} \quad (8)$$

The power dissipated in the PMOS is comprised of both conduction and switching losses. Switching losses are typically insignificant. The conduction losses are a function of the RMS current and the  $R_{\text{DS,ON}}$  of the PMOS, and are calculated by [Equation 9](#).

$$P_{\text{(cond)}} = (I_{\text{OUT}} \sqrt{D})^2 \times r_{\text{DS(on)}} \times (1 + \text{TC} \times [T_{\text{J}} - 25^{\circ}\text{C}]) \approx (I_{\text{OUT}} \sqrt{D}) \times r_{\text{DS(on)}} \quad (9)$$



### Diode Selection (Buck Controllers)

The diode is off when the PMOS is on, and on when the PMOS is off. Since it will be turned on and off at a relatively high frequency, a Schottky diode is recommended for good performance. The peak current rating of the diode should exceed the peak current limit set by the sense resistor  $R_{IS1,2}$ . A diode with low reverse leakage current and low forward voltage at operating current will optimize efficiency. Equation 10 calculates the estimated average power dissipation.

$$I_{(\text{diode})(\text{RMS})} \approx I_{\text{OUT}}(1 - D) = I_{\text{OUT}} \left( 1 - \frac{V_{\text{OUT}}}{V_{\text{IN}}} \right) \quad (10)$$

### Output Capacitor Selection (Buck Controllers)

The output capacitor is selected based on output voltage ripple and transient response requirements. As a result of the nature of the hysteretic control loop, a minimum ESR of a few tens of  $m\Omega$  should be maintained for good operation unless a feed-forward resistor is used. Low ESR bulk tantalum or PosCap capacitors work best in most applications. A 1- $\mu\text{F}$  ceramic capacitor can be used in parallel with this capacitor to filter higher frequency spikes. The output voltage ripple can be estimated by Equation 11.

$$\Delta V_{\text{PP}} = \Delta I \times \left[ \text{ESR} + \left( \frac{1}{8 \times C_{\text{OUT}} \times f} \right) \right] \approx 1.1 \Delta I \times \text{ESR} \quad (11)$$

To calculate the capacitance needed to achieve a given voltage ripple as a result of a load transient from zero output to full current, use Equation 12.

$$C_{\text{OUT}} = \frac{L \times \Delta I_{\text{OUT}}^2}{(V_{\text{IN}} - V_{\text{OUT}}) \times \Delta V} \quad (12)$$

If only ceramic or other very low ESR output capacitor configurations are desired, additional voltage ripple must be passed to the feedback pin. See Application Note, Using Ceramic Output Capacitors with the TPS6420x Buck Controllers (SLVA210), for detailed application information.

### Output Voltage Ripple Effect on $V_{\text{OUT}}$ (Buck Controllers)

Output voltage ripple causes  $V_{\text{OUT}}$  to be higher or lower than the target value by half of the peak-to-peak voltage ripple. For minimum on-time, the ripple adds to the voltage; for minimum off-time, it subtracts from the voltage.

### Soft-Start Capacitor Selection (Buck Controllers)

BUCK1 is discussed in this section; it is identical to BUCK2. Soft-start is implemented on the buck controllers by ramping current limit from 0 to its target value (set by R1) over a user-defined time. This time is set by the external soft-start cap connected to pin SS1. If SS1 is left open, a small on-chip capacitor will provide a current limit ramp time of approximately 250  $\mu\text{s}$ . Figure 25 shows the effects of R1 and SS1 on the current limit start-up ramp.

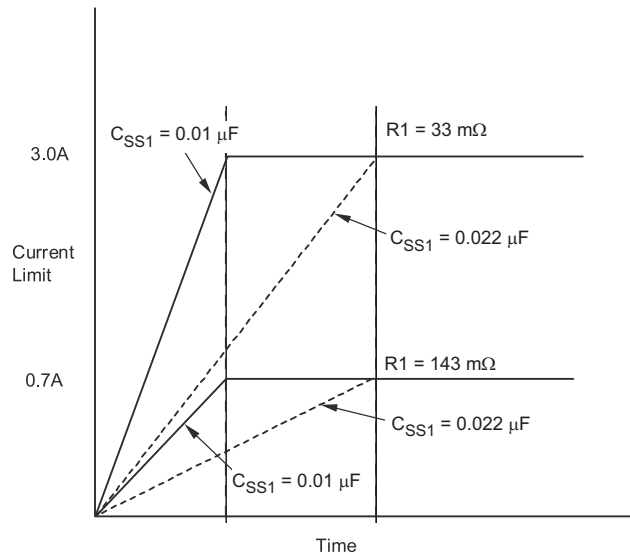

**Figure 25. Effects of  $C_{SS1}$  and  $R_1$  on Current Ramp Limit**

This soft-start current limit ramp can be used to provide inrush current control or output voltage ramp control. While the current limit ramp can be easily understood by looking at [Figure 25](#), the output voltage ramp is a complex function of many variables. The dominant variables in this process are  $V_{OUT1}$ ,  $C_{SS1}$ ,  $I_{OUT1}$ , and  $R_1$ . Less important variables are  $V_{IN1}$  and  $L_1$ .

The best way to set a target start-up time is through bench measurement under target conditions, adjusting  $C_{SS1}$  to get the desired startup profile. To stay above a minimum start-up time, set the nominal start-up time to approximately five times the minimum. To stay below a maximum time, set the nominal start-up time at one-fifth of the maximum. Fastest start-up times occur at maximum  $V_{IN1}$ , with minimum  $V_{OUT1}$ ,  $L_1$ ,  $C_{OUT1}$ ,  $C_{SS1}$ , and  $I_{OUT1}$ . Slowest start-up times occur under opposite conditions.

See [Figure 11](#) to [Figure 14](#) for characterization curves showing how the start-up profile is affected by these critical parameters.

### Output Voltage Setting Selection (Buck Controllers)

Output voltage is set using two resistors as shown for Buck2 in [Figure 2](#). Output voltage is then calculated using [Equation 13](#).

$$V_{OUT} = V_{FB} \left( \frac{R_5}{R_6} + 1 \right) \quad (13)$$

where  $V_{FB} = 1.24V$ .

### LDO OPERATION

The TPS75003 LDO uses a PMOS pass element and is offered in an adjustable version for ease of programming to any output voltage. When used to power  $V_{CC,AUX}$  it is set to 2.5 V; it can optionally be set to other output voltages to power other circuitry. The LDO has integrated soft-start, independent enable, and short-circuit and thermal protection. The LDO can be used to power  $V_{CC,AUX}$  on the Xilinx Spartan-3 FPGA when 3.3-V JTAG signals are used as described in Application Note [SLVA159](#) (available for download from [www.ti.com](http://www.ti.com)).

### Input Capacitor Selection (LDO)

Although an input capacitor is not required, it is good analog design practice to connect a 0.1- $\mu F$  to 10- $\mu F$  low ESR capacitor across the input supply near the regulator. This capacitor counteracts reactive input sources and improves transient response, stability, and ripple rejection. A higher value capacitor may be needed if large, fast rise-time load transients are anticipated, or if the device is located far from its power source.

### Output Capacitor Selection (LDO)

A 2.2  $\mu\text{F}$  or greater capacitor is required near the output of the device to ensure stability. The LDO is stable with any capacitor type, including ceramic. If improved transient response or ripple rejection is required, larger and/or lower ESR output capacitors can be used.

### Soft-Start (LDO)

The LDO uses an external soft-start capacitor,  $C_{SS3}$ , to provide an RC-ramped reference voltage to the control loop. (See the Functional Block Diagram.) This is a voltage-controlled soft-start, as compared to the current-controlled soft-start used by the buck controllers.

### Setting Output Voltage (LDO)

Output voltage is set using two resistors as shown in [Figure 2](#). Output voltage is then calculated using [Equation 14](#).

$$V_{\text{OUT}} = V_{\text{FB}} \left( \frac{R_3}{R_4} + 1 \right) \quad (14)$$

where  $V_{\text{FB}} = 0.507 \text{ V}$ .

### Internal Current Limit (LDO)

The internal current limit of the LDO helps protect the regulator during fault conditions. When an over-current condition is detected, the output voltage will be reduced until the current falls to a level that will not damage the device. For good device reliability, the LDO should not operate at current limit.

### Enable Pin (LDO)

The active high enable pin (EN3) can be used to put the device into shutdown mode. If shutdown and soft-start capability are not required, EN3 can be tied to IN3.

### Dropout Voltage (LDO)

The LDO uses a PMOS transistor to achieve low dropout. When  $(V_{\text{IN}} - V_{\text{OUT}})$  is less than the dropout voltage ( $V_{\text{DO}}$ ), the pass device is in its linear region of operation, and the input-output resistance is the  $R_{\text{DS,ON}}$  of the pass transistor. In this region, the regulator is said to be out of regulation; ripple rejection, line regulation, and load regulation degrade as  $(V_{\text{IN}} - V_{\text{OUT}})$  falls much below 0.5 V.

### Transient Response (LDO)

The LDO does not have an on-chip pulldown circuit for output is over-voltage conditions. This feature permits applications that connect higher voltage sources such as an alternate power supply to the output. This design also results in an output overshoot of several percent if the load current quickly drops to zero. The amplitude of overshoot can be reduced by increasing  $C_{\text{OUT}}$ ; the duration of overshoot can be reduced by adding a load resistor.

### Thermal Protection (LDO)

Thermal protection disables the output when the junction temperature,  $T_{\text{J}}$ , reaches unsafe levels. When the junction cools, the output is again enabled. Depending on power dissipation, thermal resistance, and ambient temperature, the thermal protection circuit may cycle on and off. This cycling limits the dissipation of the regulator, protecting it from damage. For good long term reliability, the device should not be continuously operated at or near thermal shutdown.

### Power Dissipation (LDO)

The TPS75003 comes in a QFN-style package with an exposed lead frame on the package underside. The exposed lead frame is the primary path for removing heat and should be soldered to a PC board that is configured to remove the amount of power dissipated by the LDO, as calculated by [Equation 15](#).

$$P_D = (V_{IN3} - V_{OUT3}) \times I_{OUT3} \tag{15}$$

Power dissipation can be minimized by using the lowest possible input voltage necessary to assure the required output voltage. The two buck converters do not contribute a significant amount of dissipated power. Using heavier copper increases the overall effectiveness of removing heat from the device. The addition of plated through-holes to heat-dissipating layers also improves the heatsink effectiveness.

### PCB Layout Considerations

As with any switching regulators, careful attention must be paid to board layout. A typical application circuit and corresponding recommended printed circuit board (PCB) layout with emphasis on the most sensitive areas are shown in [Figure 26](#) through [Figure 28](#).

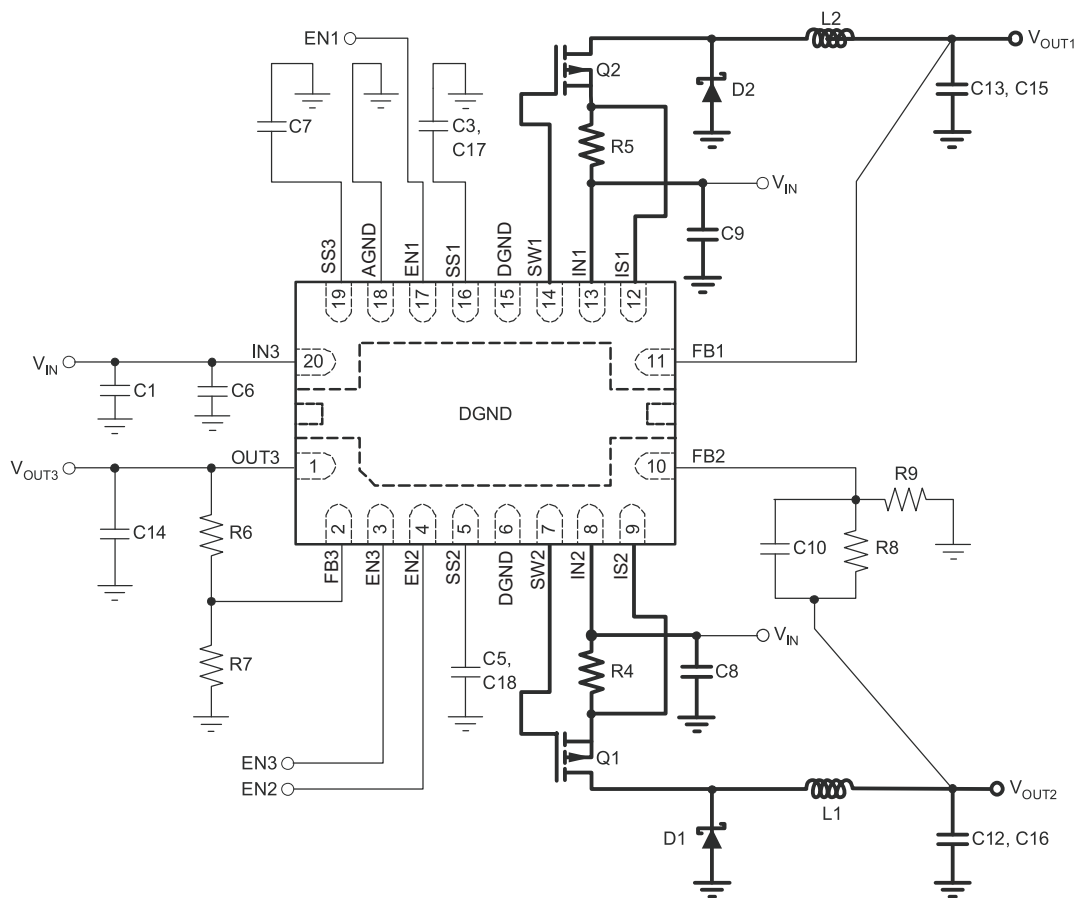

Note: Most sensitive areas are highlighted by bold lines.

**Figure 26. Typical Application Circuit**

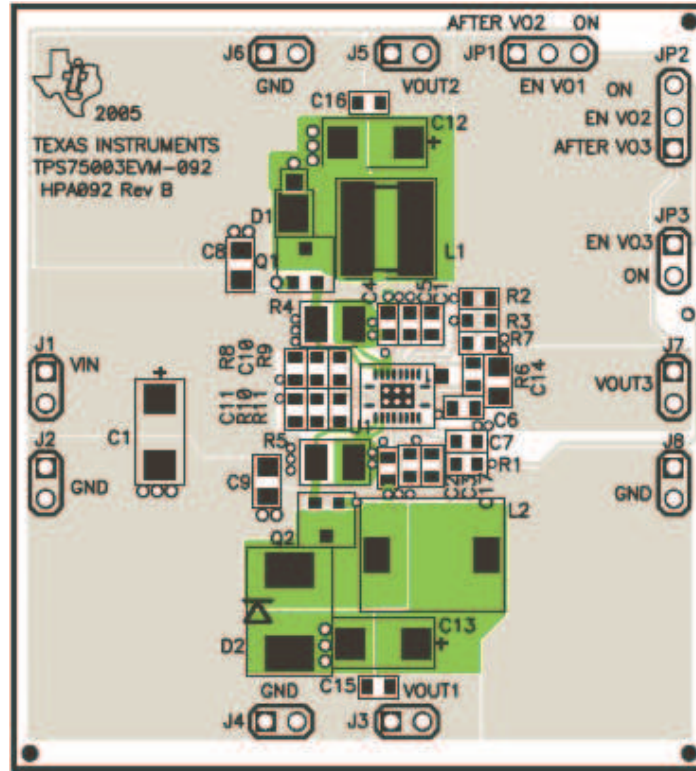

Note: Most sensitive areas are highlighted in green.

Figure 27. Recommended PCB Layout, Component Side, Top View

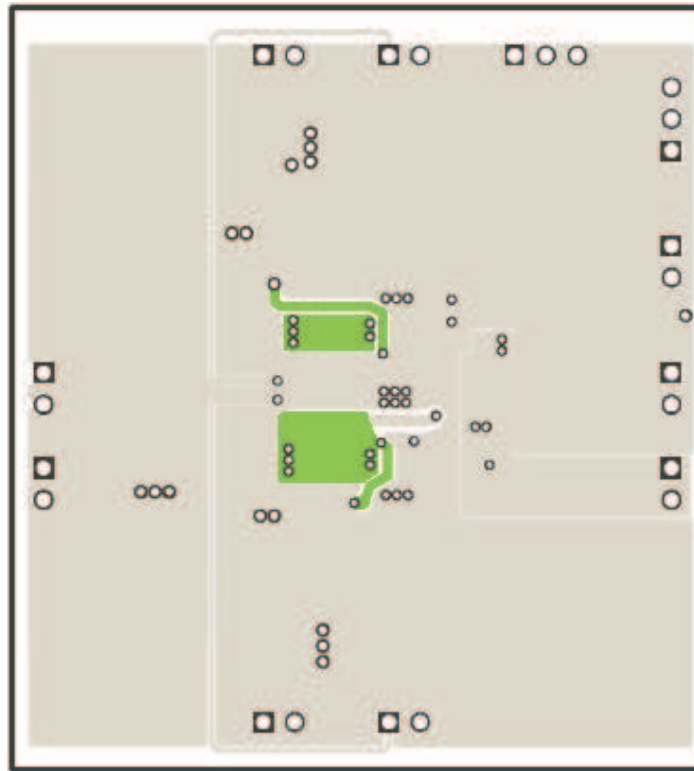

Note: Most sensitive areas are highlighted in green.

**Figure 28. Recommended PCB Layout, Bottom Side, Top View**

---

**REVISION HISTORY**

---

**Changes from Original (December 2006) to Revision A** **Page**

- 
- Replaced the DISSIPATION RATINGS table with the Thermal Information Table ..... **3**
-

**TAPE AND REEL INFORMATION**

**QUADRANT ASSIGNMENTS FOR PIN 1 ORIENTATION IN TAPE**

\*All dimensions are nominal

Device	Package Type	Package Drawing	Pins	SPQ	Reel Diameter (mm)	Reel Width W1 (mm)	A0 (mm)	B0 (mm)	K0 (mm)	P1 (mm)	W (mm)	Pin1 Quadrant
TPS75003MRHLREP	VQFN	RHL	20	3000	330.0	12.4	3.8	4.8	1.6	8.0	12.0	Q1



TAPE AND REEL BOX DIMENSIONS



\*All dimensions are nominal

Device	Package Type	Package Drawing	Pins	SPQ	Length (mm)	Width (mm)	Height (mm)
TPS75003MRHLREP	VQFN	RHL	20	3000	367.0	367.0	35.0

RHL (R-PVQFN-N20)

PLASTIC QUAD FLATPACK NO-LEAD

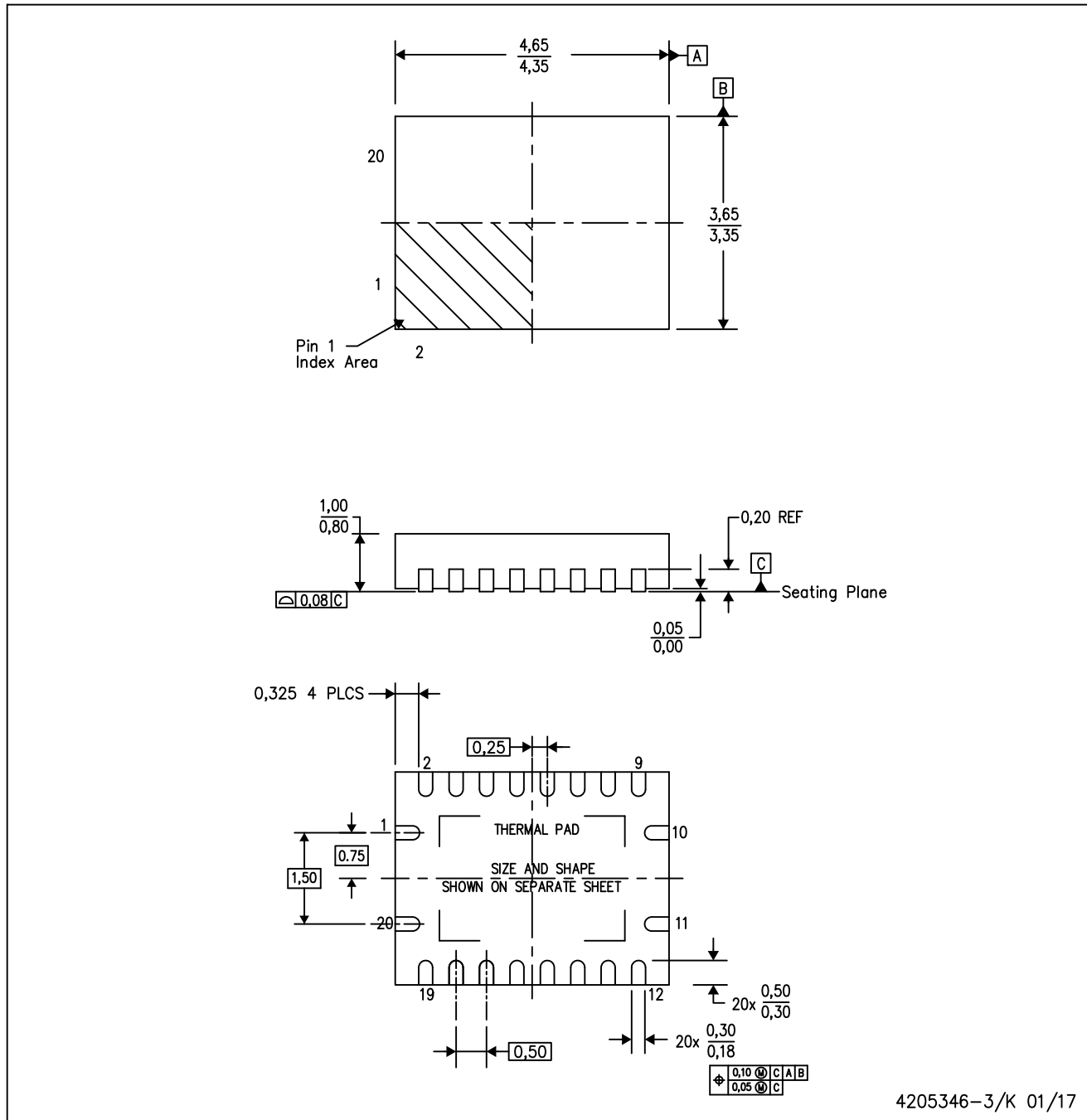

- NOTES:
- All linear dimensions are in millimeters. Dimensioning and tolerancing per ASME Y14.5M-1994.
  - This drawing is subject to change without notice.
  - QFN (Quad Flatpack No-Lead) Package configuration.
  - The package thermal pad must be soldered to the board for thermal and mechanical performance.
  - See the additional figure in the Product Data Sheet for details regarding the exposed thermal pad features and dimensions.

## THERMAL PAD MECHANICAL DATA

RHL (S-PVQFN-N20)

PLASTIC QUAD FLATPACK NO-LEAD

### THERMAL INFORMATION

This package incorporates an exposed thermal pad that is designed to be attached directly to an external heatsink. The thermal pad must be soldered directly to the printed circuit board (PCB). After soldering, the PCB can be used as a heatsink. In addition, through the use of thermal vias, the thermal pad can be attached directly to the appropriate copper plane shown in the electrical schematic for the device, or alternatively, can be attached to a special heatsink structure designed into the PCB. This design optimizes the heat transfer from the integrated circuit (IC).

For information on the Quad Flatpack No-Lead (QFN) package and its advantages, refer to Application Report, QFN/SON PCB Attachment, Texas Instruments Literature No. SLUA271. This document is available at [www.ti.com](http://www.ti.com).

The exposed thermal pad dimensions for this package are shown in the following illustration.

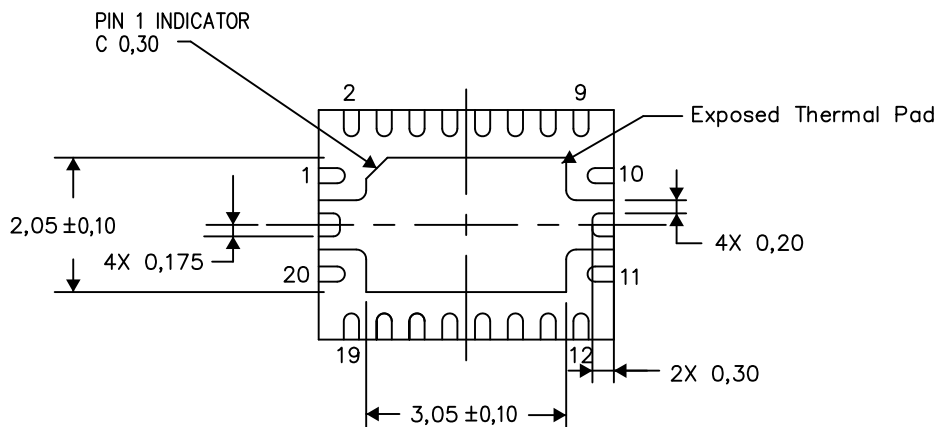

Bottom View

Exposed Thermal Pad Dimensions

4206363-3/N 07/14

NOTE: All linear dimensions are in millimeters

RHL (R-PVQFN-N20)

PLASTIC QUAD FLATPACK NO-LEAD

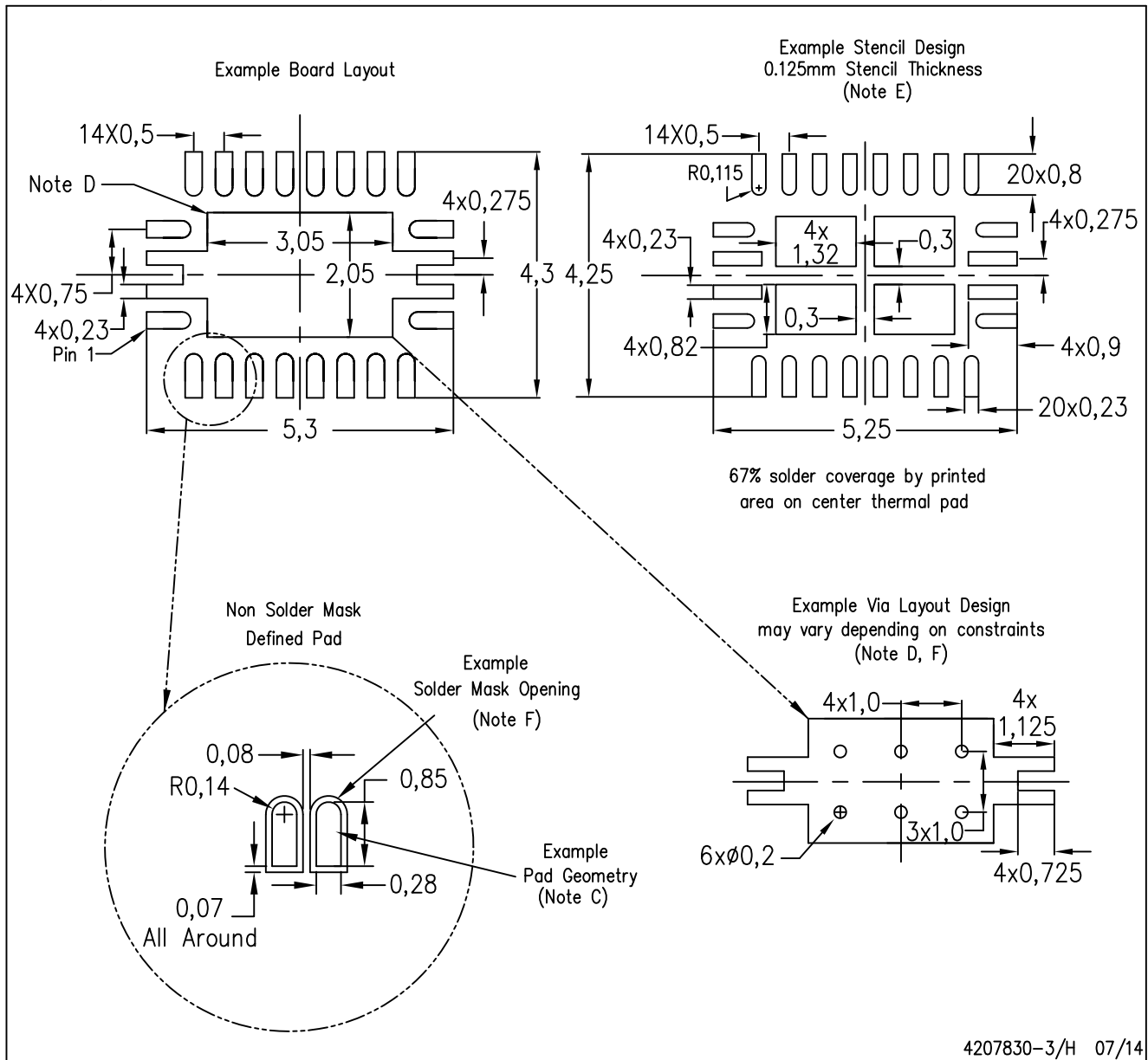

- NOTES:
- All linear dimensions are in millimeters.
  - This drawing is subject to change without notice.
  - Publication IPC-7351 is recommended for alternate designs.
  - This package is designed to be soldered to a thermal pad on the board. Refer to Application Note, Quad Flat-Pack Packages, Texas Instruments Literature No. SLUA271, and also the Product Data Sheets for specific thermal information, via requirements, and recommended board layout. These documents are available at [www.ti.com](http://www.ti.com) <<http://www.ti.com>>.
  - Laser cutting apertures with trapezoidal walls and also rounding corners will offer better paste release. Customers should contact their board assembly site for stencil design recommendations. Refer to IPC 7525 for stencil design considerations.
  - Customers should contact their board fabrication site for minimum solder mask web tolerances between signal pads.

## IMPORTANT NOTICE FOR TI DESIGN INFORMATION AND RESOURCES

Texas Instruments Incorporated ("TI") technical, application or other design advice, services or information, including, but not limited to, reference designs and materials relating to evaluation modules, (collectively, "TI Resources") are intended to assist designers who are developing applications that incorporate TI products; by downloading, accessing or using any particular TI Resource in any way, you (individually or, if you are acting on behalf of a company, your company) agree to use it solely for this purpose and subject to the terms of this Notice.

TI's provision of TI Resources does not expand or otherwise alter TI's applicable published warranties or warranty disclaimers for TI products, and no additional obligations or liabilities arise from TI providing such TI Resources. TI reserves the right to make corrections, enhancements, improvements and other changes to its TI Resources.

You understand and agree that you remain responsible for using your independent analysis, evaluation and judgment in designing your applications and that you have full and exclusive responsibility to assure the safety of your applications and compliance of your applications (and of all TI products used in or for your applications) with all applicable regulations, laws and other applicable requirements. You represent that, with respect to your applications, you have all the necessary expertise to create and implement safeguards that (1) anticipate dangerous consequences of failures, (2) monitor failures and their consequences, and (3) lessen the likelihood of failures that might cause harm and take appropriate actions. You agree that prior to using or distributing any applications that include TI products, you will thoroughly test such applications and the functionality of such TI products as used in such applications. TI has not conducted any testing other than that specifically described in the published documentation for a particular TI Resource.

You are authorized to use, copy and modify any individual TI Resource only in connection with the development of applications that include the TI product(s) identified in such TI Resource. NO OTHER LICENSE, EXPRESS OR IMPLIED, BY ESTOPPEL OR OTHERWISE TO ANY OTHER TI INTELLECTUAL PROPERTY RIGHT, AND NO LICENSE TO ANY TECHNOLOGY OR INTELLECTUAL PROPERTY RIGHT OF TI OR ANY THIRD PARTY IS GRANTED HEREIN, including but not limited to any patent right, copyright, mask work right, or other intellectual property right relating to any combination, machine, or process in which TI products or services are used. Information regarding or referencing third-party products or services does not constitute a license to use such products or services, or a warranty or endorsement thereof. Use of TI Resources may require a license from a third party under the patents or other intellectual property of the third party, or a license from TI under the patents or other intellectual property of TI.

TI RESOURCES ARE PROVIDED "AS IS" AND WITH ALL FAULTS. TI DISCLAIMS ALL OTHER WARRANTIES OR REPRESENTATIONS, EXPRESS OR IMPLIED, REGARDING TI RESOURCES OR USE THEREOF, INCLUDING BUT NOT LIMITED TO ACCURACY OR COMPLETENESS, TITLE, ANY EPIDEMIC FAILURE WARRANTY AND ANY IMPLIED WARRANTIES OF MERCHANTABILITY, FITNESS FOR A PARTICULAR PURPOSE, AND NON-INFRINGEMENT OF ANY THIRD PARTY INTELLECTUAL PROPERTY RIGHTS.

TI SHALL NOT BE LIABLE FOR AND SHALL NOT DEFEND OR INDEMNIFY YOU AGAINST ANY CLAIM, INCLUDING BUT NOT LIMITED TO ANY INFRINGEMENT CLAIM THAT RELATES TO OR IS BASED ON ANY COMBINATION OF PRODUCTS EVEN IF DESCRIBED IN TI RESOURCES OR OTHERWISE. IN NO EVENT SHALL TI BE LIABLE FOR ANY ACTUAL, DIRECT, SPECIAL, COLLATERAL, INDIRECT, PUNITIVE, INCIDENTAL, CONSEQUENTIAL OR EXEMPLARY DAMAGES IN CONNECTION WITH OR ARISING OUT OF TI RESOURCES OR USE THEREOF, AND REGARDLESS OF WHETHER TI HAS BEEN ADVISED OF THE POSSIBILITY OF SUCH DAMAGES.

You agree to fully indemnify TI and its representatives against any damages, costs, losses, and/or liabilities arising out of your non-compliance with the terms and provisions of this Notice.

This Notice applies to TI Resources. Additional terms apply to the use and purchase of certain types of materials, TI products and services. These include; without limitation, TI's standard terms for semiconductor products (<http://www.ti.com/sc/docs/stdterms.htm>), [evaluation modules](#), and [samples](http://www.ti.com/sc/docs/sampterm.htm) (<http://www.ti.com/sc/docs/sampterm.htm>).

Mailing Address: Texas Instruments, Post Office Box 655303, Dallas, Texas 75265  
Copyright © 2017, Texas Instruments Incorporated