

## TS5A23166 0.9-Ω Dual-SPST Analog Switch 5-V and 3.3-V 2-Channel Analog Switch

### 1 Features

- Isolation in Powered-Down Mode,  $V_+ = 0$
- Low ON-State Resistance (0.9 Ω)
- Control Inputs are 5.5-V Tolerant
- Low Charge Injection
- Excellent ON-State Resistance Matching
- Low Total Harmonic Distortion (THD)
- 1.65-V to 5.5-V Single-Supply Operation
- Latch-Up Performance Exceeds 100 mA Per JESD 78, Class II
- ESD Performance Tested Per JESD 22
  - 2000-V Human-Body Model (A114-B, Class II)
  - 1000-V Charged-Device Model (C101)

### 2 Applications

- Cell Phones
- Portable Instrumentation
- Audio and Video Signal Routing
- Low-Voltage Data-Acquisition Systems
- Communication Circuits
- Modems
- Hard Drives
- Computer Peripherals
- Wireless Terminals and Peripherals

### 3 Description

The TS5A23166 device is a dual single-pole single-throw (SPST) analog switch that is designed to operate from 1.65 V to 5.5 V. The TS5A23166 device offers a low ON-state resistance and an excellent channel-to-channel ON-state resistance matching. The TS5A23166 device has excellent total harmonic distortion (THD) performance and consumes very low power. These features make this device suitable for portable audio applications.

#### Device Information<sup>(1)</sup>

PART NUMBER	PACKAGE	BODY SIZE (NOM)
TS5A23166	VSSOP (8)	2.30 mm × 2.00 mm
	DSBGA (8)	1.91 mm × 0.91 mm

(1) For all available packages, see the orderable addendum at the end of the data sheet.

#### Simplified Schematic

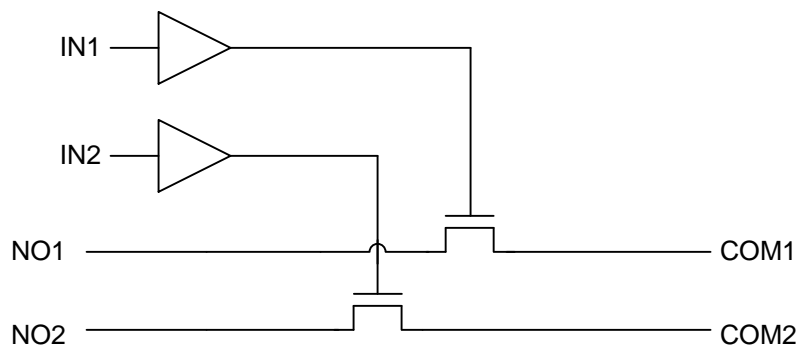

## Table of Contents

<b>1 Features</b> ..... 1 <b>2 Applications</b> ..... 1 <b>3 Description</b> ..... 1 <b>4 Revision History</b> ..... 2 <b>5 Pin Configuration and Functions</b> ..... 3 <b>6 Specifications</b> ..... 3 6.1 Absolute Maximum Ratings ..... 3 6.2 ESD Ratings ..... 4 6.3 Recommended Operating Conditions ..... 4 6.4 Thermal Information ..... 4 6.5 Electrical Characteristics: 5-V Supply ..... 4 6.6 Electrical Characteristics: 3.3-V Supply ..... 6 6.7 Electrical Characteristics: 2.5-V Supply ..... 7 6.8 Electrical Characteristics: 1.8-V Supply ..... 9 6.9 Switching Characteristics: 5-V Supply ..... 10 6.10 Switching Characteristics: 3.3-V Supply ..... 10 6.11 Switching Characteristics: 2.5-V Supply ..... 11 6.12 Switching Characteristics: 1.8-V Supply ..... 11 6.13 Typical Characteristics ..... 12 <b>7 Parameter Measurement Information</b> ..... 14	<b>8 Detailed Description</b> ..... 18 8.1 Overview ..... 18 8.2 Functional Block Diagram ..... 18 8.3 Feature Description ..... 18 8.4 Device Functional Modes ..... 18 <b>9 Application and Implementation</b> ..... 19 9.1 Application Information ..... 19 9.2 Typical Application ..... 19 <b>10 Power Supply Recommendations</b> ..... 20 <b>11 Layout</b> ..... 20 11.1 Layout Guidelines ..... 20 11.2 Layout Example ..... 20 <b>12 Device and Documentation Support</b> ..... 21 12.1 Device Support ..... 21 12.2 Community Resources ..... 22 12.3 Trademarks ..... 22 12.4 Electrostatic Discharge Caution ..... 22 12.5 Glossary ..... 22 <b>13 Mechanical, Packaging, and Orderable Information</b> ..... 22
---	---

## 4 Revision History

NOTE: Page numbers for previous revisions may differ from page numbers in the current version.

Changes from Revision G (February 2013) to Revision H	Page
• Added <i>Pin Configuration and Functions</i> section, <i>ESD Ratings</i> table, <i>Feature Description</i> section, <i>Device Functional Modes</i> , <i>Application and Implementation</i> section, <i>Power Supply Recommendations</i> section, <i>Layout</i> section, <i>Device and Documentation Support</i> section, and <i>Mechanical, Packaging, and Orderable Information</i> section	1
• Updated document to new TI data sheet format - no specification changes.	1
• Removed <i>Ordering Information</i> table.	1

Changes from Revision F (September 2012) to Revision G	Page
• Changed pin numbers for YZT or YZP package pinout.	3

## 5 Pin Configuration and Functions

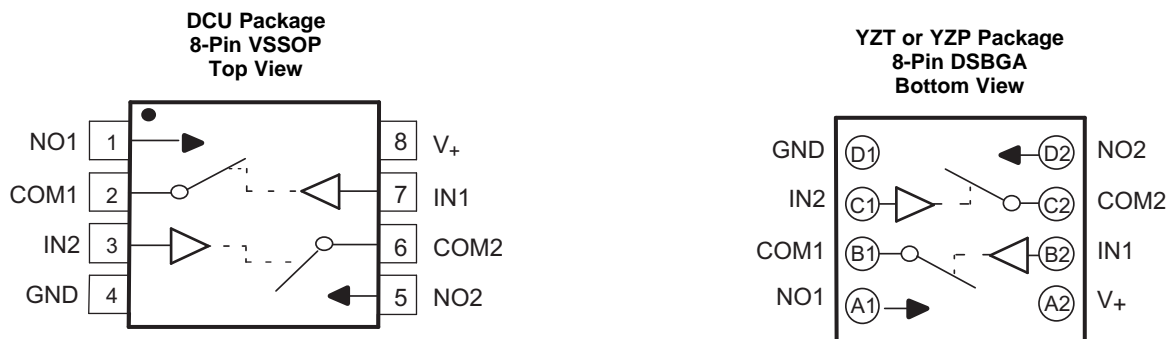

### Pin Functions

PIN			TYPE	DESCRIPTION
NAME	TSSOP NO.	DSBGA NO.		
COM1	2	B1	I/O	Common port for switch 1
COM2	6	C2	I/O	Common port for switch 2
GND	4	D1	GND	Ground
IN1	7	B2	I	Active-high control pin connecting NO1 to COM1.
IN2	3	C1	I	Active-high control pin connecting NO2 to COM2.
NO1	1	A1	I/O	Normally open switch path 1
NO2	5	D2	I/O	Normally open switch path 2
V+	8	A2	PWR	Power supply pin

## 6 Specifications

### 6.1 Absolute Maximum Ratings

over operating free-air temperature range (unless otherwise noted)<sup>(1)(2)</sup>

		MIN	MAX	UNIT
V <sub>+</sub>	Supply voltage <sup>(3)</sup>	-0.5	6.5	V
V <sub>NO</sub> V <sub>COM</sub>	Analog voltage <sup>(3)(4)(5)</sup>	-0.5	V <sub>+</sub> + 0.5	V
I <sub>K</sub>	Analog port diode current	V <sub>NO</sub> , V <sub>COM</sub> < 0		mA
I <sub>NO</sub>	ON-state switch current	V <sub>NO</sub> , V <sub>COM</sub> = 0 to V <sub>+</sub>		mA
I <sub>COM</sub>	ON-state peak switch current <sup>(6)</sup>	V <sub>NO</sub> , V <sub>COM</sub> = 0 to V <sub>+</sub>		mA
V <sub>I</sub>	Digital input voltage <sup>(3)(4)</sup>	-0.5	6.5	V
I <sub>IK</sub>	Digital input clamp current	V <sub>I</sub> < 0		mA
I <sub>+</sub>	Continuous current through V <sub>+</sub>		100	mA
I <sub>GND</sub>	Continuous current through GND	-100	100	mA

- (1) Stresses beyond those listed under *Absolute Maximum Ratings* may cause permanent damage to the device. These are stress ratings only, and functional operation of the device at these or any other conditions beyond those indicated under *Recommended Operating Conditions* is not implied. Exposure to absolute-maximum-rated conditions for extended periods may affect device reliability.
- (2) The algebraic convention, whereby the most negative value is a minimum and the most positive value is a maximum.
- (3) All voltages are with respect to ground, unless otherwise specified.
- (4) The input and output voltage ratings may be exceeded if the input and output clamp-current ratings are observed.
- (5) This value is limited to 5.5 V maximum.
- (6) Pulse at 1-ms duration < 10% duty cycle.

## 6.2 ESD Ratings

		VALUE	UNIT
$V_{(ESD)}$ Electrostatic discharge	Human body model (HBM), per ANSI/ESDA/JEDEC JS-001 <sup>(1)</sup>	+2000	V
	Charged-device model (CDM), per JEDEC specification JESD22-C101 <sup>(2)</sup>	+1000	

(1) JEDEC document JEP155 states that 500-V HBM allows safe manufacturing with a standard ESD control process.

(2) JEDEC document JEP157 states that 250-V CDM allows safe manufacturing with a standard ESD control process.

## 6.3 Recommended Operating Conditions

over operating free-air temperature range (unless otherwise noted)

		MIN	MAX	UNIT
$V_{I/O}$	Input/output voltage	0	$V_+$	V
$V_+$	Supply voltage	1.65	5.5	V
$V_I$	Control Input Voltage	0	5.5	V
$T_A$	Operating free-air temperature	–40	85	°C

## 6.4 Thermal Information

THERMAL METRIC <sup>(1)</sup>	TS5A23166			UNIT
	DCU (VSSOP)	YZP (DSBGA)	YZT (DSBGA)	
	8 PINS	8 PINS	8 PINS	
$R_{\theta JA}$ Junction-to-ambient thermal resistance	227	102	102	°C/W

(1) For more information about traditional and new thermal metrics, see the *IC Package Thermal Metrics* application report, [SPRA953](#).

## 6.5 Electrical Characteristics: 5-V Supply

$V_+ = 4.5\text{ V to }5.5\text{ V}$ ,  $T_A = -40^\circ\text{C to }85^\circ\text{C}$  (unless otherwise noted)<sup>(1)</sup>

PARAMETER	TEST CONDITIONS	$T_A$	$V_+$	MIN	TYP	MAX	UNIT
<b>Analog Switch</b>							
$V_{COM}, V_{NO}$	Analog signal			0		$V_+$	V
$r_{peak}$	Peak ON resistance	$0 \leq V_{NO} \leq V_+$ , $I_{COM} = -100\text{ mA}$ , Switch ON, see <a href="#">Figure 11</a>	25°C Full	4.5 V	0.9	1.1 1.2	$\Omega$
$r_{on}$	ON-state resistance	$V_{NO} = 2.5\text{ V}$ , $I_{COM} = -100\text{ mA}$ , Switch ON, see <a href="#">Figure 11</a>	25°C Full	4.5 V	0.75	0.9 1	$\Omega$
$\Delta r_{on}$	ON-state resistance match between channels	$V_{NO} = 2.5\text{ V}$ , $I_{COM} = -100\text{ mA}$ , Switch ON, see <a href="#">Figure 11</a>	25°C Full	4.5 V	0.04	0.1 0.1	$\Omega$
$r_{on(flat)}$	ON-state resistance flatness	$0 \leq V_{NO} \leq V_+$ , $I_{COM} = -100\text{ mA}$ , Switch ON, see <a href="#">Figure 11</a>	25°C Full	4.5 V	0.2	0.15 0.25 0.25	$\Omega$
$I_{NO(OFF)}$	NO OFF leakage current	$V_{NO} = 1\text{ V}$ , $V_{COM} = 4.5\text{ V}$ , or $V_{NO} = 4.5\text{ V}$ , $V_{COM} = 1\text{ V}$ , Switch OFF, see <a href="#">Figure 12</a>	25°C Full	5.5 V	0 V	4 150	nA
$I_{NO(PWROFF)}$		$V_{NO} = 0\text{ to }5.5\text{ V}$ , $V_{COM} = 5.5\text{ V to }0$ , Switch OFF, see <a href="#">Figure 12</a>	25°C Full	0 V	–10 –50	0.2 50	$\mu\text{A}$

(1) The algebraic convention, whereby the most negative value is a minimum and the most positive value is a maximum.

**Electrical Characteristics: 5-V Supply (continued)**
 $V_+ = 4.5\text{ V to }5.5\text{ V}$ ,  $T_A = -40^\circ\text{C to }85^\circ\text{C}$  (unless otherwise noted)<sup>(1)</sup>

PARAMETER		TEST CONDITIONS		$T_A$	$V_+$	MIN	TYP	MAX	UNIT
$I_{\text{COM(OFF)}}$	COM OFF leakage current	$V_{\text{COM}} = 1\text{ V}$ , $V_{\text{NO}} = 4.5\text{ V}$ , or $V_{\text{COM}} = 4.5\text{ V}$ , $V_{\text{NO}} = 1\text{ V}$ ,	Switch OFF, see <a href="#">Figure 12</a>	25°C	5.5 V	0 V	4	20	nA
				Full		-150		150	
$I_{\text{COM(PWROFF)}}$		$V_{\text{COM}} = 0\text{ to }5.5\text{ V}$ , $V_{\text{NO}} = 5.5\text{ V to }0$ ,	Switch OFF, see <a href="#">Figure 12</a>	25°C	0 V	-10	0.2	10	μA
				Full		-50		50	
$I_{\text{NO(ON)}}$	NO ON leakage current	$V_{\text{NO}} = 1\text{ V}$ , $V_{\text{COM}} = \text{Open}$ , or $V_{\text{NO}} = 4.5\text{ V}$ , $V_{\text{COM}} = \text{Open}$ ,	Switch ON, see <a href="#">Figure 13</a>	25°C	5.5 V	-5	0.4	5	nA
				Full		-50		50	
$I_{\text{COM(ON)}}$	COM ON leakage current	$V_{\text{COM}} = 1\text{ V}$ , $V_{\text{NO}} = \text{Open}$ , or $V_{\text{COM}} = 4.5\text{ V}$ , $V_{\text{NO}} = \text{Open}$ ,	Switch ON, see <a href="#">Figure 13</a>	25°C	5.5 V	-5	0.4	5	nA
				Full		-50		50	
<b>Digital Control Inputs (IN1, IN2)<sup>(2)</sup></b>									
$V_{\text{IH}}$	Input logic high			Full		2.4		5.5	V
$V_{\text{IL}}$	Input logic low			Full		0		0.8	V
$I_{\text{IH}}, I_{\text{IL}}$	Input leakage current	$V_I = 5.5\text{ V or }0$		25°C	5.5 V	-2	0.3	2	nA
				Full		-20		20	
<b>Dynamic</b>									
$Q_C$	Charge injection	$V_{\text{GEN}} = 0$ , $R_{\text{GEN}} = 0$ ,	$C_L = 1\text{ nF}$ , see <a href="#">Figure 19</a>	25°C	5 V		6		pC
$C_{\text{NO(OFF)}}$	NO OFF capacitance	$V_{\text{NO}} = V_+ \text{ or GND}$ , Switch OFF,	See <a href="#">Figure 14</a>	25°C	5 V		19		pF
$C_{\text{COM(OFF)}}$	COM OFF capacitance	$V_{\text{COM}} = V_+ \text{ or GND}$ , Switch OFF,	See <a href="#">Figure 14</a>	25°C	5 V		18		pF
$C_{\text{NO(ON)}}$	NO ON capacitance	$V_{\text{NO}} = V_+ \text{ or GND}$ , Switch ON,	See <a href="#">Figure 14</a>	25°C	5 V		35.5		pF
$C_{\text{COM(ON)}}$	COM ON capacitance	$V_{\text{COM}} = V_+ \text{ or GND}$ , Switch ON,	See <a href="#">Figure 14</a>	25°C	5 V		35.5		pF
$C_I$	Digital input capacitance	$V_I = V_+ \text{ or GND}$ ,	See <a href="#">Figure 14</a>	25°C	5 V		2		pF
BW	Bandwidth	$R_L = 50\ \Omega$ , Switch ON,	See <a href="#">Figure 16</a>	25°C	5 V		150		MHz
$O_{\text{ISO}}$	OFF isolation	$R_L = 50\ \Omega$ , $f = 1\text{ MHz}$ ,	Switch OFF, see <a href="#">Figure 17</a>	25°C	5 V		-62		dB
$X_{\text{TALK}}$	Crosstalk	$R_L = 50\ \Omega$ , $f = 1\text{ MHz}$ ,	Switch ON, see <a href="#">Figure 18</a>	25°C	5 V		-85		dB
THD	Total harmonic distortion	$R_L = 600\ \Omega$ , $C_L = 50\text{ pF}$ ,	$f = 20\text{ Hz to }20\text{ kHz}$ , see <a href="#">Figure 20</a>	25°C	5 V		0.00 5%		

(2) All unused digital inputs of the device must be held at  $V_+$  or GND to ensure proper device operation. Refer to the TI application report, *Implications of Slow or Floating CMOS Inputs*, literature number [SCBA004](#).

**Electrical Characteristics: 5-V Supply (continued)**
 $V_+ = 4.5\text{ V to }5.5\text{ V}$ ,  $T_A = -40^\circ\text{C to }85^\circ\text{C}$  (unless otherwise noted)<sup>(1)</sup>

PARAMETER		TEST CONDITIONS		$T_A$	$V_+$	MIN	TYP	MAX	UNIT
<b>Supply</b>									
$I_+$	Positive supply current	$V_I = V_+$ or GND,	Switch ON or OFF	25°C	5.5 V	0.01	0.1	1	$\mu\text{A}$
				Full					

**6.6 Electrical Characteristics: 3.3-V Supply**
 $V_+ = 3\text{ V to }3.6\text{ V}$ ,  $T_A = -40^\circ\text{C to }85^\circ\text{C}$  (unless otherwise noted)<sup>(1)</sup>

PARAMETER		TEST CONDITIONS		$T_A$	$V_+$	MIN	TYP	MAX	UNIT
<b>Analog Switch</b>									
$V_{\text{COM}}, V_{\text{NO}}$	Analog signal range					0		$V_+$	V
$r_{\text{peak}}$	Peak ON resistance	$0 \leq V_{\text{NO}} \leq V_+$ , $I_{\text{COM}} = -100\text{ mA}$ ,	Switch ON, see <a href="#">Figure 11</a>	25°C	3 V	1.3	1.6	1.8	$\Omega$
				Full					
$r_{\text{on}}$	ON-state resistance	$V_{\text{NO}} = 2\text{ V}$ , $I_{\text{COM}} = -100\text{ mA}$ ,	Switch ON, see <a href="#">Figure 11</a>	25°C	3 V	1.1	1.5	1.7	$\Omega$
				Full					
$\Delta r_{\text{on}}$	ON-state resistance match between channels	$V_{\text{NO}} = 2\text{ V}, 0.8\text{ V}$ , $I_{\text{COM}} = -100\text{ mA}$ ,	Switch ON, see <a href="#">Figure 11</a>	25°C	3 V	0.04	0.1	0.1	$\Omega$
				Full					
$r_{\text{on(flat)}}$	ON-state resistance flatness	$0 \leq V_{\text{NO}} \leq V_+$ , $I_{\text{COM}} = -100\text{ mA}$	Switch ON, see <a href="#">Figure 11</a>	25°C	3 V	0.3	0.15	0.25	$\Omega$
				25°C					
				Full					
$I_{\text{NO(OFF)}}$	NO OFF leakage current	$V_{\text{NO}} = 1\text{ V}, V_{\text{COM}} = 3\text{ V}$ , or $V_{\text{NO}} = 3\text{ V}, V_{\text{COM}} = 1\text{ V}$ ,	Switch OFF, see <a href="#">Figure 12</a>	25°C	3.6 V	-5	0.5	5	nA
				Full					
$I_{\text{NO(PWROFF)}}$		$V_{\text{NO}} = 0\text{ to }3.6\text{ V}$ , $V_{\text{COM}} = 3.6\text{ V to }0$ ,	Switch OFF, see <a href="#">Figure 12</a>	25°C	0 V	-5	0.1	5	$\mu\text{A}$
				Full					
$I_{\text{COM(OFF)}}$	COM OFF leakage current	$V_{\text{COM}} = 1\text{ V}, V_{\text{NO}} = 3\text{ V}$ , or $V_{\text{COM}} = 3\text{ V}, V_{\text{NO}} = 1\text{ V}$ ,	Switch OFF, see <a href="#">Figure 12</a>	25°C	3.6 V	-5	0.5	5	nA
				Full					
$I_{\text{COM(PWROFF)}}$		$V_{\text{COM}} = 0\text{ to }3.6\text{ V}$ , $V_{\text{NO}} = 3.6\text{ V to }0$ ,	Switch OFF, see <a href="#">Figure 12</a>	25°C	0 V	-5	0.1	5	$\mu\text{A}$
				Full					
$I_{\text{NO(ON)}}$	NO ON leakage current	$V_{\text{NO}} = 1\text{ V}$ , $V_{\text{COM}} = \text{Open}$ , or $V_{\text{NO}} = 3\text{ V}$ , $V_{\text{COM}} = \text{Open}$ ,	Switch ON, see <a href="#">Figure 13</a>	25°C	3.6 V	-2	0.3	2	nA
				Full					
$I_{\text{COM(ON)}}$	COM ON leakage current	$V_{\text{COM}} = 1\text{ V}$ , $V_{\text{NO}} = \text{Open}$ , or $V_{\text{COM}} = 3\text{ V}$ , $V_{\text{NO}} = \text{Open}$ ,	Switch ON, see <a href="#">Figure 13</a>	25°C	3.6 V	-2	0.3	2	nA
				Full					
<b>Digital Control Inputs (IN1, IN2)<sup>(2)</sup></b>									
$V_{\text{IH}}$	Input logic high			Full		2		5.5	V
$V_{\text{IL}}$	Input logic low			Full		0		0.8	V
$I_{\text{IH}}, I_{\text{IL}}$	Input leakage current	$V_I = 5.5\text{ V or }0$		25°C	3.6 V	-2	0.3	2	nA
				Full					

(1) The algebraic convention, whereby the most negative value is a minimum and the most positive value is a maximum.

(2) All unused digital inputs of the device must be held at  $V_+$  or GND to ensure proper device operation. Refer to the TI application report, *Implications of Slow or Floating CMOS Inputs*, literature number [SCBA004](#).

**Electrical Characteristics: 3.3-V Supply (continued)**
 $V_+ = 3\text{ V to }3.6\text{ V}$ ,  $T_A = -40^\circ\text{C to }85^\circ\text{C}$  (unless otherwise noted)<sup>(1)</sup>

PARAMETER		TEST CONDITIONS		$T_A$	$V_+$	MIN	TYP	MAX	UNIT
<b>Dynamic</b>									
$Q_C$	Charge injection	$V_{GEN} = 0$ , $R_{GEN} = 0$ ,	$C_L = 1\text{ nF}$ , see <a href="#">Figure 19</a>	25°C	5 V		6		pC
$C_{NO(OFF)}$	NO OFF capacitance	$V_{NO} = V_+$ or GND, Switch OFF,	See <a href="#">Figure 14</a>	25°C	3.3 V		19.5		pF
$C_{COM(OFF)}$	COM OFF capacitance	$V_{COM} = V_+$ or GND, Switch OFF,	See <a href="#">Figure 14</a>	25°C	3.3 V		18.5		pF
$C_{NO(ON)}$	NO ON capacitance	$V_{NO} = V_+$ or GND, Switch ON,	See <a href="#">Figure 14</a>	25°C	3.3 V		36		pF
$C_{COM(ON)}$	COM ON capacitance	$V_{COM} = V_+$ or GND, Switch ON,	See <a href="#">Figure 14</a>	25°C	3.3 V		36		pF
$C_I$	Digital input capacitance	$V_I = V_+$ or GND,	See <a href="#">Figure 14</a>	25°C	3.3 V		2		pF
BW	Bandwidth	$R_L = 50\ \Omega$ , Switch ON,	See <a href="#">Figure 16</a>	25°C	3.3 V		150		MHz
$O_{ISO}$	OFF isolation	$R_L = 50\ \Omega$ , $f = 1\text{ MHz}$ ,	Switch OFF, see <a href="#">Figure 17</a>	25°C	3.3 V		-62		dB
$X_{TALK}$	Crosstalk	$R_L = 50\ \Omega$ , $f = 1\text{ MHz}$ ,	Switch ON, see <a href="#">Figure 18</a>	25°C	3.3 V		-85		dB
THD	Total harmonic distortion	$R_L = 600\ \Omega$ , $C_L = 50\text{ pF}$ ,	$f = 20\text{ Hz to }20\text{ kHz}$ , see <a href="#">Figure 20</a>	25°C	3.3 V		0.01 %		
<b>Supply</b>									
$I_+$	Positive supply current	$V_I = V_+$ or GND,	Switch ON or OFF	25°C	3.6 V	0.00	1	0.05	$\mu\text{A}$
				Full			0.3		

**6.7 Electrical Characteristics: 2.5-V Supply**
 $V_+ = 2.3\text{ V to }2.7\text{ V}$ ,  $T_A = -40^\circ\text{C to }85^\circ\text{C}$  (unless otherwise noted)<sup>(1)</sup>

PARAMETER		TEST CONDITIONS		$T_A$	$V_+$	MIN	TYP	MAX	UNIT
<b>Analog Switch</b>									
$V_{COM}, V_{NO}$	Analog signal range					0		$V_+$	V
$r_{peak}$	Peak ON resistance	$0 \leq V_{NO} \leq V_+$ , $I_{COM} = -8\text{ mA}$ ,	Switch ON, see <a href="#">Figure 11</a>	25°C	2.3 V	1.8	2.4		$\Omega$
				Full			2.6		
$r_{on}$	ON-state resistance	$V_{NO} = 1.8\text{ V}$ , $I_{COM} = -8\text{ mA}$ ,	Switch ON, see <a href="#">Figure 11</a>	25°C	2.3 V	1.2	2.1		$\Omega$
				Full			2.4		
$\Delta r_{on}$	ON-state resistance match between channels	$V_{NO} = 1.8\text{ V}, 0.8\text{ V}$ , $I_{COM} = -8\text{ mA}$ ,	Switch ON, see <a href="#">Figure 11</a>	25°C	2.3 V	0.04	0.15		$\Omega$
				Full			0.15		
$r_{on(Flat)}$	ON-state resistance flatness	$0 \leq V_{NO} \leq V_+$ , $I_{COM} = -8\text{ mA}$ ,	Switch ON, see <a href="#">Figure 11</a>	25°C	2.3 V	0.7			$\Omega$
				25°C		0.4	0.6		
				Full			0.6		

(1) The algebraic convention is used in this data sheet; the most negative value is shown in the minimum column.

**Electrical Characteristics: 2.5-V Supply (continued)**
 $V_+ = 2.3 \text{ V to } 2.7 \text{ V}$ ,  $T_A = -40^\circ\text{C to } 85^\circ\text{C}$  (unless otherwise noted)<sup>(1)</sup>

PARAMETER		TEST CONDITIONS		$T_A$	$V_+$	MIN	TYP	MAX	UNIT
$I_{\text{NO(OFF)}}$	NO OFF leakage current	$V_{\text{NO}} = 0.5 \text{ V}$ , $V_{\text{COM}} = 2.3 \text{ V}$ , or $V_{\text{NO}} = 2.3 \text{ V}$ , $V_{\text{COM}} = 0.5 \text{ V}$ ,	Switch OFF, see <a href="#">Figure 12</a>	25°C	2.7 V	-5	0.3	5	nA
				Full		-50		50	
$I_{\text{NO(PWROFF)}}$		$V_{\text{NO}} = 0 \text{ to } 2.7 \text{ V}$ , $V_{\text{COM}} = 2.7 \text{ V to } 0$ ,	Switch OFF, see <a href="#">Figure 12</a>	25°C	0 V	-2	0.05	2	μA
				Full		-15		15	
$I_{\text{COM(OFF)}}$	COM OFF leakage current	$V_{\text{NO}} = 2.3 \text{ V}$ , $V_{\text{COM}} = 0.5 \text{ V}$ , or $V_{\text{NO}} = 0.5 \text{ V}$ , $V_{\text{COM}} = 2.3 \text{ V}$ ,	Switch OFF, see <a href="#">Figure 12</a>	25°C	2.7 V	-5	0.3	5	nA
				Full		-50		50	
$I_{\text{COM(PWROFF)}}$		$V_{\text{COM}} = 0 \text{ to } 2.7 \text{ V}$ , $V_{\text{NO}} = 2.7 \text{ V to } 0$ ,	Switch OFF, see <a href="#">Figure 12</a>	25°C	0 V	-2	0.05	2	μA
				Full		-15		15	
$I_{\text{NO(ON)}}$	NO ON leakage current	$V_{\text{NO}} = 0.5 \text{ V}$ , $V_{\text{COM}} = \text{Open}$ , or $V_{\text{NO}} = 2.3 \text{ V}$ , $V_{\text{COM}} = \text{Open}$ ,	Switch ON, see <a href="#">Figure 13</a>	25°C	2.7 V	-2	0.3	2	nA
				Full		-20		20	
$I_{\text{COM(ON)}}$	COM ON leakage current	$V_{\text{COM}} = 0.5 \text{ V}$ , $V_{\text{NO}} = \text{Open}$ , or $V_{\text{COM}} = 2.3 \text{ V}$ , $V_{\text{NO}} = \text{Open}$ ,	Switch ON, see <a href="#">Figure 13</a>	25°C	2.7 V	-2	0.3	2	nA
				Full		-20		20	
<b>Digital Control Inputs (IN1, IN2)</b>									
$V_{\text{IH}}$	Input logic high			Full		1.8		5.5	V
$V_{\text{IL}}$	Input logic low			Full		0		0.6	V
$I_{\text{IH}}, I_{\text{IL}}$	Input leakage current	$V_{\text{I}} = 5.5 \text{ V or } 0$		25°C	2.7 V	-2	0.3	2	nA
				Full		-20		20	
<b>Dynamic</b>									
$Q_{\text{C}}$	Charge injection	$V_{\text{GEN}} = 0$ , $R_{\text{GEN}} = 0$ ,	$C_{\text{L}} = 1 \text{ nF}$ , see <a href="#">Figure 19</a>	25°C	2.5 V		4		pC
$C_{\text{NO(OFF)}}$	NO OFF capacitance	$V_{\text{NO}} = V_+ \text{ or GND}$ , Switch OFF,	See <a href="#">Figure 14</a>	25°C	2.5 V		19.5		pF
$C_{\text{COM(OFF)}}$	COM OFF capacitance	$V_{\text{COM}} = V_+ \text{ or GND}$ , Switch OFF,	See <a href="#">Figure 14</a>	25°C	2.5 V		18.5		pF
$C_{\text{NO(ON)}}$	NO ON capacitance	$V_{\text{NO}} = V_+ \text{ or GND}$ , Switch ON,	See <a href="#">Figure 14</a>	25°C	2.5 V		36.5		pF
$C_{\text{COM(ON)}}$	COM ON capacitance	$V_{\text{COM}} = V_+ \text{ or GND}$ , Switch ON,	See <a href="#">Figure 14</a>	25°C	2.5 V		36.5		pF
$C_{\text{I}}$	Digital input capacitance	$V_{\text{I}} = V_+ \text{ or GND}$ ,	See <a href="#">Figure 14</a>	25°C	2.5 V		2		pF
BW	Bandwidth	$R_{\text{L}} = 50 \Omega$ , Switch ON,	See <a href="#">Figure 16</a>	25°C	2.5 V		150		MHz
$O_{\text{ISO}}$	OFF isolation	$R_{\text{L}} = 50 \Omega$ , $f = 1 \text{ MHz}$ ,	Switch OFF, see <a href="#">Figure 17</a>	25°C	2.5 V		-62		dB
$X_{\text{TALK}}$	Crosstalk	$R_{\text{L}} = 50 \Omega$ , $f = 1 \text{ MHz}$ ,	Switch ON, see <a href="#">Figure 18</a>	25°C	2.5 V		-85		dB
THD	Total harmonic distortion	$R_{\text{L}} = 600 \Omega$ , $C_{\text{L}} = 50 \text{ pF}$ ,	$f = 20 \text{ Hz to } 20 \text{ kHz}$ , see <a href="#">Figure 20</a>	25°C	2.5 V		0.02%		
<b>Supply</b>									



**Electrical Characteristics: 2.5-V Supply (continued)**
 $V_+ = 2.3 \text{ V to } 2.7 \text{ V}$ ,  $T_A = -40^\circ\text{C to } 85^\circ\text{C}$  (unless otherwise noted)<sup>(1)</sup>

PARAMETER	TEST CONDITIONS	$T_A$	$V_+$	MIN	TYP	MAX	UNIT
$I_+$	Positive supply current $V_I = V_+$ or GND, Switch ON or OFF	25°C	2.7 V	0.001	0.02	0.25	$\mu\text{A}$
		Full					

**6.8 Electrical Characteristics: 1.8-V Supply**
 $V_+ = 1.65 \text{ V to } 1.95 \text{ V}$ ,  $T_A = -40^\circ\text{C to } 85^\circ\text{C}$  (unless otherwise noted)<sup>(1)</sup>

PARAMETER	TEST CONDITIONS	$T_A$	$V_+$	MIN	TYP	MAX	UNIT
<b>Analog Switch</b>							
$V_{\text{COM}}, V_{\text{NO}}$	Analog signal range			0		$V_+$	V
$r_{\text{peak}}$	Peak ON resistance $0 \leq V_{\text{NO}} \leq V_+$ , $I_{\text{COM}} = -2 \text{ mA}$ , Switch ON, see <a href="#">Figure 11</a>	25°C	1.65 V		4.2	25	$\Omega$
		Full					
$r_{\text{on}}$	ON-state resistance $V_{\text{NO}} = 0.6 \text{ V}, 1.5 \text{ V}$ , $I_{\text{COM}} = -2 \text{ mA}$ , Switch ON, see <a href="#">Figure 11</a>	25°C	1.65 V		1.6	3.9	$\Omega$
		Full					
$\Delta r_{\text{on}}$	ON-state resistance match between channels $V_{\text{NO}} = 1.5 \text{ V}$ , $I_{\text{COM}} = -2 \text{ mA}$ , Switch ON, see <a href="#">Figure 11</a>	25°C	1.65 V		0.04	0.2	$\Omega$
		Full					
$r_{\text{on(Flat)}}$	ON-state resistance flatness $0 \leq V_{\text{NO}} \leq V_+$ , $I_{\text{COM}} = -2 \text{ mA}$ , Switch ON, see <a href="#">Figure 11</a>	25°C	1.65 V		2.8	22	$\Omega$
		25°C					
		Full					
$I_{\text{NO(OFF)}}$	NO OFF leakage current $V_{\text{NO}} = 0.3 \text{ V}$ , $V_{\text{COM}} = 1.65 \text{ V}$ , or $V_{\text{NO}} = 1.65 \text{ V}$ , $V_{\text{COM}} = 0.3 \text{ V}$ , Switch OFF, see <a href="#">Figure 12</a>	25°C	1.95 V		-5	0.3	5
		Full					
$I_{\text{NO(PWROFF)}}$	NO OFF leakage current $V_{\text{NO}} = 0 \text{ to } 1.95 \text{ V}$ , $V_{\text{COM}} = 1.95 \text{ V to } 0$ , Switch OFF, see <a href="#">Figure 12</a>	25°C	0 V		-2	0.05	2
		Full					
$I_{\text{COM(OFF)}}$	COM OFF leakage current $V_{\text{NO}} = 1.65 \text{ V}$ , $V_{\text{COM}} = 0.3 \text{ V}$ , or $V_{\text{NO}} = 0.3 \text{ V}$ , $V_{\text{COM}} = 1.65 \text{ V}$ , Switch OFF, see <a href="#">Figure 12</a>	25°C	1.95 V		-5	0.3	5
		Full					
$I_{\text{COM(PWROFF)}}$	COM OFF leakage current $V_{\text{COM}} = 0 \text{ to } 1.95 \text{ V}$ , $V_{\text{NO}} = 1.95 \text{ V to } 0$ , Switch OFF, see <a href="#">Figure 12</a>	25°C	0 V		-2	0.05	2
		Full					
$I_{\text{NO(ON)}}$	NO ON leakage current $V_{\text{NO}} = 0.3 \text{ V}$ , $V_{\text{COM}} = \text{Open}$ , or $V_{\text{NO}} = 1.65 \text{ V}$ , $V_{\text{COM}} = \text{Open}$ , Switch ON, see <a href="#">Figure 13</a>	25°C	1.95 V		-2	0.3	2
		Full					
$I_{\text{COM(ON)}}$	COM ON leakage current $V_{\text{NO}} = \text{Open}$ , $V_{\text{COM}} = 0.3 \text{ V}$ , or $V_{\text{NO}} = \text{Open}$ , $V_{\text{COM}} = 1.65 \text{ V}$ , Switch ON, see <a href="#">Figure 13</a>	25°C	1.95 V		-2	0.3	2
		Full					
<b>Digital Control Inputs (IN1, IN2)</b>							
$V_{\text{IH}}$	Input logic high		Full		1.5	5.5	V
$V_{\text{IL}}$	Input logic low		Full		0	0.6	V
$I_{\text{IH}}, I_{\text{IL}}$	Input leakage current $V_I = 5.5 \text{ V or } 0$	25°C	1.95 V		-2	0.3	2
		Full					
<b>Dynamic</b>							

(1) The algebraic convention is used in this data sheet; the most negative value is shown in the minimum column.

**Electrical Characteristics: 1.8-V Supply (continued)**
 $V_+ = 1.65\text{ V to }1.95\text{ V}$ ,  $T_A = -40^\circ\text{C to }85^\circ\text{C}$  (unless otherwise noted)<sup>(1)</sup>

PARAMETER		TEST CONDITIONS		$T_A$	$V_+$	MIN	TYP	MAX	UNIT
$Q_C$	Charge injection	$V_{GEN} = 0$ , $R_{GEN} = 0$ ,	$C_L = 1\text{ nF}$ , see <a href="#">Figure 19</a>	25°C	1.8 V		2		pC
$C_{NO(OFF)}$	NO OFF capacitance	$V_{NO} = V_+$ or GND, Switch OFF,	See <a href="#">Figure 14</a>	25°C	1.8 V		19.5		pF
$C_{COM(OFF)}$	COM OFF capacitance	$V_{COM} = V_+$ or GND, Switch OFF,	See <a href="#">Figure 14</a>	25°C	1.8 V		18.5		pF
$C_{NO(ON)}$	NO ON capacitance	$V_{NO} = V_+$ or GND, Switch ON,	See <a href="#">Figure 14</a>	25°C	1.8 V		36.5		pF
$C_{COM(ON)}$	COM ON capacitance	$V_{COM} = V_+$ or GND, Switch ON,	See <a href="#">Figure 14</a>	25°C	1.8 V		36.5		pF
$C_I$	Digital input capacitance	$V_I = V_+$ or GND,	See <a href="#">Figure 14</a>	25°C	1.8 V		2		pF
BW	Bandwidth	$R_L = 50\ \Omega$ , Switch ON,	See <a href="#">Figure 16</a>	25°C	1.8 V		150		MHz
$O_{ISO}$	OFF isolation	$R_L = 50\ \Omega$ , $f = 1\text{ MHz}$ ,	Switch OFF, see <a href="#">Figure 17</a>	25°C	1.8 V		-62		dB
THD	Total harmonic distortion	$R_L = 600\ \Omega$ , $C_L = 50\text{ pF}$ ,	$f = 20\text{ Hz to }20\text{ kHz}$ , see <a href="#">Figure 20</a>	25°C	1.8 V		0.055 %		
<b>Supply</b>									
$I_+$	Positive supply current	$V_I = V_+$ or GND,	Switch ON or OFF	25°C	1.95 V		0.001	0.01	$\mu\text{A}$
				Full				0.15	

**6.9 Switching Characteristics: 5-V Supply**
 $V_+ = 4.5\text{ V to }5.5\text{ V}$ ,  $T_A = -40^\circ\text{C to }85^\circ\text{C}$  (unless otherwise noted)<sup>(1)</sup>

PARAMETER		TEST CONDITIONS		$T_A$	$V_+$	MIN	TYP	MAX	UNIT
<b>Dynamic</b>									
$t_{ON}$	Turnon time	$V_{COM} = V_+$ , $R_L = 50\ \Omega$ ,	$C_L = 35\text{ pF}$ , see <a href="#">Figure 15</a>	25°C	5 V	1	4.5	7.5	ns
				Full	4.5 V to 5.5 V	1		9	
$t_{OFF}$	Turnoff time	$V_{COM} = V_+$ , $R_L = 50\ \Omega$ ,	$C_L = 35\text{ pF}$ , see <a href="#">Figure 15</a>	25°C	5 V	4.5	8	11	ns
				Full	4.5 V to 5.5 V	3.5		13	

(1) The algebraic convention is used in this data sheet; the most negative value is shown in the minimum column.

**6.10 Switching Characteristics: 3.3-V Supply**
 $V_+ = 3\text{ V to }3.6\text{ V}$ ,  $T_A = -40^\circ\text{C to }85^\circ\text{C}$  (unless otherwise noted)<sup>(1)</sup>

PARAMETER		TEST CONDITIONS		$T_A$	$V_+$	MIN	TYP	MAX	UNIT
<b>Dynamic</b>									
$t_{ON}$	Turnon time	$V_{COM} = V_+$ , $R_L = 50\ \Omega$ ,	$C_L = 35\text{ pF}$ , see <a href="#">Figure 15</a>	25°C	3.3 V	1.5	5	9.5	ns
				Full	3 V to 3.6 V	1		10	
$t_{OFF}$	Turnoff time	$V_{COM} = V_+$ , $R_L = 50\ \Omega$ ,	$C_L = 35\text{ pF}$ , see <a href="#">Figure 15</a>	25°C	3.3 V	4.5	8.5	11	ns
				Full	3 V to 3.6 V	3		12.5	

(1) The algebraic convention is used in this data sheet; the most negative value is shown in the minimum column.

### 6.11 Switching Characteristics: 2.5-V Supply

 $V_+ = 2.3\text{ V to }2.7\text{ V}$ ,  $T_A = -40^\circ\text{C to }85^\circ\text{C}$  (unless otherwise noted)<sup>(1)</sup>

PARAMETER		TEST CONDITIONS		$T_A$	$V_+$	MIN	TYP	MAX	UNIT
<b>Dynamic</b>									
$t_{ON}$	Turnon time	$V_{COM} = V_+$ , $R_L = 50\ \Omega$ ,	$C_L = 35\text{ pF}$ , see <a href="#">Figure 15</a>	25°C	2.5 V	2	6	10	ns
				Full	2.3 V to 2.7 V	1		12	
$t_{OFF}$	Turnoff time	$V_{COM} = V_+$ , $R_L = 50\ \Omega$ ,	$C_L = 35\text{ pF}$ , see <a href="#">Figure 15</a>	25°C	2.5 V	4.5	8	12.5	ns
				Full	2.3 V to 2.7 V	3		15	

(1) The algebraic convention is used in this data sheet; the most negative value is shown in the minimum column.

### 6.12 Switching Characteristics: 1.8-V Supply

 $V_+ = 1.65\text{ V to }1.95\text{ V}$ ,  $T_A = -40^\circ\text{C to }85^\circ\text{C}$  (unless otherwise noted)<sup>(1)</sup>

PARAMETER		TEST CONDITIONS		$T_A$	$V_+$	MIN	TYP	MAX	UNIT
<b>Dynamic</b>									
$t_{ON}$	Turnon time	$V_{COM} = V_+$ , $R_L = 50\ \Omega$ ,	$C_L = 35\text{ pF}$ , see <a href="#">Figure 15</a>	25°C	1.8 V	3	9	18	ns
				Full	1.65 V to 1.95 V	1		20	
$t_{OFF}$	Turnoff time	$V_{COM} = V_+$ , $R_L = 50\ \Omega$ ,	$C_L = 35\text{ pF}$ , see <a href="#">Figure 15</a>	25°C	1.8 V	5	10	15.5	ns
				Full	1.65 V to 1.95 V	4		18.5	

(1) The algebraic convention is used in this data sheet; the most negative value is shown in the minimum column.

### 6.13 Typical Characteristics

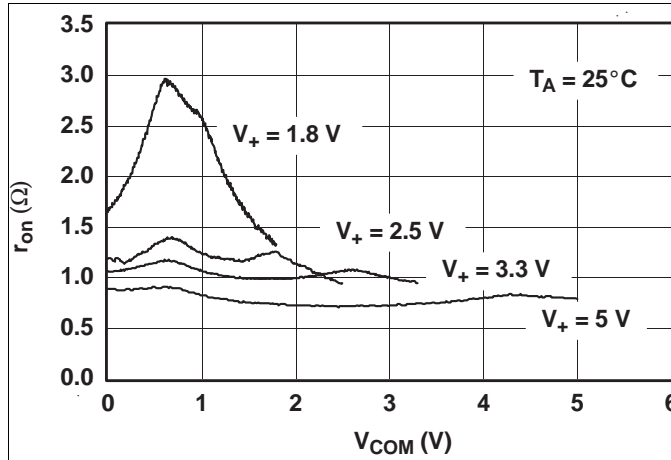
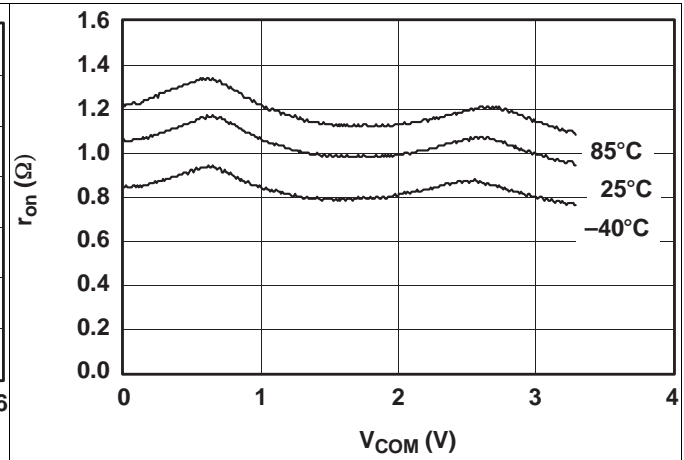
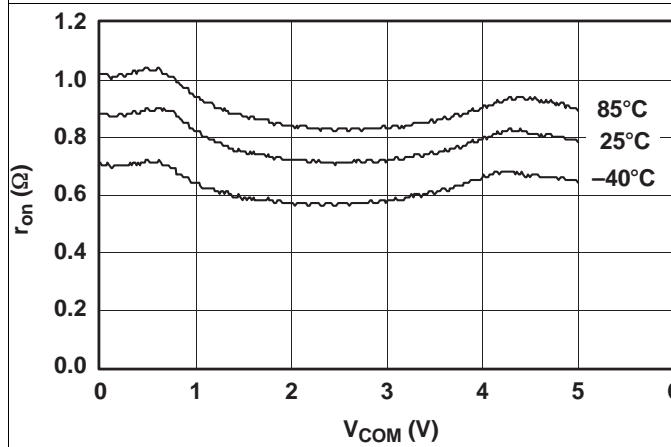
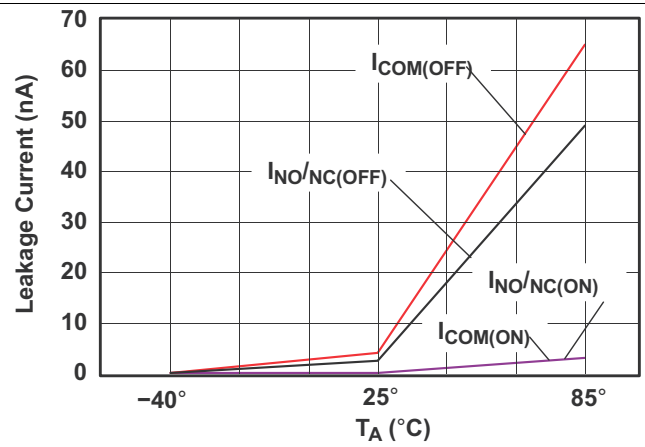
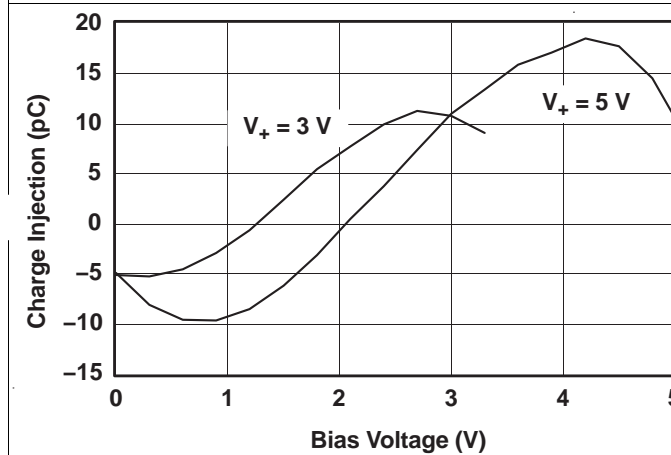
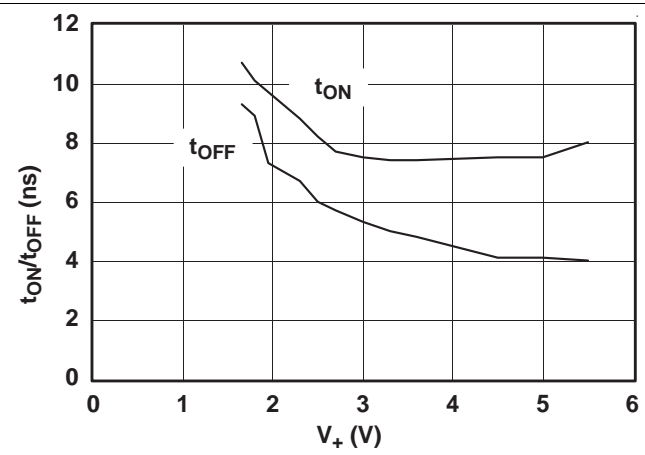
 Figure 1.  $r_{on}$  vs  $V_{COM}$ 

 Figure 2.  $r_{on}$  vs  $V_{COM}$  ( $V_+ = 3.3$  V)

 Figure 3.  $r_{on}$  vs  $V_{COM}$  ( $V_+ = 5$  V)

 Figure 4. Leakage Current vs Temperature ( $V_+ = 5.5$  V)

 Figure 5. Charge Injection ( $Q_C$ ) vs  $V_{COM}$ 

 Figure 6.  $t_{ON}$  and  $t_{OFF}$  vs Supply Voltage

Typical Characteristics (continued)

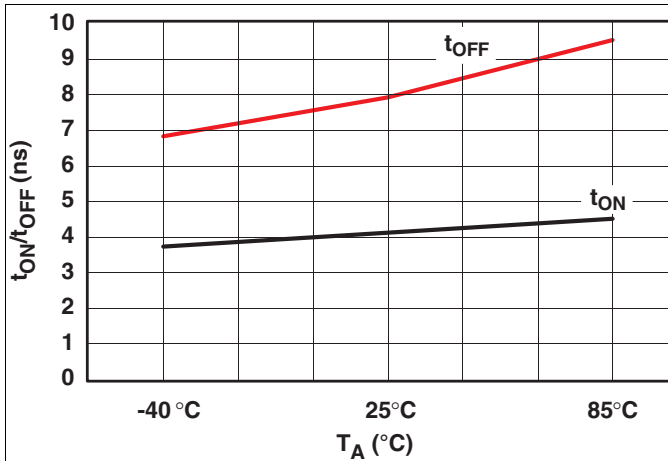

Figure 7. t<sub>ON</sub> and t<sub>OFF</sub> vs Temperature (V<sub>+</sub> = 5 V)

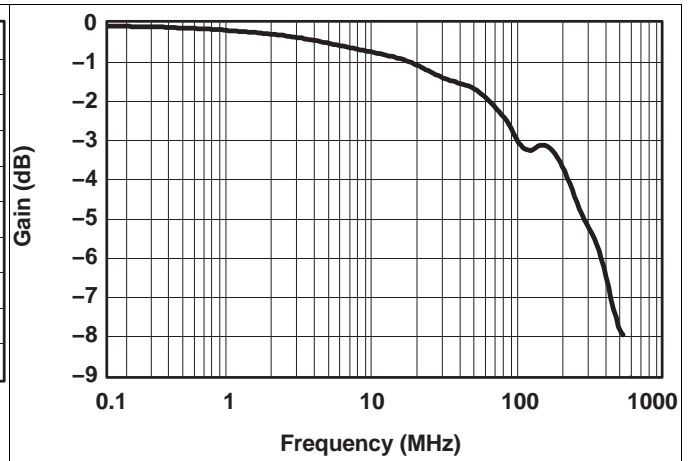

Figure 8. Bandwidth (V<sub>+</sub> = 5 V)

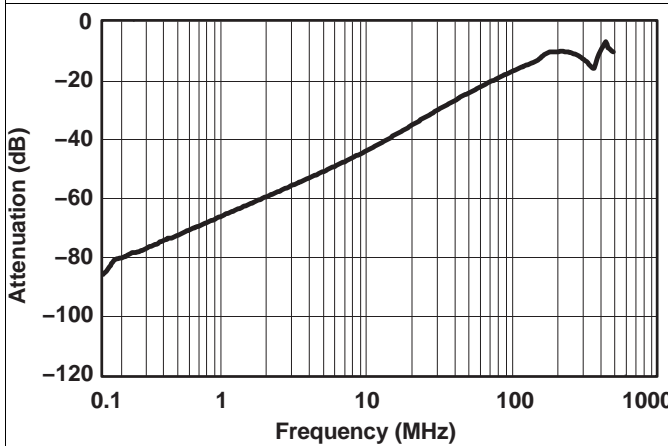

Figure 9. OFF Isolation and Crosstalk (V<sub>+</sub> = 5 V)

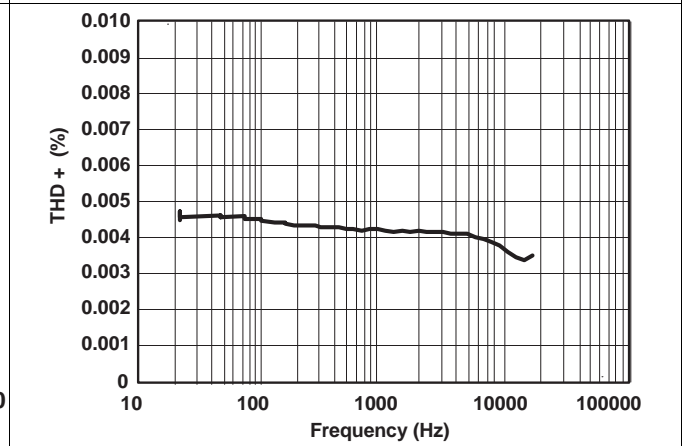

Figure 10. Total Harmonic Distortion vs Frequency

## 7 Parameter Measurement Information

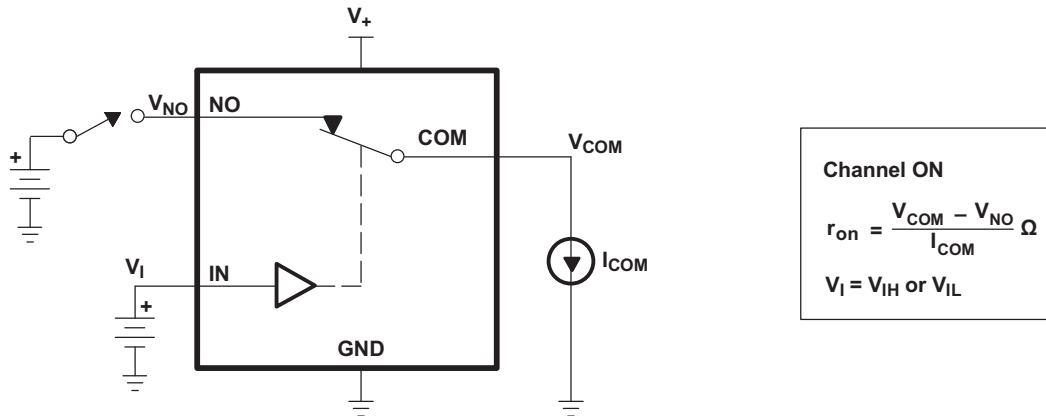

Figure 11. ON-State Resistance ( $r_{on}$ )

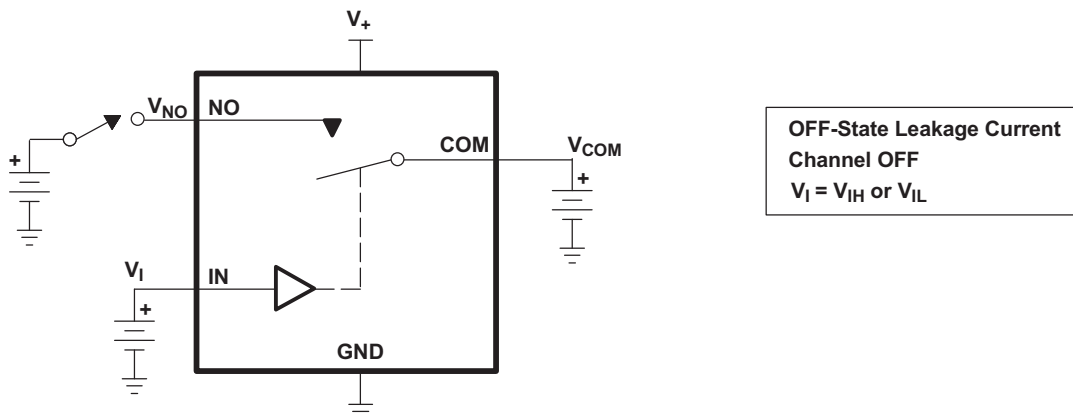

Figure 12. OFF-State Leakage Current ( $I_{COM(OFF)}$ ,  $I_{NC(OFF)}$ ,  $I_{COM(PWROFF)}$ ,  $I_{NC(PWRFF)}$ )

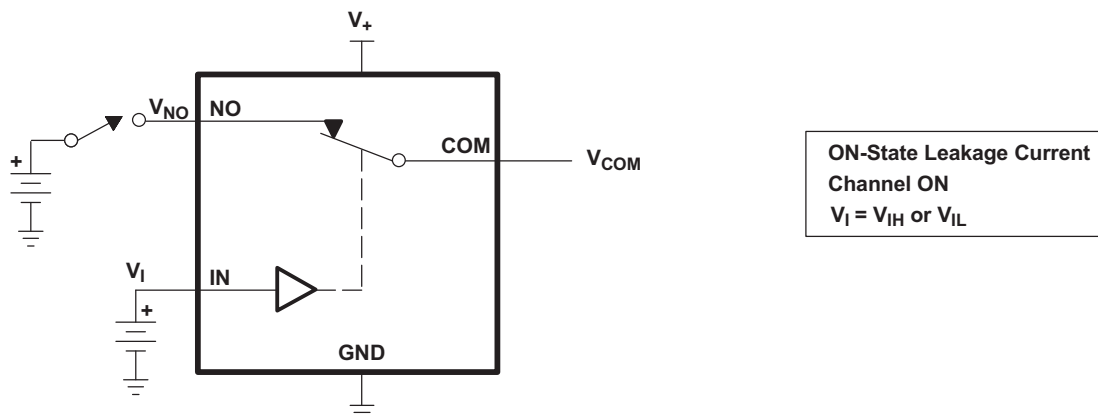

Figure 13. ON-State Leakage Current ( $I_{COM(ON)}$ ,  $I_{NC(ON)}$ )

Parameter Measurement Information (continued)

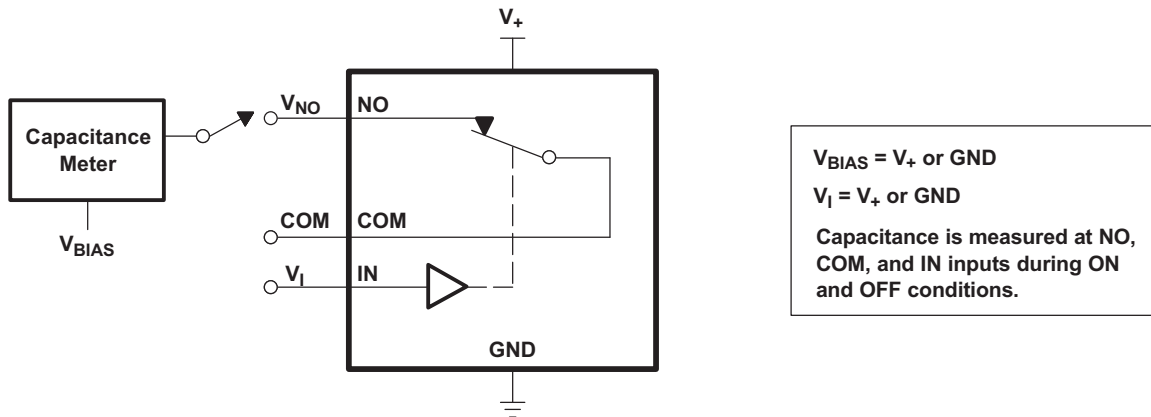
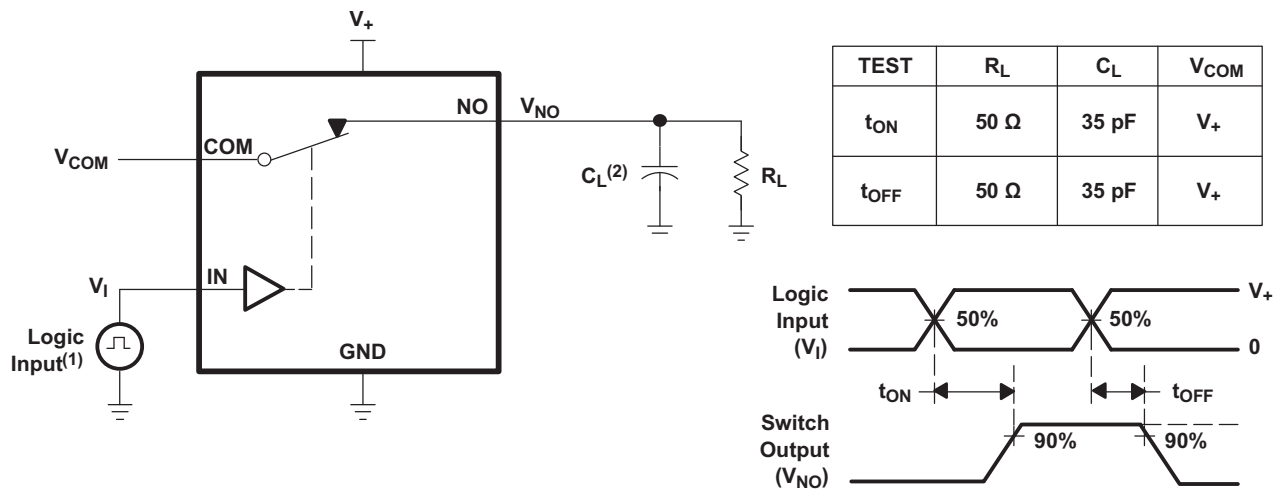

Figure 14. Capacitance ( $C_I$ ,  $C_{COM(OFF)}$ ,  $C_{COM(ON)}$ ,  $C_{NC(OFF)}$ ,  $C_{NC(ON)}$ )



- (1) All input pulses are supplied by generators having the following characteristics: PRR  $\leq$  10 MHz,  $Z_O = 50 \Omega$ ,  $t_r < 5$  ns,  $t_f < 5$  ns.
- (2)  $C_L$  includes probe and jig capacitance.

Figure 15. Turnon ( $t_{ON}$ ) and Turnoff Time ( $t_{OFF}$ )

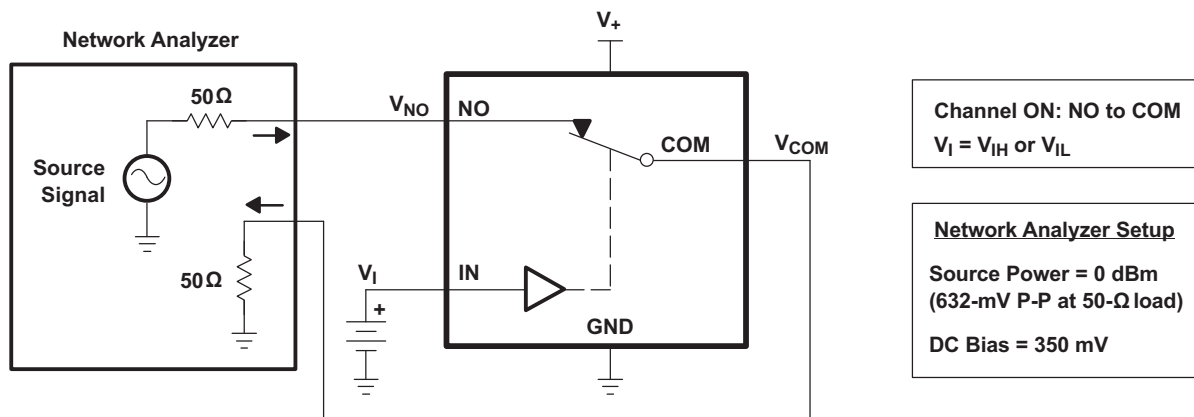

Figure 16. Bandwidth (BW)

Parameter Measurement Information (continued)

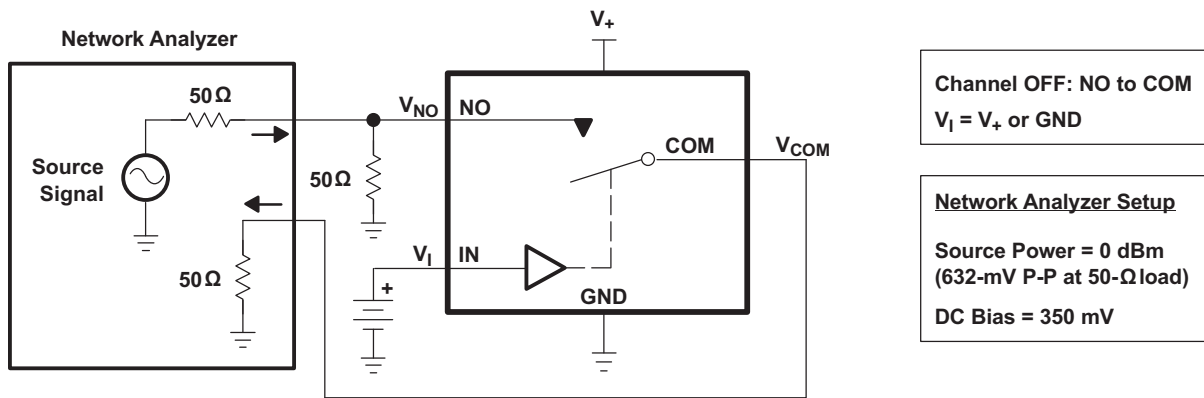

Figure 17. OFF Isolation ( $O_{ISO}$ )

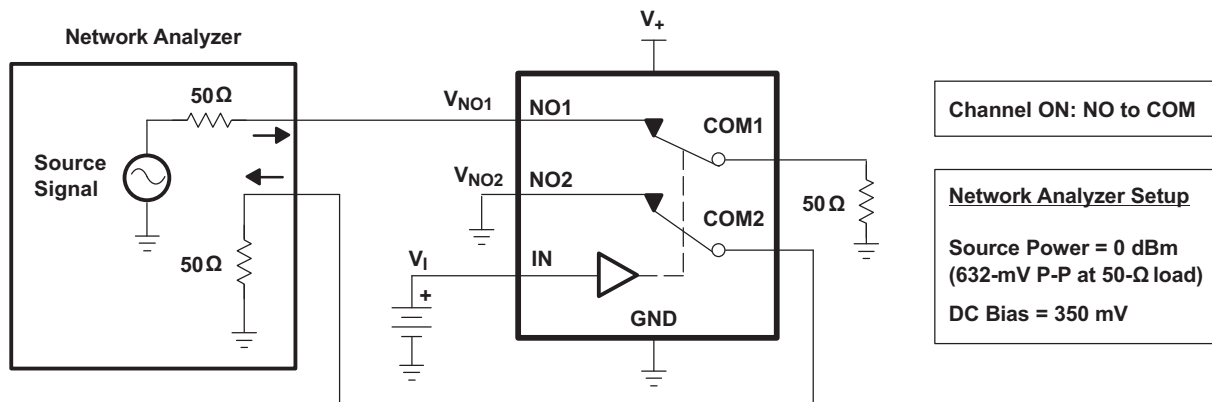
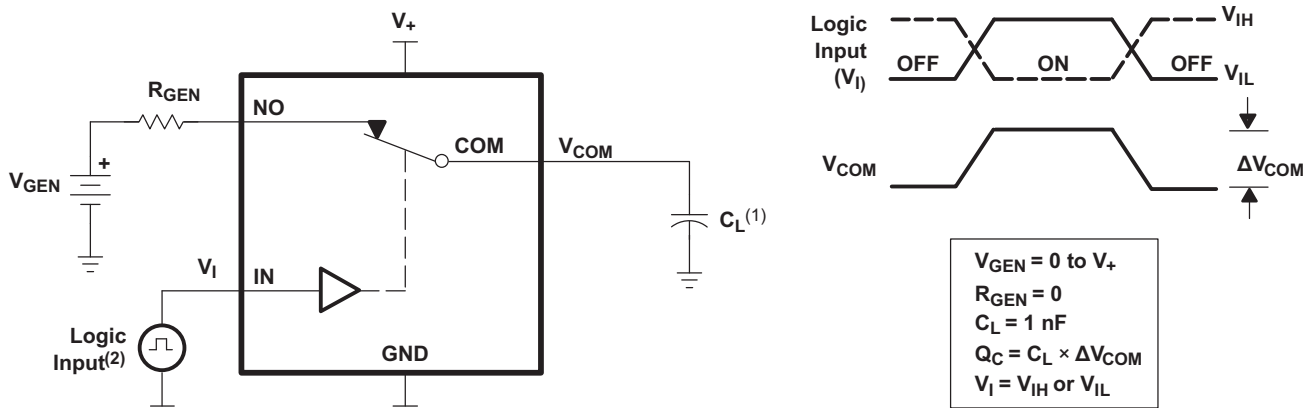

Figure 18. Crosstalk ( $X_{TALK}$ )



- (1)  $C_L$  includes probe and jig capacitance.
- (2) All input pulses are supplied by generators having the following characteristics:  
 $PRR \leq 10 \text{ MHz}$ ,  $Z_O = 50 \Omega$ ,  $t_r < 5 \text{ ns}$ ,  $t_f < 5 \text{ ns}$ .

Figure 19. Charge Injection ( $Q_C$ )



Parameter Measurement Information (continued)

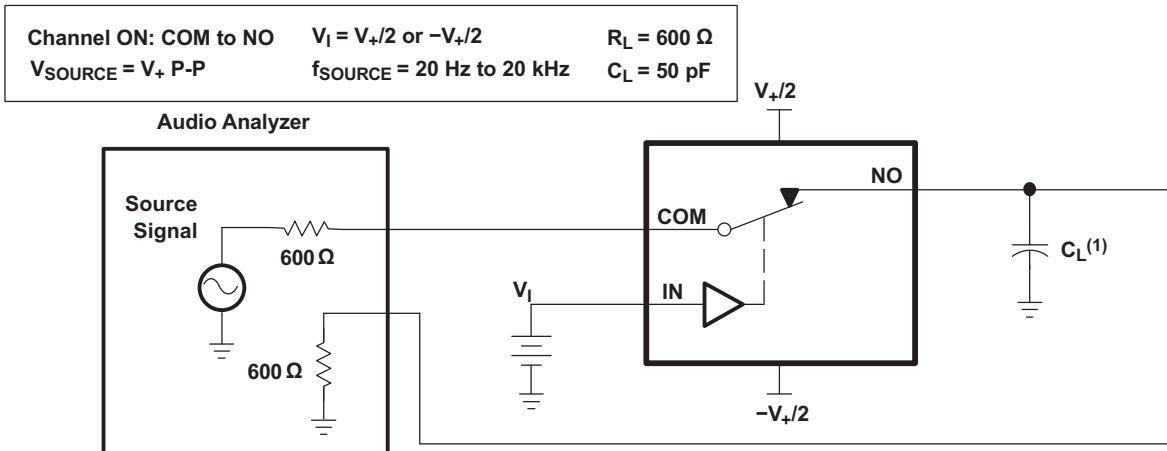

(1)  $C_L$  includes probe and jig capacitance.

Figure 20. Total Harmonic Distortion (THD)

## 8 Detailed Description

### 8.1 Overview

The TS5A23166 is a dual single-pole single-throw (SPST) analog switch that is designed to operate from 1.65 V to 5.5 V. The device offers a low ON-state resistance. The device has excellent total harmonic distortion (THD) performance and consumes very low power. These features make this device suitable for portable audio applications. [Table 2](#) shows the descriptions of each parameter specified in the datasheet.

### 8.2 Functional Block Diagram

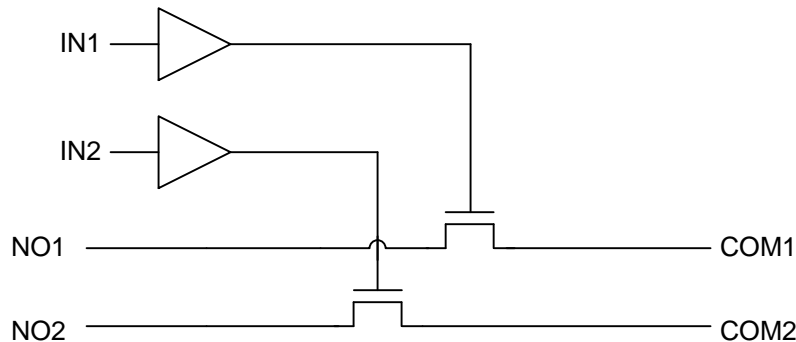

### 8.3 Feature Description

Tolerant control inputs allow 5-V logic levels to be present on the IN pin at any value of  $V_{CC}$ . Low ON-resistance allows minimal signal distortion through device.

### 8.4 Device Functional Modes

[Table 1](#) shows the functional modes for TS5A23166.

**Table 1. Function Table**

IN	NO TO COM, COM TO NO
L	OFF
H	ON

## 9 Application and Implementation

### NOTE

Information in the following applications sections is not part of the TI component specification, and TI does not warrant its accuracy or completeness. TI's customers are responsible for determining suitability of components for their purposes. Customers should validate and test their design implementation to confirm system functionality.

### 9.1 Application Information

The TS5A23166 dual SPST analog switch is a basic component that could be used in any electrical system design. One example application is a gain selector, which is described in the *Typical Application* section.

### 9.2 Typical Application

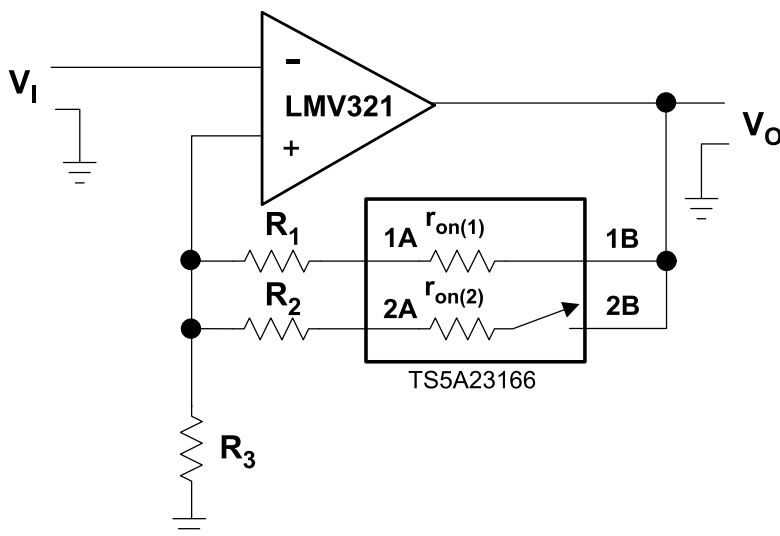

Figure 21. Gain-Control Circuit for OP Amplifier

#### 9.2.1 Design Requirements

By selecting values of  $R_1$  and  $R_2$ , such that  $R_x \gg r_{on(x)}$ ,  $r_{on}$  of TS5A23166 can be ignored. The gain of op amp can be calculated as follow:

$$V_o / V_i = 1 + R_{||} / R_3 \quad (1)$$

$$R_{||} = (R_1 + r_{on(1)}) \parallel (R_2 + r_{on(2)}) \quad (2)$$

#### 9.2.2 Detailed Design Procedure

Place a switch in series with the input of the op amp. Because the op amp input impedance is very large, a switch on  $r_{on(1)}$  is irrelevant.

## Typical Application (continued)

### 9.2.3 Application Curve

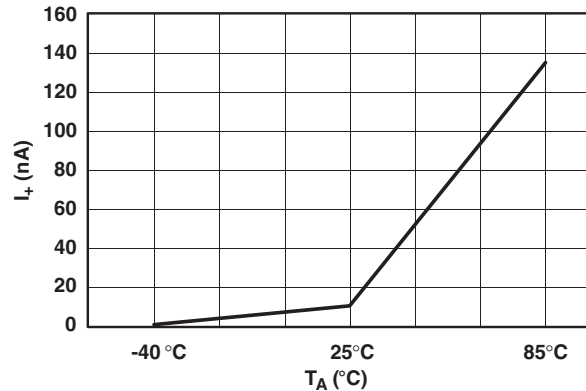

Figure 22. Power-Supply Current vs Temperature (V<sub>+</sub> = 5 V)

## 10 Power Supply Recommendations

The power supply can be any voltage between the minimum and maximum supply voltage rating located in the [Recommended Operating Conditions](#).

Each V<sub>CC</sub> terminal should have a good bypass capacitor to prevent power disturbance. For devices with a single supply, a 0.1-μF bypass capacitor is recommended. If there are multiple pins labeled V<sub>CC</sub>, then a 0.01-μF or 0.022-μF capacitor is recommended for each V<sub>CC</sub> because the VCC pins will be tied together internally. For devices with dual supply pins operating at different voltages, for example V<sub>CC</sub> and V<sub>DD</sub>, a 0.1-μF bypass capacitor is recommended for each supply pin. It is acceptable to parallel multiple bypass capacitors to reject different frequencies of noise. 0.1-μF and 1-μF capacitors are commonly used in parallel. The bypass capacitor should be installed as close to the power terminal as possible for best results.

## 11 Layout

### 11.1 Layout Guidelines

Reflections and matching are closely related to loop antenna theory, but different enough to warrant their own discussion. When a PCB trace turns a corner at a 90° angle, a reflection can occur. This is primarily due to the change of width of the trace. At the apex of the turn, the trace width is increased to 1.414 times its width. This upsets the transmission line characteristics, especially the distributed capacitance and self-inductance of the trace — resulting in the reflection. It is a given that not all PCB traces can be straight, and so they will have to turn corners. [Figure 23](#) shows progressively better techniques of rounding corners. Only the last example maintains constant trace width and minimizes reflections.

### 11.2 Layout Example

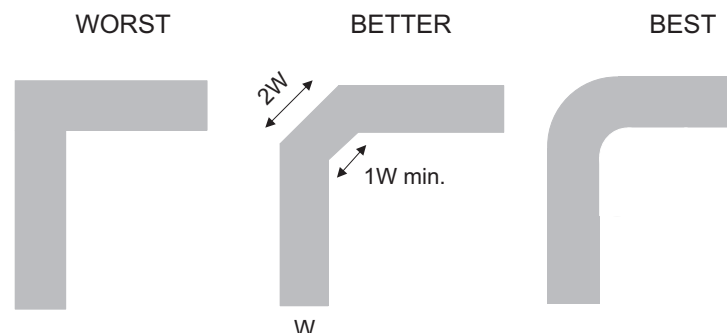

Figure 23. Trace Example

## 12 Device and Documentation Support

### 12.1 Device Support

#### 12.1.1 Device Nomenclature

**Table 2. Parameter Description**

SYMBOL	DESCRIPTION
$V_{COM}$	Voltage at COM
$V_{NO}$	Voltage at NO
$r_{on}$	Resistance between COM and NO ports when the channel is ON
$r_{peak}$	Peak on-state resistance over a specified voltage range
$r_{on(Flat)}$	Difference between the maximum and minimum value of $r_{on}$ in a channel over the specified range of conditions
$I_{NO(OFF)}$	Leakage current measured at the NO port, with the corresponding channel (NO to COM) in the OFF-state under worst-case input and output conditions
$I_{NO(PWROFF)}$	Leakage current measured at the NO port during the power-down condition, $V_+ = 0$
$I_{COM(OFF)}$	Leakage current measured at the COM port, with the corresponding channel (COM to NO) in the OFF-state under worst-case input and output conditions
$I_{COM(PWROFF)}$	Leakage current measured at the COM port during the power-down condition, $V_+ = 0$
$I_{NO(ON)}$	Leakage current measured at the NO port, with the corresponding channel (NO to COM) in the ON-state and the output (COM) open
$I_{COM(ON)}$	Leakage current measured at the COM port, with the corresponding channel (COM to NO) in the ON-state and the output (NO) open
$V_{IH}$	Minimum input voltage for logic high for the control input (IN)
$V_{IL}$	Maximum input voltage for logic low for the control input (IN)
$V_I$	Voltage at the control input (IN)
$I_{IH}, I_{IL}$	Leakage current measured at the control input (IN)
$t_{ON}$	Turnon time for the switch. This parameter is measured under the specified range of conditions and by the propagation delay between the digital control (IN) signal and analog output (COM or NO) signal when the switch is turning ON.
$t_{OFF}$	Turnoff time for the switch. This parameter is measured under the specified range of conditions and by the propagation delay between the digital control (IN) signal and analog output (COM or NO) signal when the switch is turning OFF.
$Q_C$	Charge injection is a measurement of unwanted signal coupling from the control (IN) input to the analog (NO or COM) output. This is measured in coulomb (C) and measured by the total charge induced due to switching of the control input. Charge injection, $Q_C = C_L \times \Delta V_{COM}$ . $C_L$ is the load capacitance, and $\Delta V_{COM}$ is the change in analog output voltage.
$C_{NO(OFF)}$	Capacitance at the NO port when the corresponding channel (NO to COM) is OFF
$C_{COM(OFF)}$	Capacitance at the COM port when the corresponding channel (COM to NO) is OFF
$C_{NO(ON)}$	Capacitance at the NO port when the corresponding channel (NO to COM) is ON
$C_{COM(ON)}$	Capacitance at the COM port when the corresponding channel (COM to NO) is ON
$C_I$	Capacitance of control input (IN)
$O_{ISO}$	OFF isolation of the switch is a measurement of OFF-state switch impedance. This is measured in dB in a specific frequency, with the corresponding channel (NO to COM) in the OFF state.
BW	Bandwidth of the switch. This is the frequency in which the gain of an ON channel is –3 dB below the DC gain.
THD	Total harmonic distortion describes the signal distortion caused by the analog switch. This is defined as the ratio of root mean square (RMS) value of the second, third, and higher harmonic to the absolute magnitude of the fundamental harmonic.
$I_+$	Static power-supply current with the control (IN) pin at $V_+$ or GND

## 12.2 Community Resources

The following links connect to TI community resources. Linked contents are provided "AS IS" by the respective contributors. They do not constitute TI specifications and do not necessarily reflect TI's views; see TI's [Terms of Use](#).

**TI E2E™ Online Community** *TI's Engineer-to-Engineer (E2E) Community*. Created to foster collaboration among engineers. At [e2e.ti.com](http://e2e.ti.com), you can ask questions, share knowledge, explore ideas and help solve problems with fellow engineers.

**Design Support** *TI's Design Support* Quickly find helpful E2E forums along with design support tools and contact information for technical support.

## 12.3 Trademarks

E2E is a trademark of Texas Instruments.  
All other trademarks are the property of their respective owners.

## 12.4 Electrostatic Discharge Caution



These devices have limited built-in ESD protection. The leads should be shorted together or the device placed in conductive foam during storage or handling to prevent electrostatic damage to the MOS gates.

## 12.5 Glossary

[SLYZ022](#) — *TI Glossary*.

This glossary lists and explains terms, acronyms, and definitions.

## 13 Mechanical, Packaging, and Orderable Information

The following pages include mechanical, packaging, and orderable information. This information is the most current data available for the designated devices. This data is subject to change without notice and revision of this document. For browser-based versions of this data sheet, refer to the left-hand navigation.

## PACKAGING INFORMATION

Orderable Device	Status (1)	Package Type	Package Drawing	Pins	Package Qty	Eco Plan (2)	Lead/Ball Finish (6)	MSL Peak Temp (3)	Op Temp (°C)	Device Marking (4/5)	Samples
TS5A23166DCUR	ACTIVE	VSSOP	DCU	8	3000	Green (RoHS & no Sb/Br)	CU NIPDAU   CU SN	Level-1-260C-UNLIM	-40 to 85	(AM ~ JAMQ ~ JAMR) JZ	<a href="#">Samples</a>
TS5A23166DCURG4	ACTIVE	VSSOP	DCU	8	3000	Green (RoHS & no Sb/Br)	CU NIPDAU	Level-1-260C-UNLIM	-40 to 85	JAMR	<a href="#">Samples</a>
TS5A23166YZPR	ACTIVE	DSBGA	YZP	8	3000	Green (RoHS & no Sb/Br)	SNAGCU	Level-1-260C-UNLIM	-40 to 85	(JM7 ~ JMN)	<a href="#">Samples</a>
TS5A23166YZTR	ACTIVE	DSBGA	YZT	8	3000	Green (RoHS & no Sb/Br)	SNAGCU	Level-1-260C-UNLIM	-40 to 85	(JM7 ~ JMN)	<a href="#">Samples</a>

(1) The marketing status values are defined as follows:

**ACTIVE:** Product device recommended for new designs.

**LIFEBUY:** TI has announced that the device will be discontinued, and a lifetime-buy period is in effect.

**NRND:** Not recommended for new designs. Device is in production to support existing customers, but TI does not recommend using this part in a new design.

**PREVIEW:** Device has been announced but is not in production. Samples may or may not be available.

**OBSOLETE:** TI has discontinued the production of the device.

(2) Eco Plan - The planned eco-friendly classification: Pb-Free (RoHS), Pb-Free (RoHS Exempt), or Green (RoHS & no Sb/Br) - please check <http://www.ti.com/productcontent> for the latest availability information and additional product content details.

**TBD:** The Pb-Free/Green conversion plan has not been defined.

**Pb-Free (RoHS):** TI's terms "Lead-Free" or "Pb-Free" mean semiconductor products that are compatible with the current RoHS requirements for all 6 substances, including the requirement that lead not exceed 0.1% by weight in homogeneous materials. Where designed to be soldered at high temperatures, TI Pb-Free products are suitable for use in specified lead-free processes.

**Pb-Free (RoHS Exempt):** This component has a RoHS exemption for either 1) lead-based flip-chip solder bumps used between the die and package, or 2) lead-based die adhesive used between the die and leadframe. The component is otherwise considered Pb-Free (RoHS compatible) as defined above.

**Green (RoHS & no Sb/Br):** TI defines "Green" to mean Pb-Free (RoHS compatible), and free of Bromine (Br) and Antimony (Sb) based flame retardants (Br or Sb do not exceed 0.1% by weight in homogeneous material)

(3) MSL, Peak Temp. - The Moisture Sensitivity Level rating according to the JEDEC industry standard classifications, and peak solder temperature.

(4) There may be additional marking, which relates to the logo, the lot trace code information, or the environmental category on the device.

(5) Multiple Device Markings will be inside parentheses. Only one Device Marking contained in parentheses and separated by a "~" will appear on a device. If a line is indented then it is a continuation of the previous line and the two combined represent the entire Device Marking for that device.

(6) Lead/Ball Finish - Orderable Devices may have multiple material finish options. Finish options are separated by a vertical ruled line. Lead/Ball Finish values may wrap to two lines if the finish value exceeds the maximum column width.

**Important Information and Disclaimer:** The information provided on this page represents TI's knowledge and belief as of the date that it is provided. TI bases its knowledge and belief on information provided by third parties, and makes no representation or warranty as to the accuracy of such information. Efforts are underway to better integrate information from third parties. TI has taken and continues to take reasonable steps to provide representative and accurate information but may not have conducted destructive testing or chemical analysis on incoming materials and chemicals. TI and TI suppliers consider certain information to be proprietary, and thus CAS numbers and other limited information may not be available for release.

In no event shall TI's liability arising out of such information exceed the total purchase price of the TI part(s) at issue in this document sold by TI to Customer on an annual basis.



## TAPE AND REEL INFORMATION



### QUADRANT ASSIGNMENTS FOR PIN 1 ORIENTATION IN TAPE



\*All dimensions are nominal

Device	Package Type	Package Drawing	Pins	SPQ	Reel Diameter (mm)	Reel Width W1 (mm)	A0 (mm)	B0 (mm)	K0 (mm)	P1 (mm)	W (mm)	Pin1 Quadrant
TS5A23166DCUR	VSSOP	DCU	8	3000	178.0	9.5	2.25	3.35	1.05	4.0	8.0	Q3
TS5A23166DCUR	VSSOP	DCU	8	3000	180.0	9.0	2.05	3.3	1.0	4.0	8.0	Q3
TS5A23166DCURG4	VSSOP	DCU	8	3000	180.0	8.4	2.25	3.35	1.05	4.0	8.0	Q3
TS5A23166YZPR	DSBGA	YZP	8	3000	178.0	9.2	1.02	2.02	0.63	4.0	8.0	Q1
TS5A23166YZTR	DSBGA	YZT	8	3000	178.0	9.2	1.02	2.02	0.75	4.0	8.0	Q1

**TAPE AND REEL BOX DIMENSIONS**

\*All dimensions are nominal

Device	Package Type	Package Drawing	Pins	SPQ	Length (mm)	Width (mm)	Height (mm)
TS5A23166DCUR	VSSOP	DCU	8	3000	202.0	201.0	28.0
TS5A23166DCUR	VSSOP	DCU	8	3000	182.0	182.0	20.0
TS5A23166DCURG4	VSSOP	DCU	8	3000	202.0	201.0	28.0
TS5A23166YZPR	DSBGA	YZP	8	3000	220.0	220.0	35.0
TS5A23166YZTR	DSBGA	YZT	8	3000	220.0	220.0	35.0

YZP0008

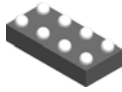

# PACKAGE OUTLINE

DSBGA - 0.5 mm max height

DIE SIZE BALL GRID ARRAY



NOTES:

1. All linear dimensions are in millimeters. Any dimensions in parenthesis are for reference only. Dimensioning and tolerancing per ASME Y14.5M.
2. This drawing is subject to change without notice.

# EXAMPLE BOARD LAYOUT

YZP0008

DSBGA - 0.5 mm max height

DIE SIZE BALL GRID ARRAY



LAND PATTERN EXAMPLE  
SCALE:40X



SOLDER MASK DETAILS  
NOT TO SCALE

4223082/A 07/2016

NOTES: (continued)

3. Final dimensions may vary due to manufacturing tolerance considerations and also routing constraints. For more information, see Texas Instruments literature number SNVA009 ([www.ti.com/lit/snva009](http://www.ti.com/lit/snva009)).

# EXAMPLE STENCIL DESIGN

YZP0008

DSBGA - 0.5 mm max height

DIE SIZE BALL GRID ARRAY



SOLDER PASTE EXAMPLE  
BASED ON 0.1 mm THICK STENCIL  
SCALE:40X

4223082/A 07/2016

NOTES: (continued)

4. Laser cutting apertures with trapezoidal walls and rounded corners may offer better paste release.

# MECHANICAL DATA

DCU (R-PDSO-G8)

PLASTIC SMALL-OUTLINE PACKAGE (DIE DOWN)

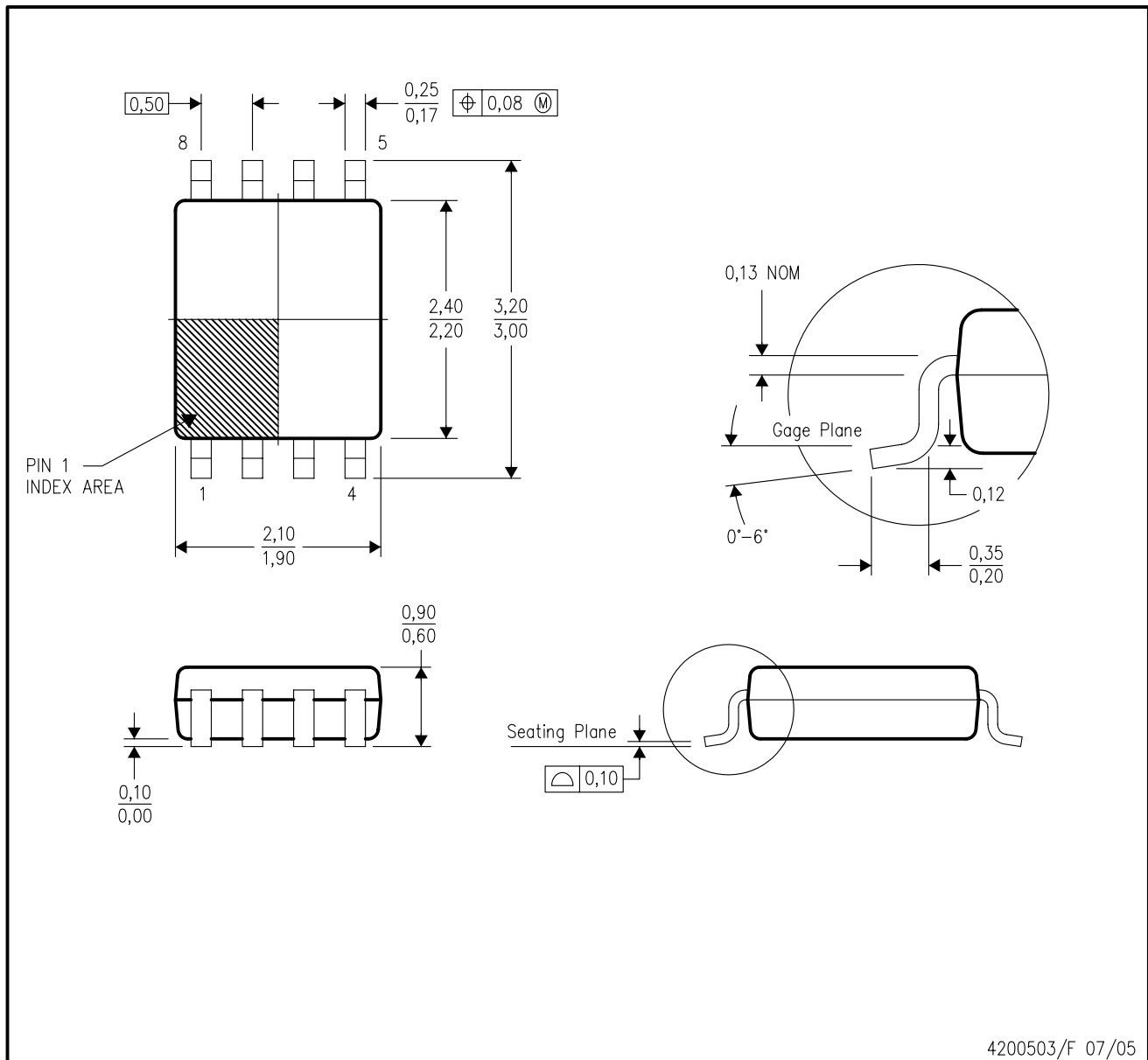

- NOTES:
- A. All linear dimensions are in millimeters.
  - B. This drawing is subject to change without notice.
  - C. Body dimensions do not include mold flash or protrusion. Mold flash and protrusion shall not exceed 0.15 per side.
  - D. Falls within JEDEC MO-187 variation CA.

DCU (S-PDSO-G8)

PLASTIC SMALL OUTLINE PACKAGE (DIE DOWN)



4210064/C 04/12

- NOTES:
- A. All linear dimensions are in millimeters.
  - B. This drawing is subject to change without notice.
  - C. Publication IPC-7351 is recommended for alternate designs.
  - D. Laser cutting apertures with trapezoidal walls and also rounding corners will offer better paste release. Customers should contact their board assembly site for stencil design recommendations. Refer to IPC-7525 for other stencil recommendations.
  - E. Customers should contact their board fabrication site for solder mask tolerances between and around signal pads.

# MECHANICAL DATA

YZT (R-XBGA-N8)

DIE-SIZE BALL GRID ARRAY

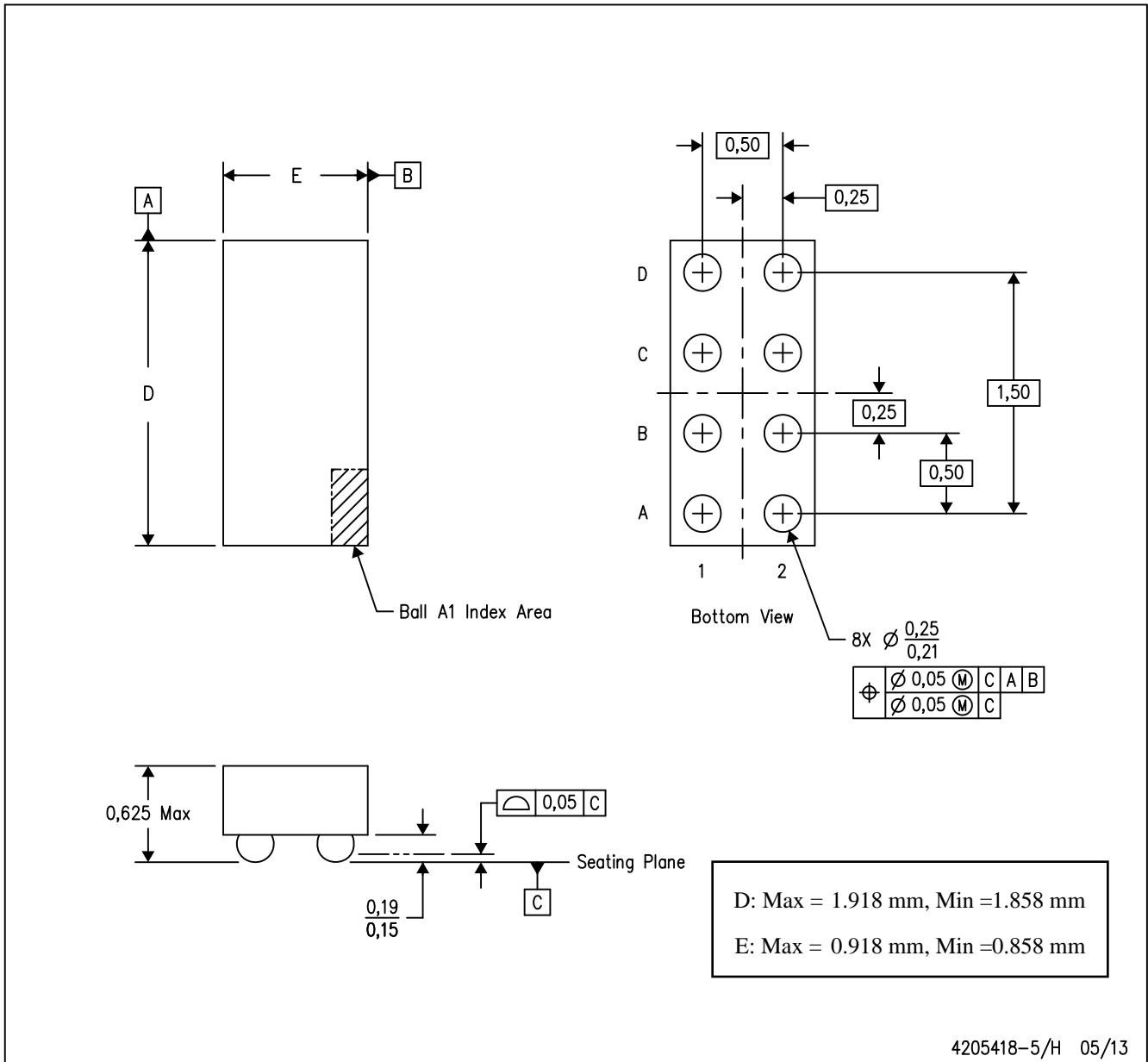

- NOTES:
- A. All linear dimensions are in millimeters. Dimensioning and tolerancing per ASME Y14.5M-1994.
  - B. This drawing is subject to change without notice.
  - C. NanoFree™ package configuration.

NanoFree is a trademark of Texas Instruments.



## IMPORTANT NOTICE

Texas Instruments Incorporated (TI) reserves the right to make corrections, enhancements, improvements and other changes to its semiconductor products and services per JESD46, latest issue, and to discontinue any product or service per JESD48, latest issue. Buyers should obtain the latest relevant information before placing orders and should verify that such information is current and complete.

TI's published terms of sale for semiconductor products (<http://www.ti.com/sc/docs/stdterms.htm>) apply to the sale of packaged integrated circuit products that TI has qualified and released to market. Additional terms may apply to the use or sale of other types of TI products and services.

Reproduction of significant portions of TI information in TI data sheets is permissible only if reproduction is without alteration and is accompanied by all associated warranties, conditions, limitations, and notices. TI is not responsible or liable for such reproduced documentation. Information of third parties may be subject to additional restrictions. Resale of TI products or services with statements different from or beyond the parameters stated by TI for that product or service voids all express and any implied warranties for the associated TI product or service and is an unfair and deceptive business practice. TI is not responsible or liable for any such statements.

Buyers and others who are developing systems that incorporate TI products (collectively, "Designers") understand and agree that Designers remain responsible for using their independent analysis, evaluation and judgment in designing their applications and that Designers have full and exclusive responsibility to assure the safety of Designers' applications and compliance of their applications (and of all TI products used in or for Designers' applications) with all applicable regulations, laws and other applicable requirements. Designer represents that, with respect to their applications, Designer has all the necessary expertise to create and implement safeguards that (1) anticipate dangerous consequences of failures, (2) monitor failures and their consequences, and (3) lessen the likelihood of failures that might cause harm and take appropriate actions. Designer agrees that prior to using or distributing any applications that include TI products, Designer will thoroughly test such applications and the functionality of such TI products as used in such applications.

TI's provision of technical, application or other design advice, quality characterization, reliability data or other services or information, including, but not limited to, reference designs and materials relating to evaluation modules, (collectively, "TI Resources") are intended to assist designers who are developing applications that incorporate TI products; by downloading, accessing or using TI Resources in any way, Designer (individually or, if Designer is acting on behalf of a company, Designer's company) agrees to use any particular TI Resource solely for this purpose and subject to the terms of this Notice.

TI's provision of TI Resources does not expand or otherwise alter TI's applicable published warranties or warranty disclaimers for TI products, and no additional obligations or liabilities arise from TI providing such TI Resources. TI reserves the right to make corrections, enhancements, improvements and other changes to its TI Resources. TI has not conducted any testing other than that specifically described in the published documentation for a particular TI Resource.

Designer is authorized to use, copy and modify any individual TI Resource only in connection with the development of applications that include the TI product(s) identified in such TI Resource. NO OTHER LICENSE, EXPRESS OR IMPLIED, BY ESTOPPEL OR OTHERWISE TO ANY OTHER TI INTELLECTUAL PROPERTY RIGHT, AND NO LICENSE TO ANY TECHNOLOGY OR INTELLECTUAL PROPERTY RIGHT OF TI OR ANY THIRD PARTY IS GRANTED HEREIN, including but not limited to any patent right, copyright, mask work right, or other intellectual property right relating to any combination, machine, or process in which TI products or services are used. Information regarding or referencing third-party products or services does not constitute a license to use such products or services, or a warranty or endorsement thereof. Use of TI Resources may require a license from a third party under the patents or other intellectual property of the third party, or a license from TI under the patents or other intellectual property of TI.

TI RESOURCES ARE PROVIDED "AS IS" AND WITH ALL FAULTS. TI DISCLAIMS ALL OTHER WARRANTIES OR REPRESENTATIONS, EXPRESS OR IMPLIED, REGARDING RESOURCES OR USE THEREOF, INCLUDING BUT NOT LIMITED TO ACCURACY OR COMPLETENESS, TITLE, ANY EPIDEMIC FAILURE WARRANTY AND ANY IMPLIED WARRANTIES OF MERCHANTABILITY, FITNESS FOR A PARTICULAR PURPOSE, AND NON-INFRINGEMENT OF ANY THIRD PARTY INTELLECTUAL PROPERTY RIGHTS. TI SHALL NOT BE LIABLE FOR AND SHALL NOT DEFEND OR INDEMNIFY DESIGNER AGAINST ANY CLAIM, INCLUDING BUT NOT LIMITED TO ANY INFRINGEMENT CLAIM THAT RELATES TO OR IS BASED ON ANY COMBINATION OF PRODUCTS EVEN IF DESCRIBED IN TI RESOURCES OR OTHERWISE. IN NO EVENT SHALL TI BE LIABLE FOR ANY ACTUAL, DIRECT, SPECIAL, COLLATERAL, INDIRECT, PUNITIVE, INCIDENTAL, CONSEQUENTIAL OR EXEMPLARY DAMAGES IN CONNECTION WITH OR ARISING OUT OF TI RESOURCES OR USE THEREOF, AND REGARDLESS OF WHETHER TI HAS BEEN ADVISED OF THE POSSIBILITY OF SUCH DAMAGES.

Unless TI has explicitly designated an individual product as meeting the requirements of a particular industry standard (e.g., ISO/TS 16949 and ISO 26262), TI is not responsible for any failure to meet such industry standard requirements.

Where TI specifically promotes products as facilitating functional safety or as compliant with industry functional safety standards, such products are intended to help enable customers to design and create their own applications that meet applicable functional safety standards and requirements. Using products in an application does not by itself establish any safety features in the application. Designers must ensure compliance with safety-related requirements and standards applicable to their applications. Designer may not use any TI products in life-critical medical equipment unless authorized officers of the parties have executed a special contract specifically governing such use. Life-critical medical equipment is medical equipment where failure of such equipment would cause serious bodily injury or death (e.g., life support, pacemakers, defibrillators, heart pumps, neurostimulators, and implantables). Such equipment includes, without limitation, all medical devices identified by the U.S. Food and Drug Administration as Class III devices and equivalent classifications outside the U.S.

TI may expressly designate certain products as completing a particular qualification (e.g., Q100, Military Grade, or Enhanced Product). Designers agree that it has the necessary expertise to select the product with the appropriate qualification designation for their applications and that proper product selection is at Designers' own risk. Designers are solely responsible for compliance with all legal and regulatory requirements in connection with such selection.

Designer will fully indemnify TI and its representatives against any damages, costs, losses, and/or liabilities arising out of Designer's non-compliance with the terms and provisions of this Notice.