

# High Power Factor Preregulator

## FEATURES

- Complete 8-pin Power Factor Solution
- Reduced External Components
- RMS Line Voltage Compensation
- Precision Multiplier/Squarer/Divider
- Internal 63kHz Synchronizable Oscillator
- Average Current Mode PWM Control
- Overvoltage Protection Comparator
- High Current, Clamped Gate Driver

## DESCRIPTION

The UC2853A provides simple, yet high performance active power factor correction. Using the same control technique as the UC1854, this 8-pin device exploits a simplified architecture and an internal oscillator to minimize external component count. The UC2853A incorporates a precision multiplier/squarer/divider circuit, voltage and current loop error amplifiers, and a precision voltage reference to implement average current mode control with RMS line voltage compensation. This control technique maintains constant loop gain with changes in input voltage, which minimizes input line current distortion over the worldwide input voltage range.

The internal 63kHz oscillator includes an external clock input, allowing synchronization to downstream converters. Additionally, the device features an overvoltage protection comparator, a clamped MOSFET gate driver which self-biases low during undervoltage lockout, and low startup and supply current.

The UC2853A is identical to the UC2853 except the internal oscillator frequency has been reduced from 75kHz to 63kHz. The switching frequency is lowered in order to keep the second harmonic of the switching frequency below a 150kHz. For EMI specifications at 150kHz this makes it easier for a design to meet system requirements.

## BLOCK DIAGRAM

These devices are available in 8-pin PDIP (P) and SOIC (D) packages. The UC2853A is specified for operation from  $-40^{\circ}\text{C}$  to  $105^{\circ}\text{C}$ .

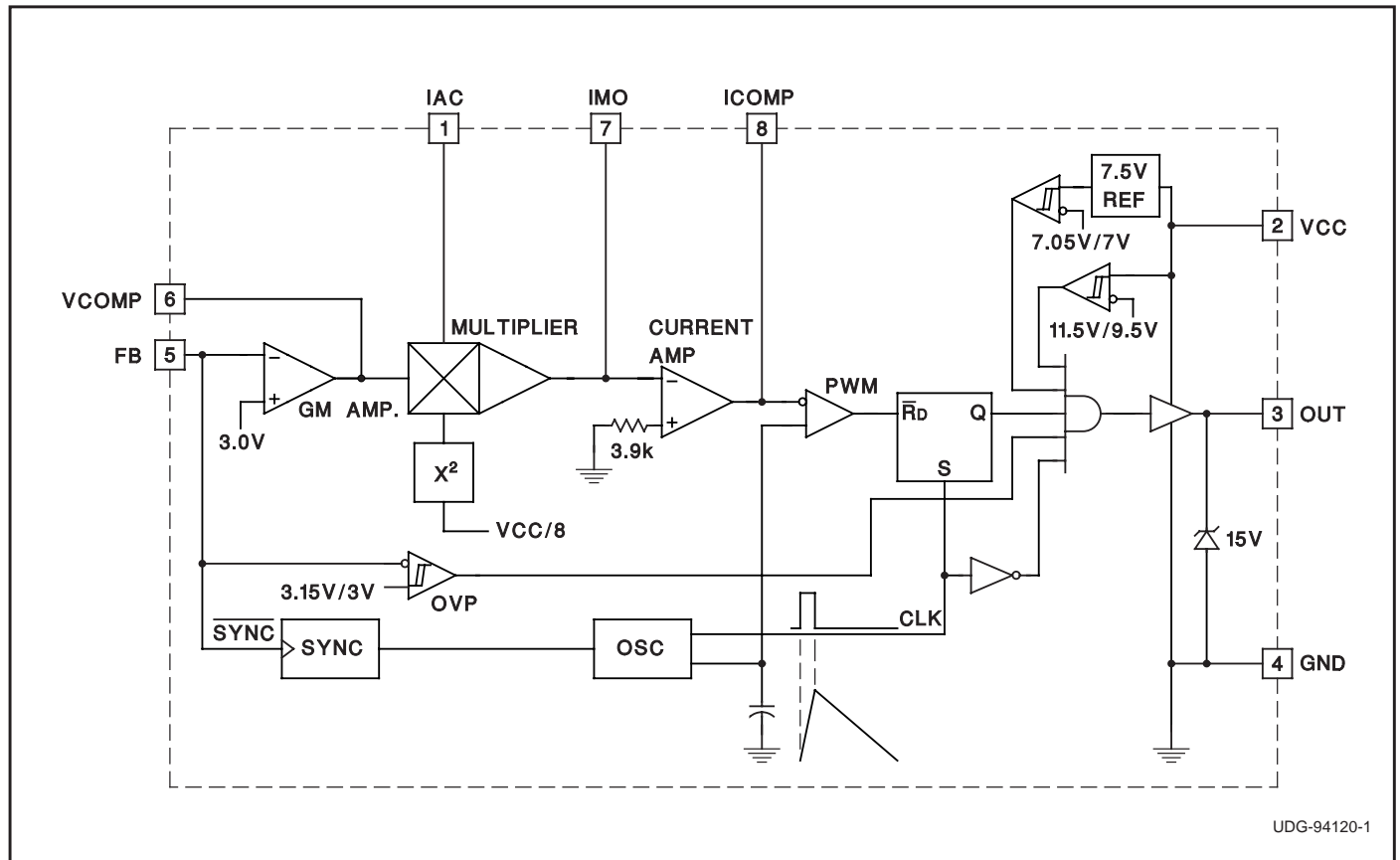

**ABSOLUTE MAXIMUM RATINGS**

Supply Voltage (VCC) . . . . .	40V
Output Drive Current,	
Continuous . . . . .	0.125A
Peak . . . . .	0.5A
Output Minimum Voltage . . . . .	-0.3V
IAC Maximum Input Current . . . . .	1mA
IMO Maximum Output Current . . . . .	-2mA
IMO Minimum Voltage . . . . .	-0.3V
FB Maximum Input Voltage . . . . .	5V
VCOMP Maximum Voltage . . . . .	6.2V
ICOMP Sourcing Current . . . . .	Self-Limiting
ICOMP Sinking Current . . . . .	20mA
ICOMP Maximum Voltage . . . . .	7.2V
Storage Temperature . . . . .	-65°C to +150°C
Junction Temperature . . . . .	-55°C to +150°C
Lead Temperature (Soldering, 10 sec.) . . . . .	+300°C

All voltages with respect to GND. Currents are positive into, negative out of the specified terminal. Consult Packaging Section of Databook for thermal limitations and considerations of packages.

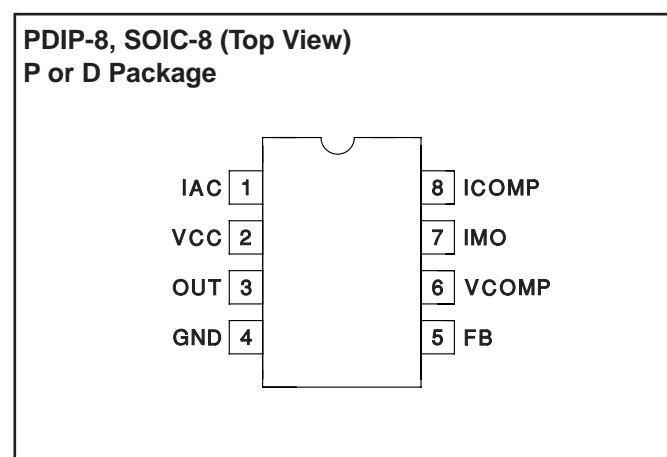
**CONNECTION DIAGRAM****ELECTRICAL CHARACTERISTICS**

Unless otherwise stated, these parameters apply for  $T_A = -40^\circ\text{C}$  to  $105^\circ\text{C}$  for the UC2853A;  $V_{CC} = 16\text{V}$ ,  $V_{FB} = 3\text{V}$ ,  $I_{AC} = 100\mu\text{A}$ ,  $V_{VCOMP} = 3.75\text{V}$ ,  $V_{ICOMP} = 3\text{V}$ ,  $T_A = T_J$ .

PARAMETER	TEST CONDITIONS	MIN	TYP	MAX	UNITS
<b>Undervoltage Lockout Section</b>					
VCC Turn-on Threshold	$V_{VCOMP}$ , $V_{ICOMP}$ Open		11.5	13	V
Hysteresis		1.5	1.8	2.1	V
<b>Supply Current Section</b>					
$I_{VCC}$ Startup	$V_{CC} = 8\text{V}$ , $I_{AC} = 100\mu\text{A}$ ; $V_{VCOMP}$ , $V_{ICOMP}$ Open		250	500	$\mu\text{A}$
$I_{VCC}$	$I_{AC} = 0\mu\text{A}$ , $V_{ICOMP} = 0\text{V}$		10	15	$\text{mA}$
<b>Voltage Loop Error Amplifier Section</b>					
Transconductance	$I_{OUT} = \pm 20\mu\text{A}$ 0-70C	300	450	575	$\mu\text{mho}$
	Temperature	135		640	$\mu\text{mho}$
Input Voltage	0-70C	2.925	3	3.075	V
	Temperature	2.9		3.1	V
AVOL	$V_{VCOMP} = 1\text{V} - 4\text{V}$	50	60		dB
Output Sink Current	$V_{FB} = 3.2\text{V}$ , $V_{VCOMP} = 3.75\text{V}$	20	50		$\mu\text{A}$
Output Source Current	$V_{FB} = 2.8\text{V}$ , $V_{VCOMP} = 3.75\text{V}$		-50	-20	$\mu\text{A}$
Output Voltage High		5.5	6		V
Output Voltage Low			0.6	0.9	V
<b>Current Loop Error Amplifier Section</b>					
Offset Voltage		0		6	mV
Voltage Gain	$V_{ICOMP} = 1\text{V} - 4\text{V}$		70		dB
Sink Current	$V_{IMO} = 100\text{mV}$ , $V_{ICOMP} = 3\text{V}$	1			$\text{mA}$
Source Current	$V_{IMO} = -0.1\text{V}$ , $V_{ICOMP} = 3\text{V}$		-150	-80	$\mu\text{A}$
Output High	$I_{ICOMP} = -50\text{mA}$	6	6.8		V
Output Low	$I_{ICOMP} = 50\mu\text{A}$		0.3	0.8	V
PWM Modulator Gain	$V_{ICOMP} = 2\text{V} - 3\text{V}$ (Note 1)		20		%/V

**ELECTRICAL CHARACTERISTICS**  
**(continued)**

Unless otherwise stated, these parameters apply for  $T_A = -40^{\circ}\text{C}$  to  $105^{\circ}\text{C}$  for the UC2853A;  $V_{CC} = 16\text{V}$ ,  $V_{FB} = 3\text{V}$ ,  $I_{AC} = 100\mu\text{A}$ ,  $V_{VCOMP} = 3.75\text{V}$ ,  $V_{ICOMP} = 3\text{V}$ ,  $T_A = T_J$ .

PARAMETER	TEST CONDITIONS	MIN	TYP	MAX	UNITS
<b>Multiplier Section</b>					
Output Current – IAC Limited	$V_{CC} = 11\text{V}$ , $V_{VCOMP} = 6\text{V}$	-230	-200	-170	$\mu\text{A}$
Output Current – Zero	$I_{AC} = 0\mu\text{A}$	-2	-0.2	2	$\mu\text{A}$
Output Current – Power Limited	$V_{CC} = 12\text{V}$ , $V_{VCOMP} = 5.5\text{V}$	-236	-178	-168	$\mu\text{A}$
Output Current	$V_{CC} = 12\text{V}$ , $V_{VCOMP} = 2\text{V}$		-22		$\mu\text{A}$
	$V_{CC} = 12\text{V}$ , $V_{VCOMP} = 5\text{V}$		-156		$\mu\text{A}$
	$V_{CC} = 40\text{V}$ , $V_{VCOMP} = 2\text{V}$		-2		$\mu\text{A}$
	$V_{CC} = 40\text{V}$ , $V_{VCOMP} = 5\text{V}$		-14		$\mu\text{A}$
Multiplier Gain Constant	$V_{CC} = 12\text{V}$ , $V_{VCOMP} = 5.5\text{V}$ (Note 2)	-1.05	-0.9	-0.75	$\text{V}^{-1}$
<b>Oscillator Section</b>					
Oscillator Initial Frequency	$T_A = 25^{\circ}\text{C}$	56	63	70	kHz
Oscillator Frequency	Line, Load, Temperature	50	63	74	kHz
Synchronization Frequency Range				100	kHz
Synchronization Pulse Amplitude	Pulse slew rate = $100\text{V}/\mu\text{sec}$ (Note 3)		2		V
<b>Output Driver Section</b>					
Maximum Output Voltage	0mA load, $V_{CC} = 20\text{V}$	12	15	17.5	V
Output High	0mA load, $V_{CC} = 12\text{V}$ , ref. to VCC	-2.7	-1.7		V
	-50mA load, $V_{CC} = 12\text{V}$ , ref. to VCC	-3	-2.2		V
Output Low (Device Inactive)	$V_{CC} = 0\text{V}$ , 20mA load (Sinking)		0.9	2.0	V
Output Low (Device Active)	50mA load (Sinking)		0.5	1	V
OUT Rise Time	1nF from OUT to GND		55	100	ns
OUT Fall Time	1nF from OUT to GND		35	100	ns
OUT Maximum Duty Cycle	$V_{ICOMP} = 0\text{V}$	88	93		%
<b>OVP Comparator Section</b>					
Threshold Voltage	Volts Above EA Input V	90	150		mV
Hysteresis			80		mV

Note 1:

$$1\text{PWM modulator gain} = \frac{\Delta\text{DutyCycle}}{\Delta V_{ICOMP}}$$

Note 2:

$$\text{Gain constant (K)} = \frac{I_{AC} \cdot (V_{COMP} - 1.5\text{V})}{I_{MO} \cdot V_{CC} \cdot \frac{V_{CC}}{64}}, \text{VCC} = 12\text{V}.$$

Note 3.

Synchronization is accomplished with a falling edge of 2V magnitude and  $100\text{V}/\mu\text{sec}$  slew rate.

UC2853A TYPICAL APPLICATION

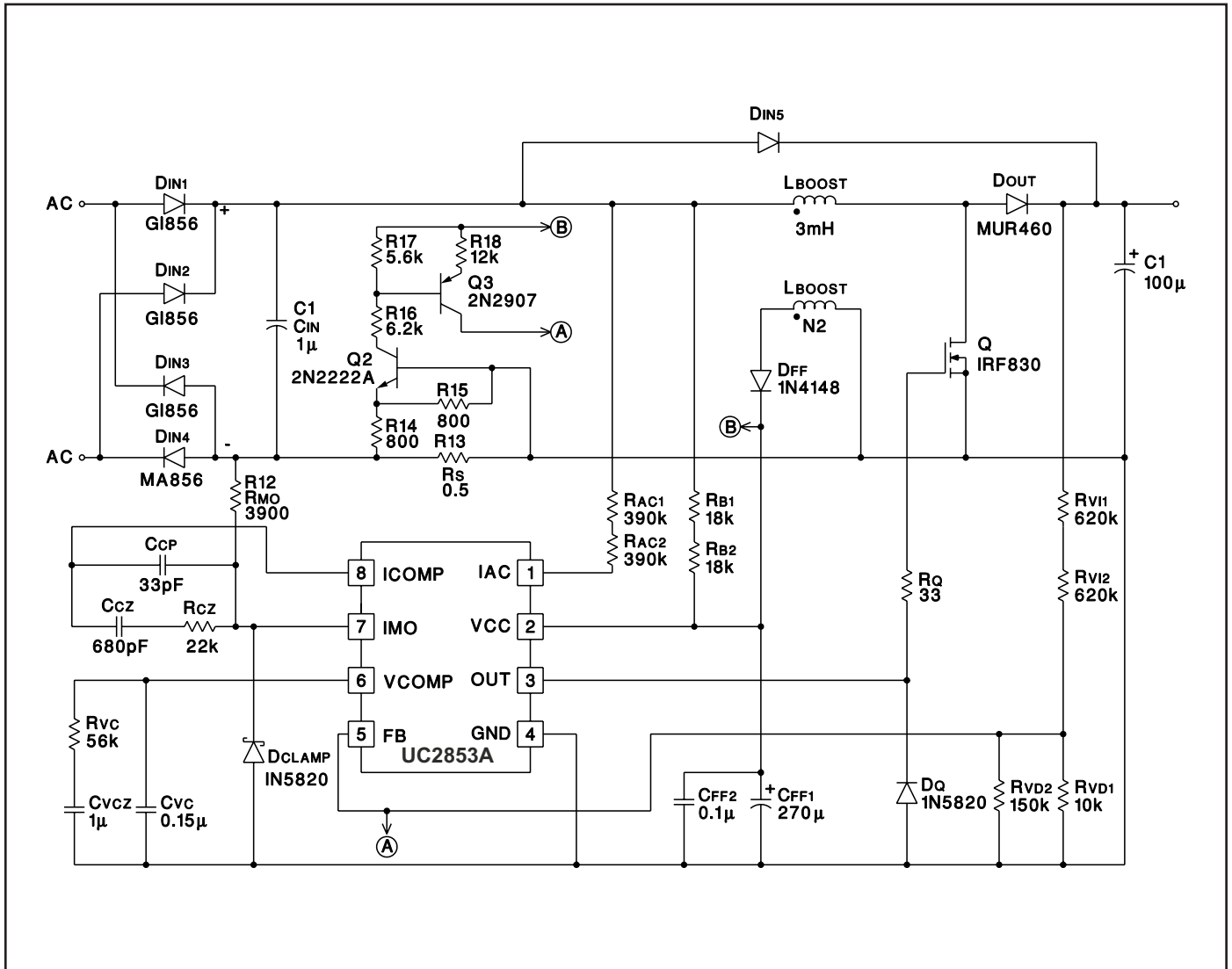

Note: the application circuit shown is a 100W, 63KHz design. Additional application information can be found in Application Note U-159 (TI literature Number SLUA080) and Design Note DN-78.

## PIN DESCRIPTIONS

**FB:** Voltage Amplifier Inverting Input, Overvoltage Comparator Input, Sync Input. This pin serves three functions. FB accepts a fraction of the power factor corrected output voltage through a voltage divider, and is nominally regulated to 3V. FB voltages 5% greater than nominal will trip the overvoltage comparator, and shut down the output stage until the output voltage drops 5%. The internal oscillator can be synchronized through FB by injecting a 2V clock signal through a capacitor. To prevent false tripping of the overvoltage comparator, the clock signal must have a fast falling edge, but a slow rising edge. See Application Note U-159 for more information.

**GND:** Ground. All voltages are measured with respect to GND. The VCC bypass capacitor should be connected to ground as close to the GND pin as possible.

**IAC:** AC Waveform Input. This input provides voltage waveform information to the multiplier. The current loop will try to produce a current waveform with the same shape as the IAC signal. IAC is a low impedance input, nominally at 2V, which accepts a current proportional to the input voltage. Connect a resistor from the rectified input line to IAC which will conduct 500 $\mu$ A at maximum line voltage.

**IMO:** Multiplier Output and Current Sense Inverting Input. The output of the multiplier and the inverting input of the current amplifier are connected together at IMO. Avoid bringing this input below  $-0.5V$  to prevent the internal protection diode from conducting. The multiplier output is a current, making this a summing node and allowing a differential current error amplifier configuration to reject ground noise. The input resistance at this node should be 3.9k to minimize input bias current induced offset voltage. See the Applications section for the recommended circuit configuration.

**OUT:** Gate Driver Output. OUT provides high current gate drive for the external power MOSFET. A 15V clamp pre-

vents excessive MOSFET gate-to-source voltage so that the UC2853A can be operated with VCC and high as 40V. A series gate resistor of at least 5 ohms should be used to minimize clamp voltage overshoot. In addition, a Schottky diode such as a 1N5818 connected between OUT and GND may be necessary to prevent parasitic substrate diode conduction.

**ICOMP:** Current Loop Error Amplifier Output. The current loop error amplifier is a conventional operational amplifier with a 150 $\mu$ A current source class A output stage. Compensate the current loop by placing an impedance between ICOMP and IMO. This output can swing above the oscillator peak voltage, allowing zero duty cycle when necessary.

**VCC:** Input Supply Voltage. This pin serves two functions. It supplies power to the chip, and an input voltage level signal to the squarer circuit. When this input is connected to a DC voltage proportional to the AC input RMS voltage, the voltage loop gain is reduced by

$$\frac{64}{V_{CC}^2}$$

This configuration maintains constant loop gain. The UC2853A input voltage range extends from 12V to 40V, allowing an AC supply voltage range in excess of 85VAC to 265VAC. Bypass VCC with at least a 0.1 $\mu$ F ceramic capacitor to ensure proper operation. See the Applications section for the recommended circuit configuration.

**VCOMP:** Voltage Loop Error Amplifier Output. The voltage loop error amplifier is a transconductance type operational amplifier. A feedback impedance between VCOMP and FB for loop compensation must be avoided to maintain proper operation of the overvoltage protection comparator. Instead, compensate the voltage loop with an impedance between VCOMP and GND. When VCOMP is below 1.5V, the multiplier output current is zero.

## TAPE AND REEL INFORMATION



### QUADRANT ASSIGNMENTS FOR PIN 1 ORIENTATION IN TAPE



\*All dimensions are nominal

Device	Package Type	Package Drawing	Pins	SPQ	Reel Diameter (mm)	Reel Width W1 (mm)	A0 (mm)	B0 (mm)	K0 (mm)	P1 (mm)	W (mm)	Pin1 Quadrant
UC2853ADTR	SOIC	D	8	2500	330.0	12.4	6.4	5.2	2.1	8.0	12.0	Q1

**TAPE AND REEL BOX DIMENSIONS**





\*All dimensions are nominal

Device	Package Type	Package Drawing	Pins	SPQ	Length (mm)	Width (mm)	Height (mm)
UC2853ADTR	SOIC	D	8	2500	367.0	367.0	35.0

D (R-PDSO-G8)

PLASTIC SMALL OUTLINE



- NOTES:
- A. All linear dimensions are in inches (millimeters).
  - B. This drawing is subject to change without notice.
  -  Body length does not include mold flash, protrusions, or gate burrs. Mold flash, protrusions, or gate burrs shall not exceed 0.006 (0,15) each side.
  -  Body width does not include interlead flash. Interlead flash shall not exceed 0.017 (0,43) each side.
  - E. Reference JEDEC MS-012 variation AA.



## IMPORTANT NOTICE

Texas Instruments Incorporated (TI) reserves the right to make corrections, enhancements, improvements and other changes to its semiconductor products and services per JESD46, latest issue, and to discontinue any product or service per JESD48, latest issue. Buyers should obtain the latest relevant information before placing orders and should verify that such information is current and complete.

TI's published terms of sale for semiconductor products (<http://www.ti.com/sc/docs/stdterms.htm>) apply to the sale of packaged integrated circuit products that TI has qualified and released to market. Additional terms may apply to the use or sale of other types of TI products and services.

Reproduction of significant portions of TI information in TI data sheets is permissible only if reproduction is without alteration and is accompanied by all associated warranties, conditions, limitations, and notices. TI is not responsible or liable for such reproduced documentation. Information of third parties may be subject to additional restrictions. Resale of TI products or services with statements different from or beyond the parameters stated by TI for that product or service voids all express and any implied warranties for the associated TI product or service and is an unfair and deceptive business practice. TI is not responsible or liable for any such statements.

Buyers and others who are developing systems that incorporate TI products (collectively, "Designers") understand and agree that Designers remain responsible for using their independent analysis, evaluation and judgment in designing their applications and that Designers have full and exclusive responsibility to assure the safety of Designers' applications and compliance of their applications (and of all TI products used in or for Designers' applications) with all applicable regulations, laws and other applicable requirements. Designer represents that, with respect to their applications, Designer has all the necessary expertise to create and implement safeguards that (1) anticipate dangerous consequences of failures, (2) monitor failures and their consequences, and (3) lessen the likelihood of failures that might cause harm and take appropriate actions. Designer agrees that prior to using or distributing any applications that include TI products, Designer will thoroughly test such applications and the functionality of such TI products as used in such applications.

TI's provision of technical, application or other design advice, quality characterization, reliability data or other services or information, including, but not limited to, reference designs and materials relating to evaluation modules, (collectively, "TI Resources") are intended to assist designers who are developing applications that incorporate TI products; by downloading, accessing or using TI Resources in any way, Designer (individually or, if Designer is acting on behalf of a company, Designer's company) agrees to use any particular TI Resource solely for this purpose and subject to the terms of this Notice.

TI's provision of TI Resources does not expand or otherwise alter TI's applicable published warranties or warranty disclaimers for TI products, and no additional obligations or liabilities arise from TI providing such TI Resources. TI reserves the right to make corrections, enhancements, improvements and other changes to its TI Resources. TI has not conducted any testing other than that specifically described in the published documentation for a particular TI Resource.

Designer is authorized to use, copy and modify any individual TI Resource only in connection with the development of applications that include the TI product(s) identified in such TI Resource. NO OTHER LICENSE, EXPRESS OR IMPLIED, BY ESTOPPEL OR OTHERWISE TO ANY OTHER TI INTELLECTUAL PROPERTY RIGHT, AND NO LICENSE TO ANY TECHNOLOGY OR INTELLECTUAL PROPERTY RIGHT OF TI OR ANY THIRD PARTY IS GRANTED HEREIN, including but not limited to any patent right, copyright, mask work right, or other intellectual property right relating to any combination, machine, or process in which TI products or services are used. Information regarding or referencing third-party products or services does not constitute a license to use such products or services, or a warranty or endorsement thereof. Use of TI Resources may require a license from a third party under the patents or other intellectual property of the third party, or a license from TI under the patents or other intellectual property of TI.

TI RESOURCES ARE PROVIDED "AS IS" AND WITH ALL FAULTS. TI DISCLAIMS ALL OTHER WARRANTIES OR REPRESENTATIONS, EXPRESS OR IMPLIED, REGARDING RESOURCES OR USE THEREOF, INCLUDING BUT NOT LIMITED TO ACCURACY OR COMPLETENESS, TITLE, ANY EPIDEMIC FAILURE WARRANTY AND ANY IMPLIED WARRANTIES OF MERCHANTABILITY, FITNESS FOR A PARTICULAR PURPOSE, AND NON-INFRINGEMENT OF ANY THIRD PARTY INTELLECTUAL PROPERTY RIGHTS. TI SHALL NOT BE LIABLE FOR AND SHALL NOT DEFEND OR INDEMNIFY DESIGNER AGAINST ANY CLAIM, INCLUDING BUT NOT LIMITED TO ANY INFRINGEMENT CLAIM THAT RELATES TO OR IS BASED ON ANY COMBINATION OF PRODUCTS EVEN IF DESCRIBED IN TI RESOURCES OR OTHERWISE. IN NO EVENT SHALL TI BE LIABLE FOR ANY ACTUAL, DIRECT, SPECIAL, COLLATERAL, INDIRECT, PUNITIVE, INCIDENTAL, CONSEQUENTIAL OR EXEMPLARY DAMAGES IN CONNECTION WITH OR ARISING OUT OF TI RESOURCES OR USE THEREOF, AND REGARDLESS OF WHETHER TI HAS BEEN ADVISED OF THE POSSIBILITY OF SUCH DAMAGES.

Unless TI has explicitly designated an individual product as meeting the requirements of a particular industry standard (e.g., ISO/TS 16949 and ISO 26262), TI is not responsible for any failure to meet such industry standard requirements.

Where TI specifically promotes products as facilitating functional safety or as compliant with industry functional safety standards, such products are intended to help enable customers to design and create their own applications that meet applicable functional safety standards and requirements. Using products in an application does not by itself establish any safety features in the application. Designers must ensure compliance with safety-related requirements and standards applicable to their applications. Designer may not use any TI products in life-critical medical equipment unless authorized officers of the parties have executed a special contract specifically governing such use. Life-critical medical equipment is medical equipment where failure of such equipment would cause serious bodily injury or death (e.g., life support, pacemakers, defibrillators, heart pumps, neurostimulators, and implantables). Such equipment includes, without limitation, all medical devices identified by the U.S. Food and Drug Administration as Class III devices and equivalent classifications outside the U.S.

TI may expressly designate certain products as completing a particular qualification (e.g., Q100, Military Grade, or Enhanced Product). Designers agree that it has the necessary expertise to select the product with the appropriate qualification designation for their applications and that proper product selection is at Designers' own risk. Designers are solely responsible for compliance with all legal and regulatory requirements in connection with such selection.

Designer will fully indemnify TI and its representatives against any damages, costs, losses, and/or liabilities arising out of Designer's non-compliance with the terms and provisions of this Notice.